



Dynamic Audio Solutions

K-LA-DSP Series

User's Manual

Contents

Safety precautions	02
Warranty	03
Appearance for K-LA-DSP series	05
Technical Features for K-LA-DSP series	11
Presets for K-LA-DSP series	12
Back panel control and function for K-LA-DSP series	13
Suspension process for K-LA-DSP series	15
Wire connection for K-LA-DSP series	16
Product Application Samples for K-LA-DSP series	20
Dimension of K-LA-DSP series	30
Specification for K-LA-DSP series	33
Trouble Shooting	34

Thank you for purchasing Audiocenter active line array speaker system with built-in DSP K-LA-DSP series (hereinafter referred to as "K-LA-DSP series"). They have integrated technologies of switch mode power supply, Massive big power Class D amplifier and DSP control, as well as speakers made of new materials to design a new set of active line array speaker system with DSP control.

Please finish reading the manual before usage, to make sure the best performance of K-LA-DSP series. Please keep the manual for reference in the future.

◆ **Safety precautions**

When you set up, install and use the K-LA-DSP series, please follow the following safety measures strictly:

- There can be danger in any step during hanging installation. Everyone should check whether there is any damage on all hardware devices and pay attention to personal safety.
- All purchasers of Audiocenter should be professional people qualified to conduct the work related to such equipments.
- We strongly suggest the users pay full attention to local rules, regulations and laws. Installers have the responsibility to make sure the speaker installations are subject to local rules, regulations, and laws.
- If any danger or defect is detected, measures should be taken immediately to correct it.
- In touring application, please choose the installation hardware and occasion that can sustain the weight of the equipments.
- Please do not try to hang speakers over the design standard.
- Please do not place the power cable near heating source. Do not over bend or damage the power cables. Do not place heavy things on it. Please do not place the cables that may be pressed or cause stumbling.
- Please do not place the speakers near equipments sensitive to magnet fields, such as CRT display, TV or data saving materials.
- Only the specified rated voltage should be used for this product. Please refer to the back panel of the product for the specified voltage.
- Only the supplied power cable or plug should be used. (If you need to use the product in a place different from the purchase place, please consult your local Audiocenter distributor.)
- Please make sure to connect to proper power socket with protection grounding connection.
- Wrong grounding may cause short circuits. The product inside does not include any component that can be repaired by users. In case of abnormal operation, please stop using immediately, and contact qualified Audiocenter maintenance worker to repair.
- Please do not use the product in the rain, or near water, or in humid environment, to avoid liquid spilling to any opening.
- When any of the following situations occurs, please cut the power immediately, and pull out the power plug from the socket, and ask qualified Audiocenter maintenance worker to repair.
 - This equipment be failed or damaged
 - Wear or damage of the power cable or plug.
 - Abnormal smell or smoking
 - Some substance falls into the product
 - Sound stops suddenly when using the product.

- Regularly check the power cord and plug.
 - When pulling out the power plug from the power socket or the product, please make sure to grab the plug instead of the power cable. Pulling the power cable directly may cause damage.
 - If the product is not used for long time, or there is thunder storm, please pull out the plug from the socket.
 - Please do not place the product in any uneven position. Otherwise, it may cause falling off suddenly.
 - If the product is not fixed safely, please do not place it in a position that may cause easy falling.
 - Please do not block the air hole Vents. The product has air hole Vents at the back to avoid internal temperature too high. Bad ventilation may cause damage to the product or even fire.
 - Please do not hang or install any other component to the handle of the speaker. It may cause damage or injure.
 - Please do not press the back panel of the product to the wall. Otherwise the plug may touch the wall and separate from the cable, and cause short circuits, malfunction, or even fire.
 - Before connecting the product to other equipment, please turn off the power switch of all equipments. Before turning on or off the power switch of all equipments, please turn down the volume to the minimum.
 - Please do not use the product in a very high or uncomfortable volume. Otherwise, it may cause permanent damage to your ear.
 - In case of sound distortion, please do not use the product. To continue using the product in such status may cause fire.
 - Using mobile phones near the speaker may cause noise. In case of noise, please use the mobile phone far from the speaker.
- If you need service, please contact Audiocenter service center, agent, or distributor in your area.

⚠ In order to avoid injury to you or others and loss on equipment or property, please make sure to follow above basic items.

◆ **Warranty**

We ensure all the Audiocenter products are high-quality and professional goods, no matter for the performance or for the craftwork..

Before delivery, each single piece of products is checked by us for outlook and also automatically tested by equipment for high standard sound quality, then QC passed.

Product warranty items and Guarantee (China Mainland only)

- Products warranty period is 3years (starting from the date buying the products). During warranty period, if any damage or fault in our goods, after Audiocenter technician verified the issue was not caused by wrong operation and usage or unexpected damage during the transportation, Audiocenter will repair the products and exchange the spare parts free of charge.
- Because of long distance for oversea transportation and other changeable factors, warranty 3 years is for China mainland only.
- If under below conditions, Audiocenter distributor and dealers will reserve the right to reject any repair.
 - a) Products were not bought from Audiocenter dealers or distributors, or it is fakery.
 - b) Factory serial number is invalid, damaged already, obliterated, removed or no any sale record.

- Under below-mentioned conditions, information in warranty card or website will be invalid.
 - a) The issue was caused by the intentionally wrong operation. Such as signal overload or impact with the signal feedback.
 - b) Problem or fault caused by wrong handling, incorrect operation, unexpected damage
 - c) The issue caused by inefficient outer conditions, such as oversize input voltage and huge humidity.
 - d) The damage caused by the accident or natural hazard.
 - e) Products were repaired by other people, not by Audiocenter technicians.
 - f) Installation of the products in the wrong way.
- Warranty and maintenance of the goods are only for Audiocenter service center or appointed distributors.
- If products damaged directly or indirectly due to the equipment defective, Audiocenter won't take any responsibility.
- If Audiocenter products are out of warranty period, reasonable fee will be charged for repair.
- Audiocenter reserve the right for explaining of above items. If any change, we will keep you informed. If any query, please contact us by phone: 0086-20-86767882 or visit our website: www.audiocenter.net.

Package accessories:

Power cable

User's manual

Quality Certificate

Please check above items carefully. If any questions, please advise Audiocenter representative, dealers, distributors, or contact by email box: support@ac-pro.net.

Optional accessories:

Frame for flying and ground stacking

Flightcase

Dolly

Coupling bar

Three boxes Horizontal sustain bracket

◆ **Appearance for K-LA-DSP series**

K-LA218-DSP



- 1. Speaker
- 2. Amplifier module
- 3. LOGO
- 4. Coupling bar Mounting hole
- 5. Grill
- 6. Rubber feet
- 7. Handle
- 8. wheelers
- 9. Front built-in locking Accessories
- 10. Back built-in locking Accessories
- 11. Power led

K-LA215S-DSP

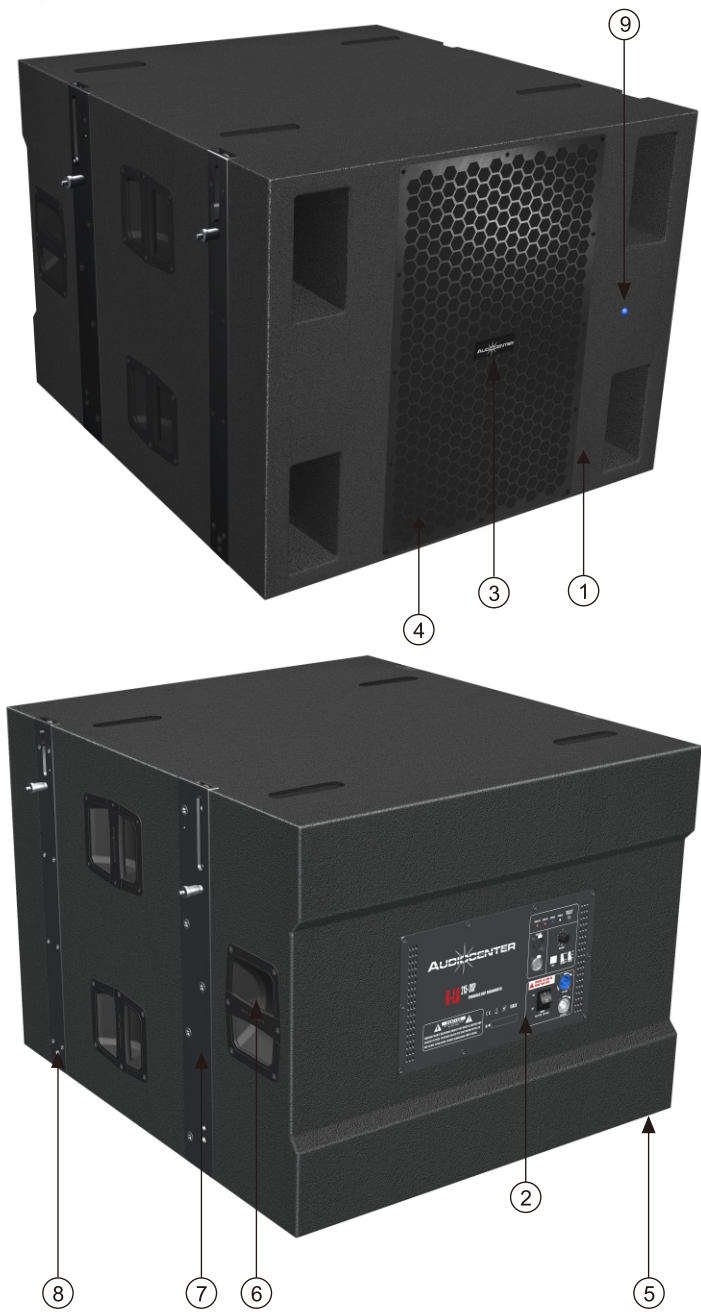

- 1. Speaker
- 2. Amplifier module
- 3. LOGO
- 4. Coupling
- 5. Rubber feet
- 6. Handle
- 7. Front built-in locking Accessories
- 8. Back built-in locking Accessories
- 9. Power led

K-LA118-DSP



- 1. Speaker
- 2. Amplifier module
- 3. LOGO
- 4. Guide hole
- 5. Rubber feet
- 6. Handle
- 7. Front built-in locking Accessories
- 8. Back built-in locking Accessories
- 9. Coupling bar Mounting hole
- 10. Power led

K-LA212-DSP

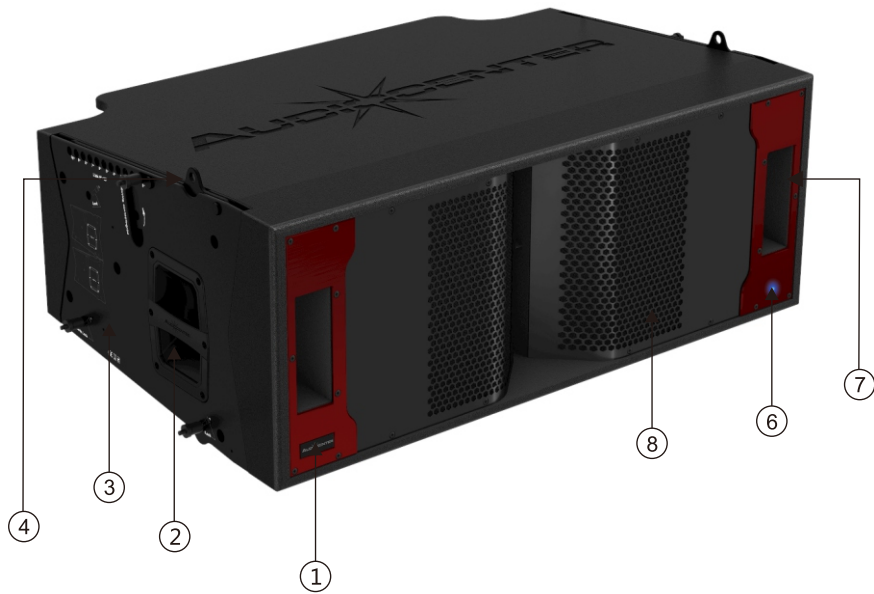

1. LOGO
2. Handle
3. Hanging pendant
4. Slider
5. Amplifier module
6. Power led
7. Guide hole
8. Grill & Horn

K-LA210-DSP



1. LOGO
2. Front Slider
3. Back Slider
4. Front built-in locking Accessories
5. Handle
6. Back built-in locking Accessories
7. Amplifier module
8. Phase plate & Horn
9. Guide hole
10. Power led

K-LA28-DSP



- 1. LOGO
- 2. Red horn
- 3. Front Slider
- 4. Back Slider
- 5. Front built-in locking Accessories
- 6. Handle
- 7. Back built-in locking Accessories
- 8. Amplifier module
- 9. Power led

◆ **K-LA-DSP Technical Features**



K-LA218-DSP



K-LA215S-DSP



K-LA118-DSP



K-LA212-DSP



K-LA210-DSP



K-LA28-DSP

● **Features:**

1. Integrated with massive big power, switch mode power supply technology and DSP control technology.
2. With built-in DSP control technology, all functions like EQ adjustment, phase correction, delay, limiter, etc, can be realized easily.
3. High efficiency Class D amplifier technology, light weight and more compact.
4. With 3 presets of K-LA-DSP Series, users can recall different presets for different applications to get the right sound performance.
5. Powerful protection function with built in DSP processing circuit that can give strong limiter protection to the HF and LF separately.
6. Advanced AD/DA converter. 96 KHz signal sampling frequency and 56-bit precision device to ensure the clear and clean sound.

◆ Presets for K-LA28/210-DSP

There are three presets in K-LA28/210-DSP for users to recall for usage in different applications.

1st Preset-Linear

2nd Preset-HFX(High Frequency Extension)

3rd Preset-W/SUB

Presets for K-LA-DSP series are set up by factory before shipment. Users can only recall the presets for usage in different applications, but can't change or delete the presets.

● 1st preset-Linear

This is the default preset in K-LA-DSP series when users operate K-LA-DSP for the first time or reset the preset. With this preset, the frequency response of the K-LA28-DSP between 80Hz-18 KHz is special linear response. The HF and LF are in a balance. It is the balance between high frequency and low frequency. With Equalizer or external DSP, users can simply adjust the frequency response of the speakers to satisfy some special application demand, such as defective architectural space acoustics, strange sound source or personal taste sound.

● 2nd Preset-HFX

This preset is based on Linear preset and fully considering the characteristics of outdoor amplification. High frequency attenuation is greater than the low frequency part outdoor in the process of sound transmission, It shows a high frequency of category. After 3 KHz, high frequency increases gradually as the increase of the frequency, This is always used to improve the high expression.

● 3rd Preset-W/SUB

This preset is made to match K-LA-DSP with subwoofer. To work together with subwoofers, K-LA-DSP can have much better sound dynamic. Audiocenter subwoofers or subwoofers of other brands are recommended to work with K-LA-DSP.

◆ Presets for K-LA212-DSP

There is only one default preset K-LA212-DSP.

◆ Presets for K-LA118/215S/218-DSP

To match with Audiocenter K-LA-DSP series or speaker systems of other brands, K-LA118/215S/218-DSP series are designed with 3 different kinds of presets: 80Hz,100Hz and 120Hz.

◆ The polarity of K-LA118/215S/218-DSP

Polarity, also called as phase sometimes, means that the input voltage is positive or negative in specific time. In most cases, the positive will drive the diaphragm of the speaker to move forward, and the negative will drive it backward. When a specific frequency signal or similar signal repeats, the polarity must be the pull same, so that the input efficiency will be the highest. For subwoofer system, this is very important. Wrong connection or usage will change the polarity, and lower the system's efficiency.

K-LA118/215S/218-DSP polarity can be changed according to different using conditions.

When full range speakers system and subwoofer speaker system are combined, please change the phase according to their distance to get the best sound performance.

◆ **K-LA-DSP back panel control and function**

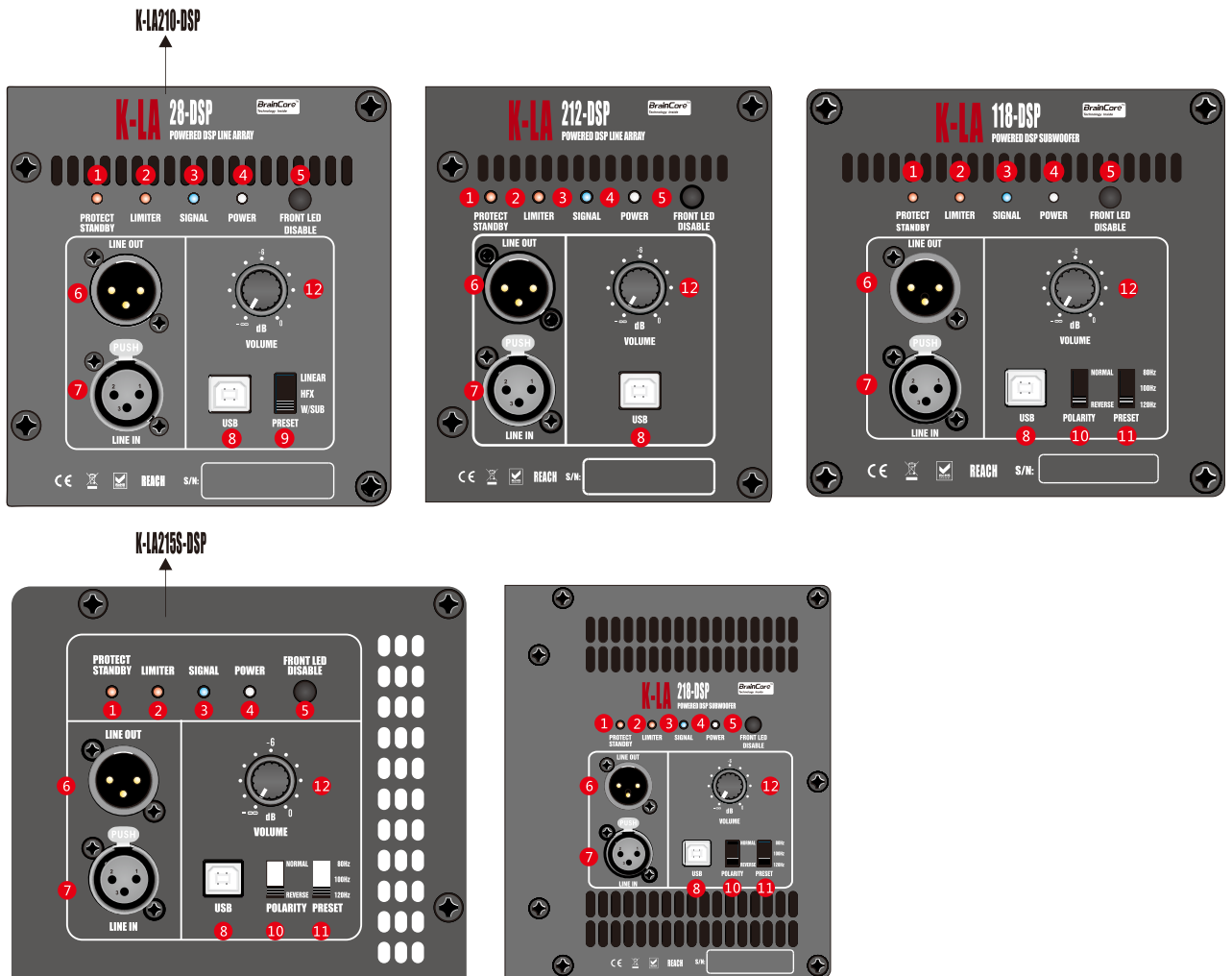

- 1 Protect Indicator**
 When the protection system is activated, the LED is on. The protection system will operate in the following situations:
 The amplifier over heated;
 DC output;
 Overload Current;
 Power activation voltage too high or too low;
 The amplifier in stand-by mode;
- 2 Limiter indicator**
 When output limiter is activated, the LED is turned on. If the output voltage of the amplifier is over the maximum value, the output limiter will operate to damp the output signal of amplifier.
- 3 Signal indicator**
 When detecting Line channel has input signal, the LED is on.
- 4 Power indicator**
 When speaker connected to power, the LED is on.
- 5 Push the button, the front LED will be off**
 This setting is recommended when the front LED light is too blinding.
 Balance the button, the front LED will be on (working: Blue light; standby: red light).
- 6 OUTPUTS Socket (LINE OUT)**

Balanced XLR (Male), Parallel to (LINE IN), the signal in LINE OUT is equivalent with the signal in LINE IN. And the signal in LINE OUT XLR will without influence when set up the volume for speaker.

7 Inputs socket (LINE IN)

Balanced XLR (Female), can provide frequency signal input.

8 USB terminal

Debug by factory (it is not open to the user).

9 Presets for K-LA-DSP series

There are 3 presets in K-LA28/210-DSP speakers for users to recall for usage in different applications.

10 The polarity of K-LA-DSP series:

Polarity, also called as phase sometimes, means that the input voltage is positive or negative in specific time. In most cases, the positive will drive the diaphragm of the speaker to move forward, and the negative will pull it backward. When a specific frequency signal or similar signal repeats, the polarity must be the same, so that the input efficiency will be the highest. For subwoofer system, this is very important. Wrong connection or usage will change the polarity, and lower the system's efficiency.

K-LA-DSP series polarity can be changed according to different using conditions.

When full range speakers system and subwoofer speaker system are combined, please change the phase according to their distance to get the best sound performance.

11 Preset

To match with Audiocenter system or third party 2-way speaker systems, K-LA218-DSP series are designed with 3 different kinds of presets:80Hz,100Hz and 120Hz.

12 Volume Control

Use the VOLUME (sound volume) Knob to control the Gain of input signal in the line input connector (7). This volume control can adjust the sensitivity, so that can control and end the signal from amplifier to loudspeaker.

◆ Suspending the K-LA-DSP series Loudspeakers

 **WARNING!** Read and follow these instructions carefully. If the loudspeakers are not suspended properly, they could fall causing personal injury and damage to the equipment.

Rules for Suspension

- Consult a professional mechanical or structural engineer licensed in the jurisdiction of the sound system installation, to review, verify, and approve all attachments to the building or structure.
- Employ the services of a certified, professional rigger for hoisting, positioning and attaching the equipment to the supporting structure.
- Correct use of all suspension hardware and components is imperative in sound system suspension and deployment.
- Always calculate suspended loads before lifting to make sure suspension components and hardware are used within their respective load limits.
- Consult local codes and regulations to fully understand the requirements for suspended loads in the venue in which you will suspend the equipment.
- Use only the K-LA-DSP series Array Frame for suspending the array.
- Be absolutely certain of the integrity of any structural member intended to support suspended loads. Hidden structural members can have hidden structural weakness.
- Before lifting, always inspect all components (pins, suspension brackets, bolts, nuts, fly belt, stainless steel shackle etc.) for cracks, wear, deformation, corrosion, missing, loose, or damaged parts that could reduce the strength of the assembly. Discard any worn, defective, or suspect parts and replace them with new appropriately load-rated parts.

When a load is either moved or stopped, its static weight is magnified. Sudden movements can magnify the static weight several times. This magnification of static weight is called “shock loading”. Shock loading poses a danger to equipment and workers. The effects of shock loading can be instantaneous, or may remain undetected unless the equipment is visually damaged. Proper preparation for shock loading requires careful planning and knowledge of equipment, suspension, and lifting practices. Shock loading of equipment and structures is usually confined to lifting and installation, but natural forces (winds, earthquakes, and so on) can impose shock loads several times the static load. Because of this, structures and suspension equipment must be capable of supporting several times the weight of the suspended equipment.

Maximum Suspended Load

The K-LA-DSP components are safe engineered design.

The mechanical parts for K-LA-DSP array system all use the finest stainless steel, completely consider of the safety. One side of array system can maximum set up 16pcs of K-LA-DSP loudspeakers and this is make sure safe when use (Any questions, please contact the service centre or agency or dealer of Audiocenter at your area)

◆ **Cable Connections**

Making Audio connections

Figure 1 (Connection for balanced inputs), Figure 2 (Connection for unbalanced inputs)
 The soldering/welding way to connect the frequency patch cable:

Balanced inputs:

Connect to the plug as shown.

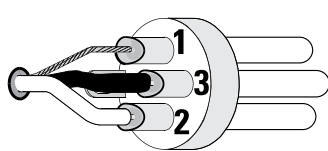

1=shield (ground)

3=negative (-)

2=positive (+)

1-1

Unbalanced Inputs:

Connect to the plug as shown

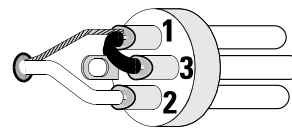

1=shield (ground)

3=jumper to pin 1

2=positive (+)

1-2

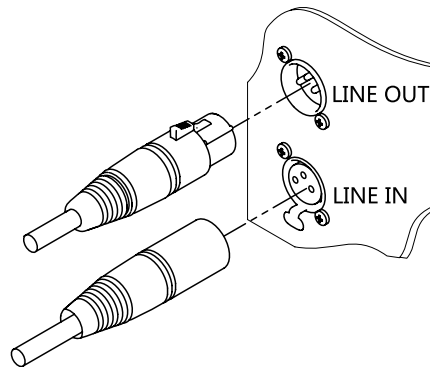

1-3

The loop-thru cables supplied in the package are designed for use in the array (Figure 3)

1. Connect the audio source (male XLR plug) to the LINE IN female XLR connector on the amplifier.
2. If you are using the audio loop-thru connections, connect the female end of an XLR Audio Loop-thru Cable (supplied) to the LINE OUT connector on the first amplifier in the loop-thru chain.
3. Connect the male end of the XLR Audio Loop-thru Cable to the LINE IN of the next loudspeaker amplifier in the loop-thru chain.
4. Continue this process until all the audio connections for the loudspeakers in the array are made.

System Power

For safety reasons, it is important to follow the proper power connection and disconnection sequence as addressed in this section.

Proper power on/off sequencing can help to prevent unexpected sounds from being produced by the system (pops, clicks, thumps). These sounds are unpleasant and can take away from the overall professionalism of the presentation. Always follow the rule that loudspeakers are “last on, first off”.



NOTE: The K-LA28-DSP, K-LA210/215S/218-DSP employs a universal power supply, capable of operating the system with input AC power voltages ranging from 100-130VAC(60Hz), 220-240VAC(50/60Hz). Use only the power cable that is correct for your location.

Connect Loop-thru Power Cables

K-LA28-DSP, K-LA210-DSP features a loop-thru power connector system. Using four powerCON[®] Loop-thru cables, and one AC powerCON[®] Power Cord, you can power up to a maximum of five KLA loudspeakers on a single 16 amp/120V (8amp/240V) electrical circuit. The loop-thru connectors are color coded (blue = AC IN / white = AC LINK) and keyed differently to make sure the connections are correct.



WARNING!: The amplifier POWER switches do not remove AC mains power from the loop-thru cables. If the AC mains is connected to one K-LA28-DSP, K-LA210-DSP, electrical power is present on all connected loop-thru cables.

1. Make sure that all AC POWER (POWER) are off.
2. Make sure that the AC mains power cord is not connected. AC mains is the last power connection in the sequence.



WARNING!: Do not connect more than five K-LA-DSP Series loudspeakers together using the loop-thru power cables (four loop-thru cables, one AC power cord). If you are using loop-thru power cables, make all loop-thru connections prior to connecting to the AC mains.

3. Insert the white powerCON[®] connector, on the loop-thru cable, fully into the white AC LINK connector on them amplifier.
4. Twist the powerCON[®] connector clockwise until it locks in place.
5. Insert the blue powerCON[®] connector fully into the blue AC IN connector on the next amplifier to be powered.
6. Twist the powerCON[®] connector clockwise until it locks in place.
7. Repeat until all of the loudspeakers (up to five loudspeakers, using four loop-thru cables) in the array are properly connected.
8. Insert the blue powerCON[®] connector, on the AC power cord, fully into the blue AC IN connector on the first amplifier in the chain.
9. Twist the powerCON[®] cable connector clockwise until it locks in place.
10. Plug the other end of the power cable into the appropriate AC mains power source.
11. You may now turn on the AC power switch(es) using the Power-On procedure in this document.

Power-on Sequence

1. Bring the output level control of the mixer (or other audio source) feeding your loudspeakers to its minimum position.
2. Turn on all source devices (CD players, mixers, instruments).
3. Push on the power switch (POWER) up to “1” to apply AC mains power to the first powered loudspeaker in the signal chain.
4. When the amplifier is turned on, the white POWER indicator LED/the blue SIGNAL Indicator LED/the red LIMIT indicator LED, and the red PROTECT indicator LED on the amplifier panel, illuminate. After a few seconds the red PROTECT indicator, the blue SIGNAL and the red LIMIT indicator go out, and the white POWER indicator LED illuminates.
5. Turn on the remainder of the K-LA28-DSP, K-LA210-DSP loudspeakers in the order in which they receive audio signal first to last.
6. The level controls on your mixer may now be brought up.

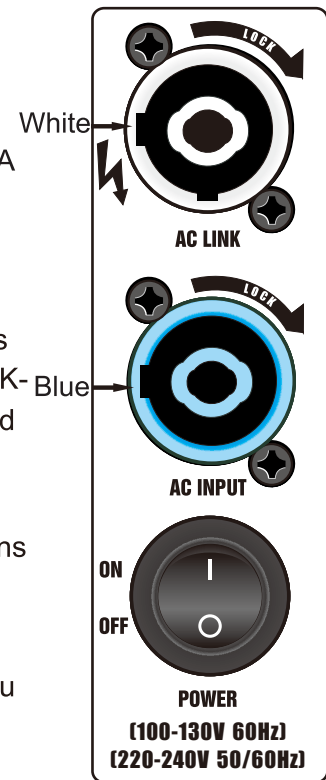

Power-off Sequence

1. Bring the output level control of the mixer (or other audio source) feeding your loudspeakers to its minimum position.
2. Turn the power switch (POWER) down to “0”, turn off K-LA28-DSP、 K-LA210-DSP, starting with the last loudspeaker in the signal chain.
3. Turn off the remainder of the K-LA28-DSP、 K-LA210-DSP loudspeakers in reverse of the order in which they receive audio signal-last to first
4. Turn off all source devices.

Disconnect AC Mains

1. Use the “Power-off Sequence” procedure and turn the AC power switches to the off position.
2. Unplug the power cable from the AC mains.
3. Disconnect all AC loop-thru cables by grasping the powerCON[®] cable connector, sliding the latch button away from the amplifier, twisting the powerCON[®] connector counterclockwise, and pulling straight out from the amplifier.
4. Remove the AC power cord by grasping the powerCON[®] cable connector, pressing down on the latch button, twisting the cable connector counterclockwise, and pulling straight out from the powerCON[®] chassis connector.

Standby Feature

All K-LA-DSP Series loudspeakers are equipped with an automatic standby feature to conserve energy when not in use.

If either no audio signal is present at the input of a K-LA-DSP Series system for 15 minutes, the unit goes into STANDBY, and the working station indicator in front of Speaker will from blue (operational mode) to red (standby).

When the equipment are in STANDBY, if there is audio signal, the working station indicator in front of Speaker will from red (standby) to blue (operational mode).

When the amplifiers are in STANDBY, a small amount of current continues to flow, keeping the amplifiers awake. The time it takes to come out of STANDBY to the full operational mode takes about 2 seconds, producing no audible effect.

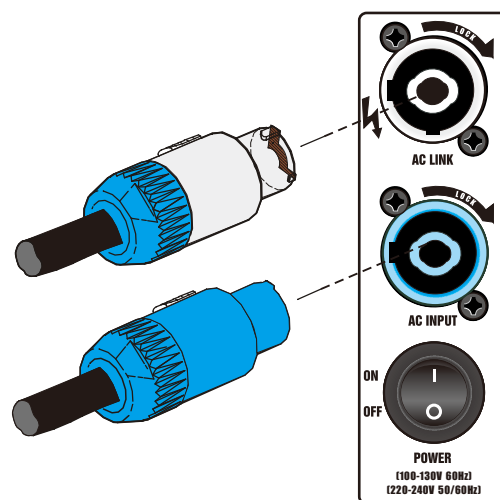

◆ K-LA-DSP Application Examples



Notice 1: Before hanging up the line array, please make sure the loading capacity. The speaker assembly and hardware can not be overloaded. The maximum combination of the line array should be no more than 16PCS.

Notice 2: Make sure the speakers in the line array are aligned, otherwise, it means the pins are not well connected and it will make the speakers detach and thus cause damage of the assembly or injury to people.

Notice 3: While hanging up the line array, the speakers and assembly of it should be well-supported.

Notice 4: Under all circumstance, the connection between hanging frame and speakers or assembly should start from under part to the upper section.

● **Connection between speaker assembly and hanging frame:**

Before hanging up, the front and back connecting poles of K-LA-DSP are locked. Please see the example: when rotating the assembly on the speaker upward, you should make sure the back connecting pole is aligning with the pole on the hanging frame, and then lock it with the pin.

Repeat the above process until all the speakers needed are firmly locked. After that, the line array is ready and you can hang it up.

Notice: Please make sure the speaker assembling pin are firmly locked with the hanging frame. Otherwise, if they didn't lock correctly, the speakers would probably detach and cause damaged to the speakers and injury to people.

● **Hanging of the line array :**

Notice 1: Before hanging up the line array, please consult professional construction or mechanical engineers with installation license, asking them to check, test or approve all the additional equipments on the building or construction. And you should ask the licensed professional assembling staffs to locate, hang up the line array to corresponding places.

● **Dispatching of the line array:**

Before dispatching the line array, please correctly prop up both side of it so as to lighten the stress that the heavy speakers had to its locking device, and thus separate the speakers from each other. Move down the front and back connecting pole and place it back to the speakers, and then lock it up with the pin. Please proceed the same process on the other side of the line array. Thus, all the speakers and assembly will be dispatched.

When connecting flying belt, shackle with the hanging frame, the different hole you connected to will engender different sloping angel of the line array.

◆ **K-LA-DSP Application Examples**

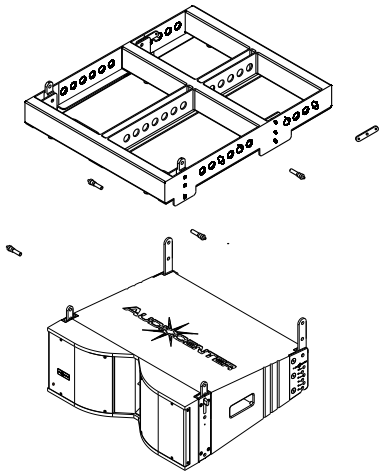

K-LA28-DSP

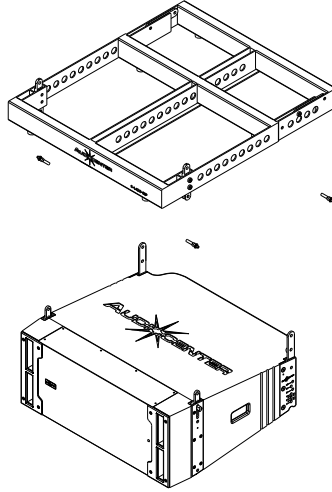

K-LA210-DSP

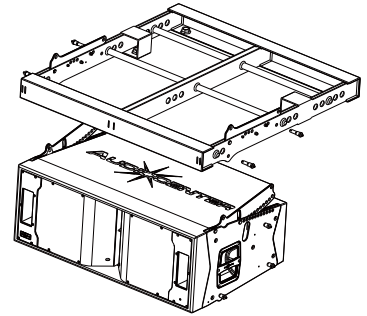

K-LA212-DSP

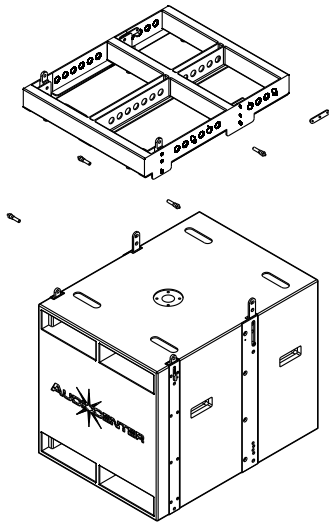

K-LA118-DSP

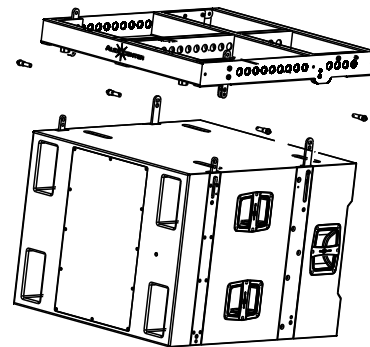

K-LA215S-DSP

Hanging frame of K-LA-DSP(material: steel; surface treatment: sandy black (white optional)).

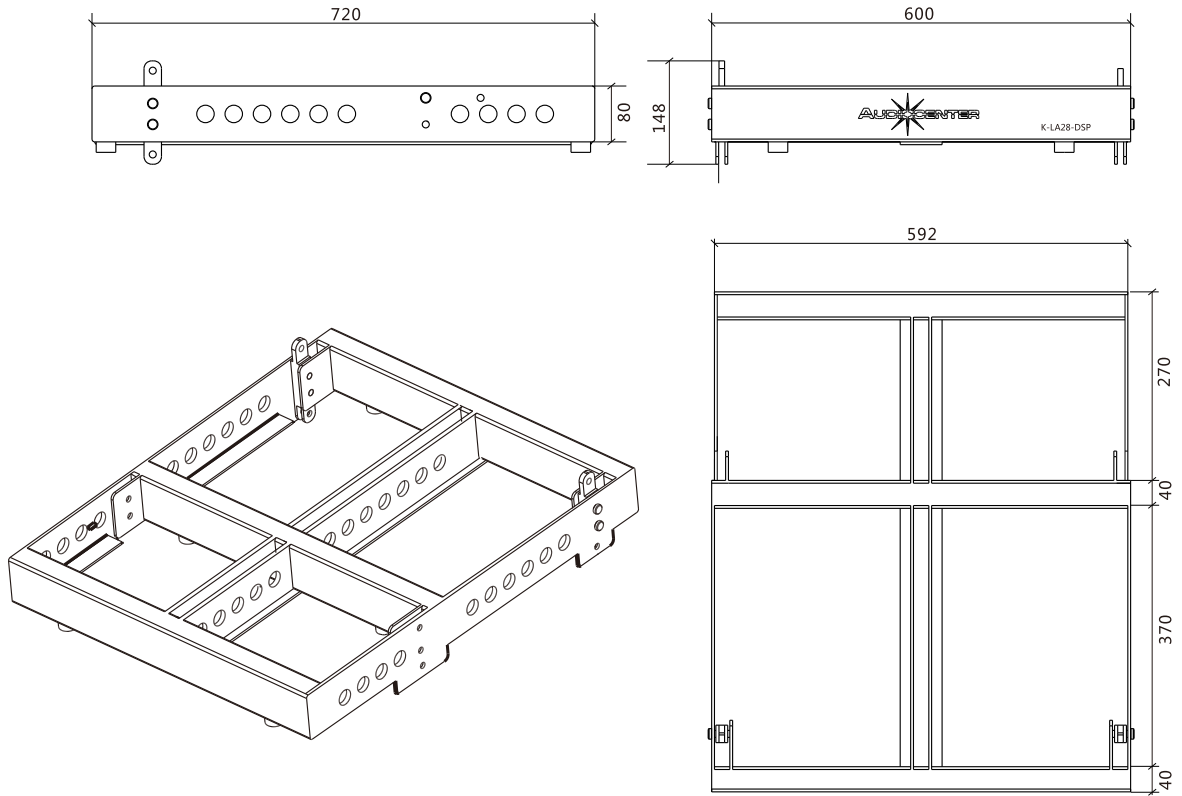

K-LA28-DSP/K-LA118-DSP

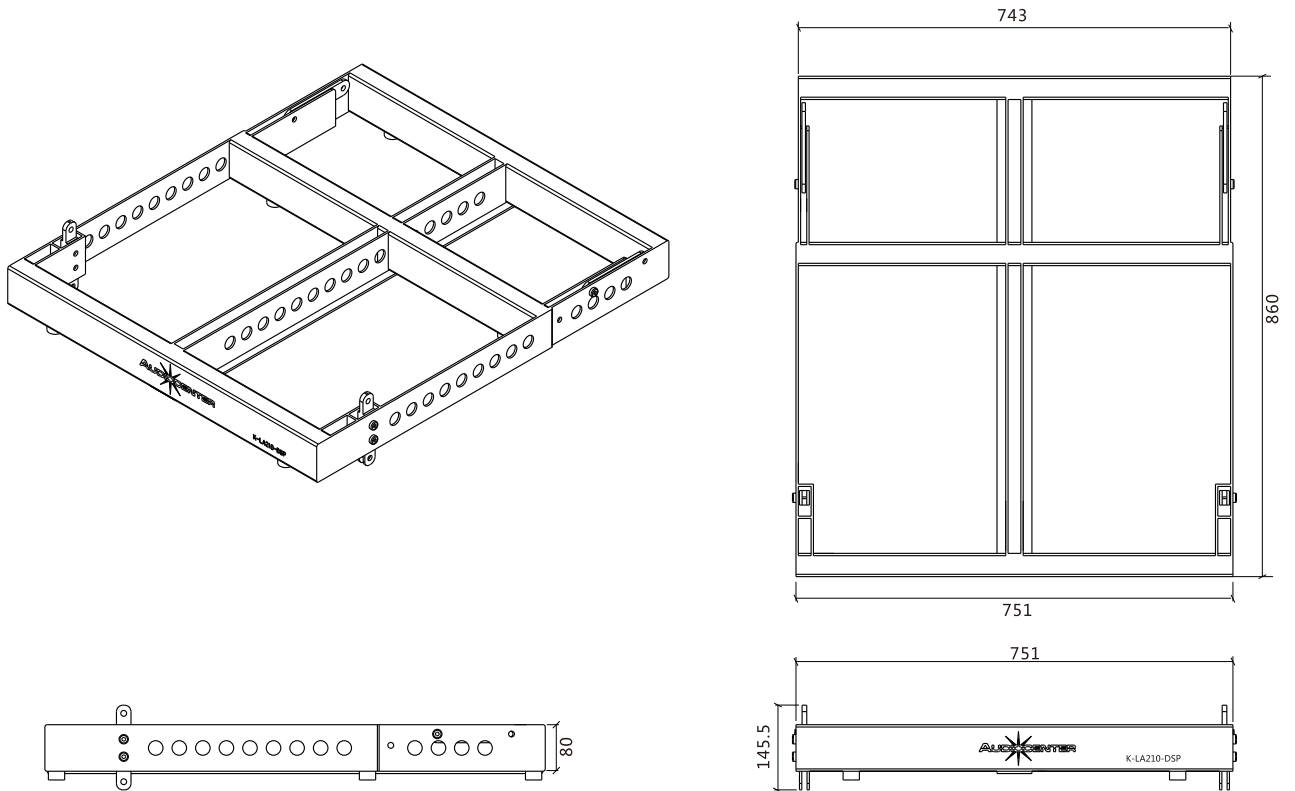

K-LA210-DSP/K-LA215S-DSP

Hanging frame of K-LA-DSP(material: steel; surface treatment: sandy black (white optional)).

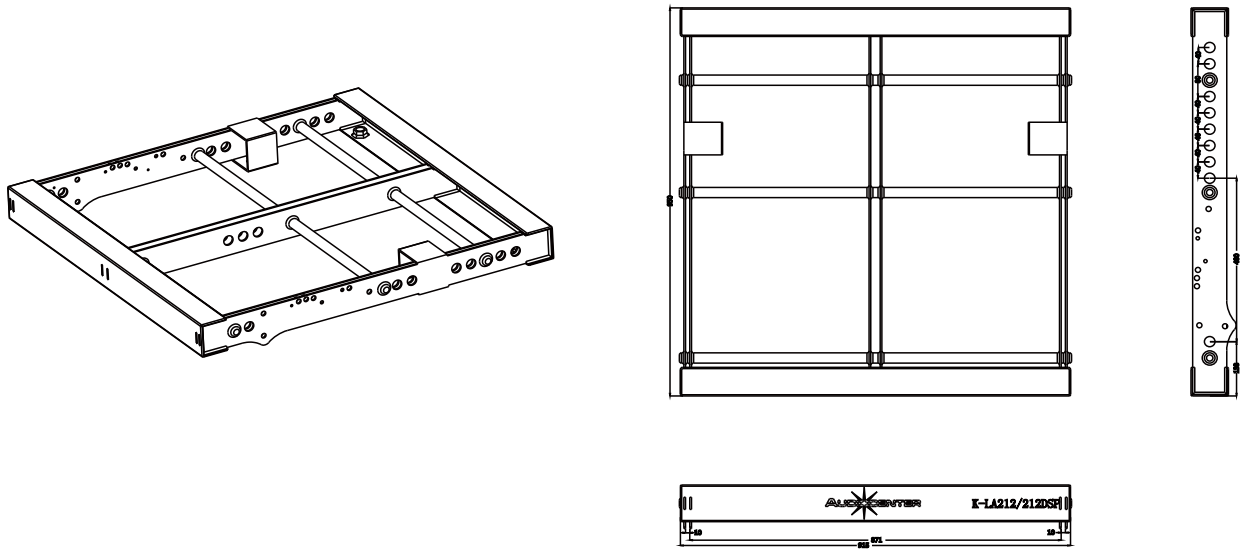

K-LA212-DSP

1. Stacking Guidance

Typical application sees below:

Notice: Please stack the system on even ground, otherwise it will lose its center of gravity and fall down, thus causing damage of the system or injury of people.

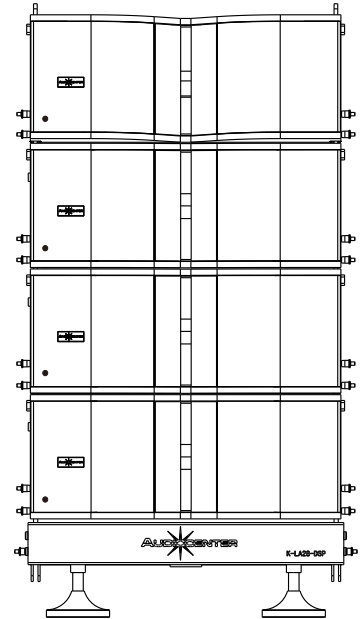
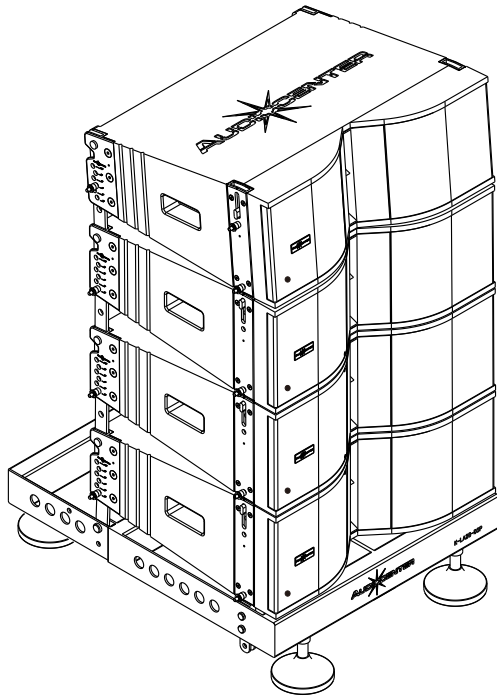

K-LA28-DSP

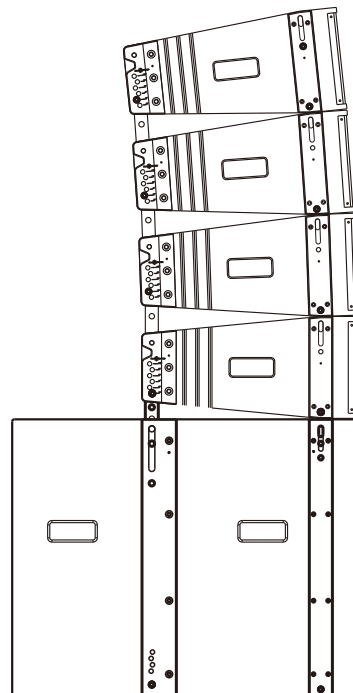
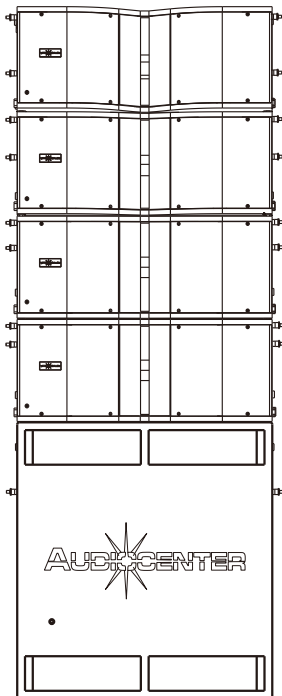

K-LA118-DSP+K-LA28-DSP

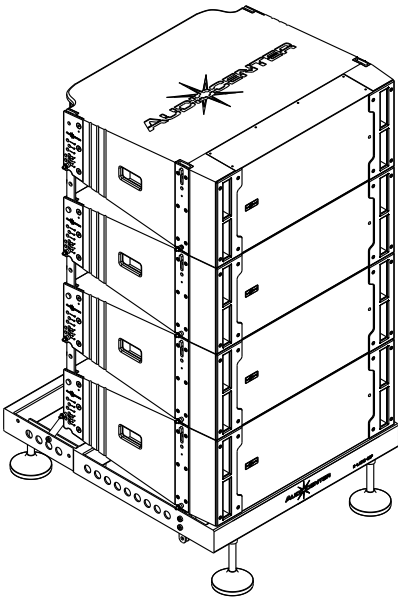

K-LA210-DSP

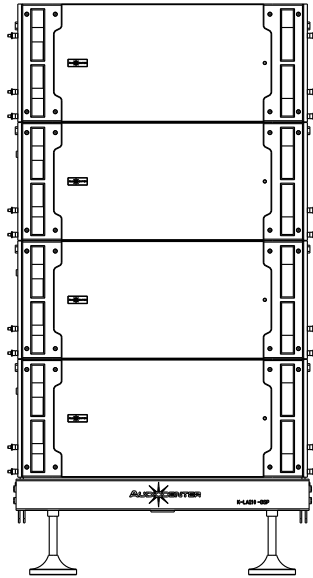

K-LA215^S-DSP+K-LA210-DSP

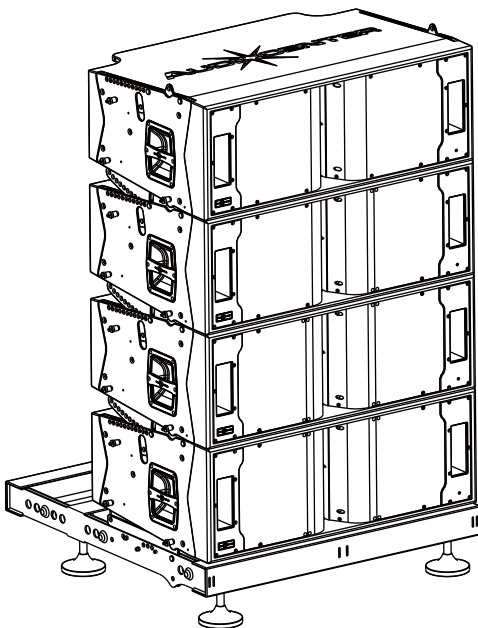
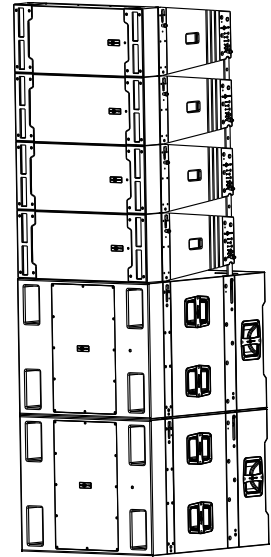

K-LA212-DSP

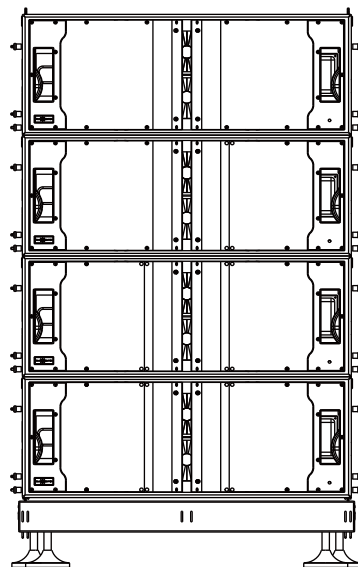

2. Flying Guidance
Typical application sees below.

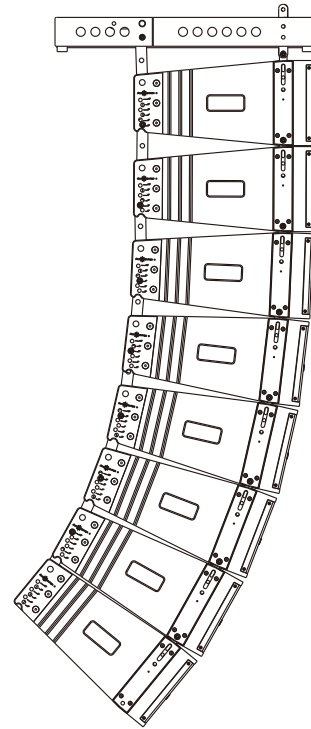
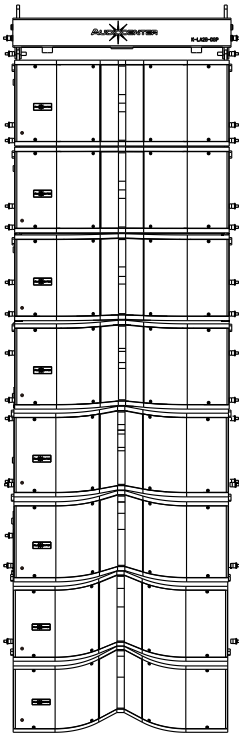

K-LA28-DSP

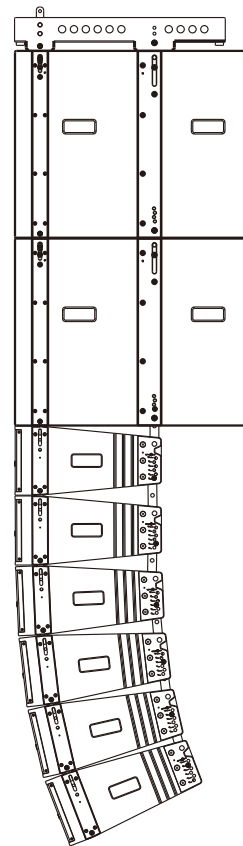
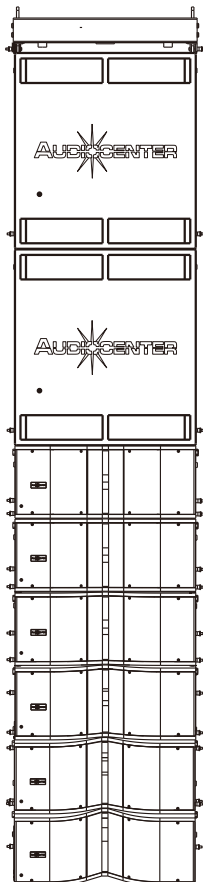

K-LA118-DSP+K-LA28-DSP

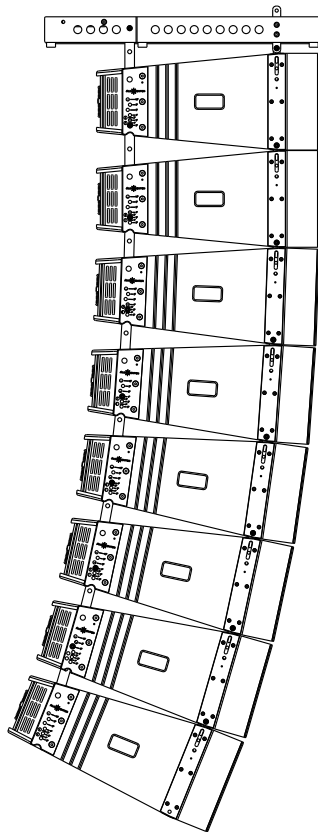
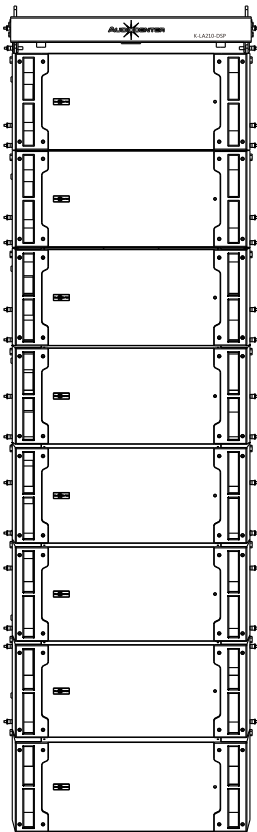

K-LA210-DSP

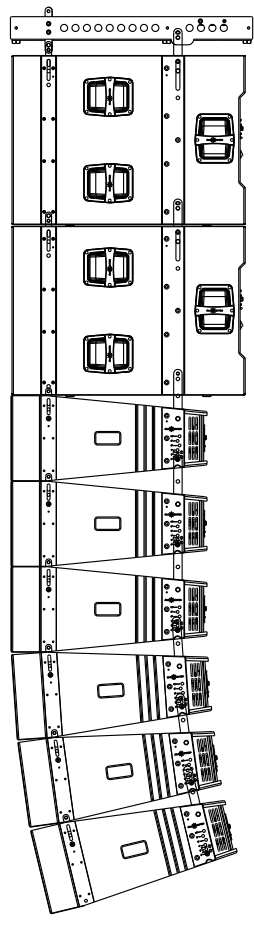
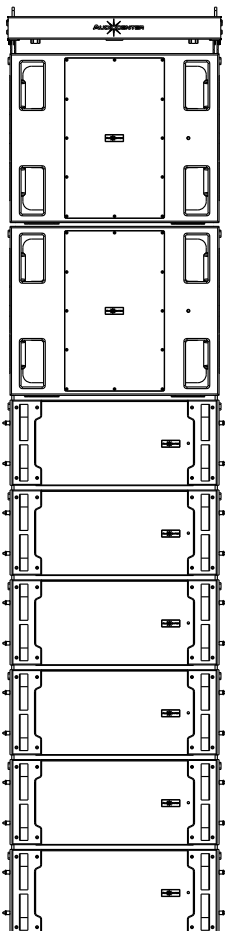

K-LA215S-DSP+K-LA210-DSP

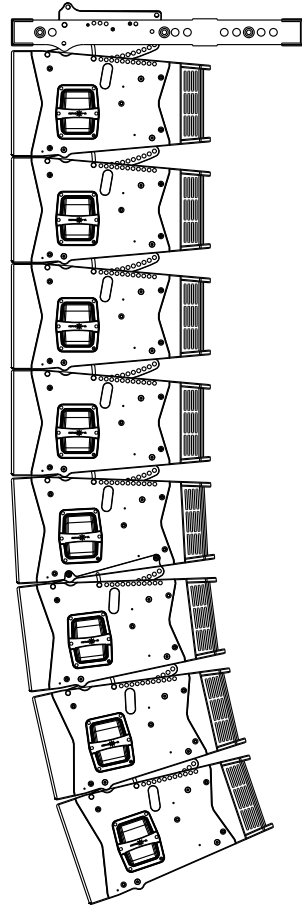
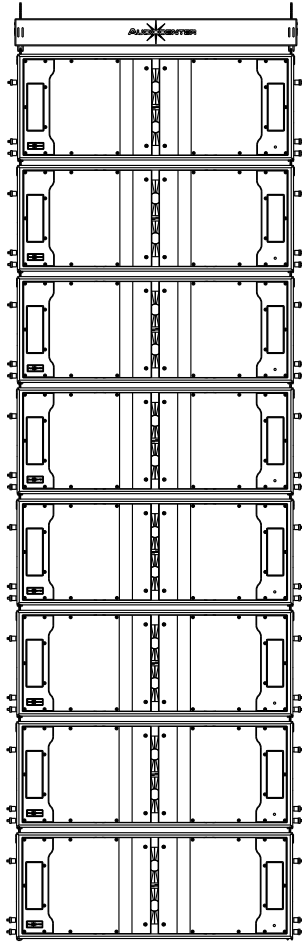

K-LA212-DSP

3. Sustain Guidance:

Notice1: The three-foot sustain frame and coupling bar must meet the safety regulation standards of loudspeaker.

Notice2: The speakers installed on the three-foot sustain frame or coupling bar should be no more than three pieces.

See examples as follow:

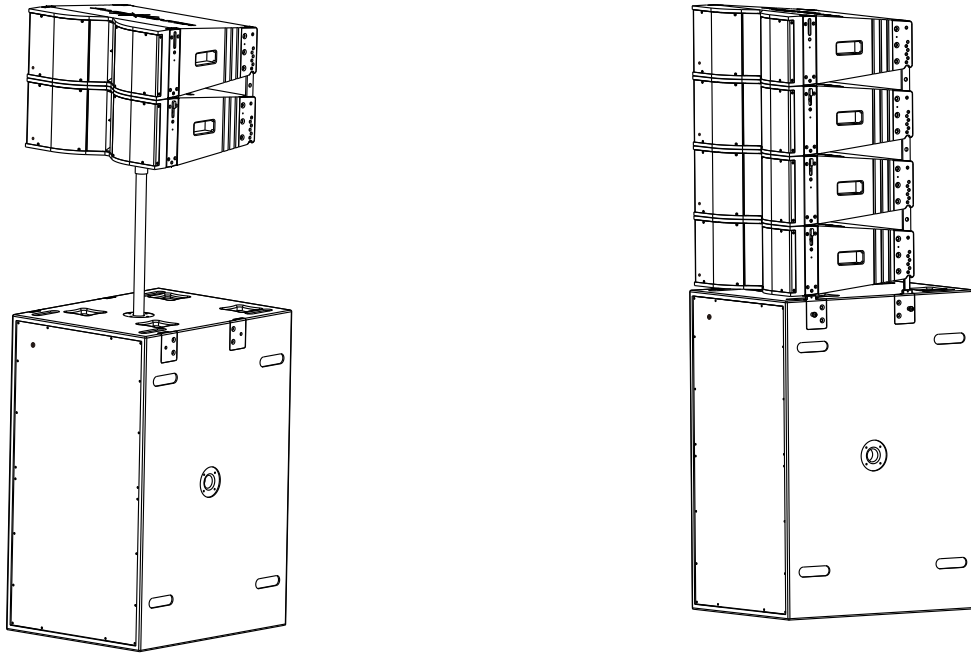

K-LA218-DSP / K-LA28-DSP

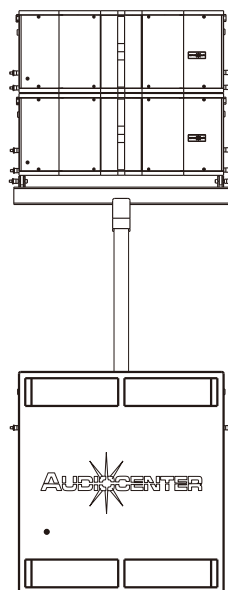

K-LA118-DSP+K-LA28-DSP

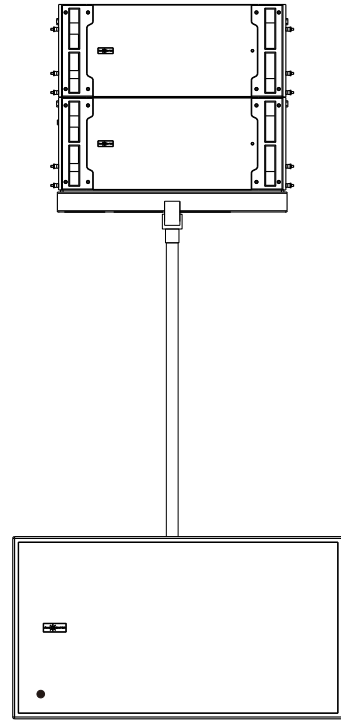
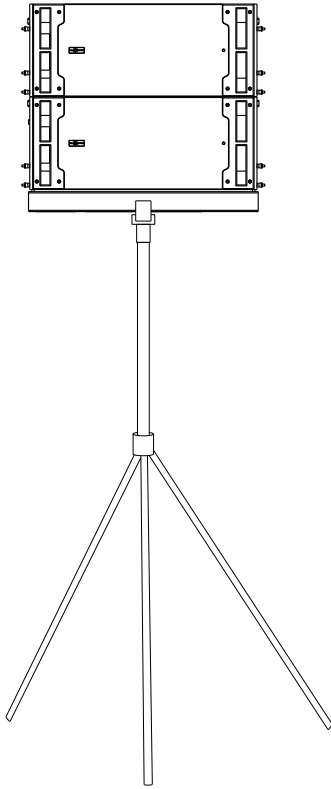

K-LA210-DSP

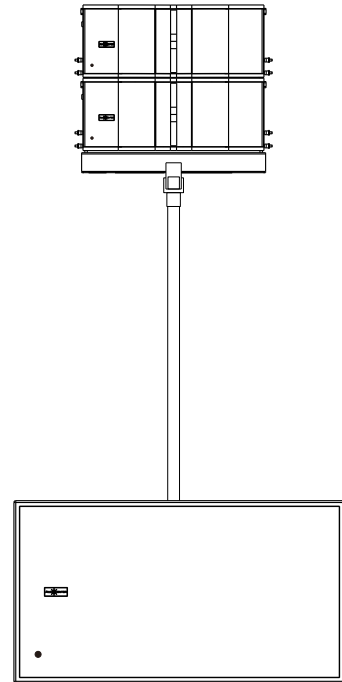
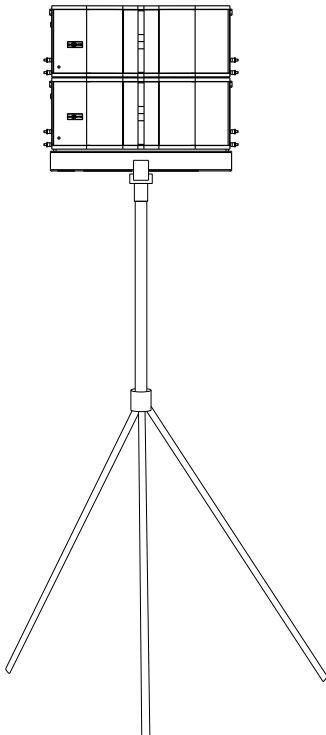

K-LA28-DSP

◆ **K-LA-DSP Series Dimension:**

K-LA218-DSP

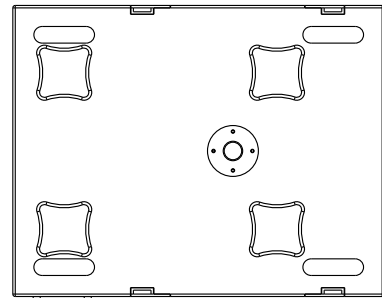
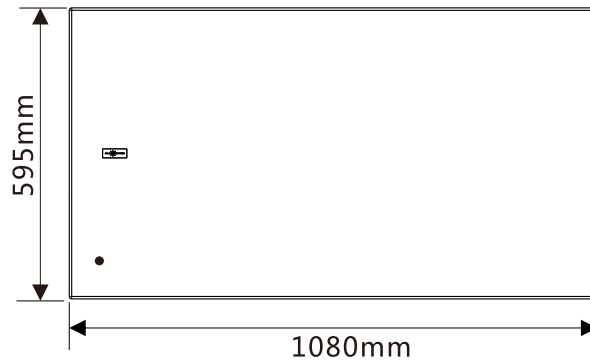
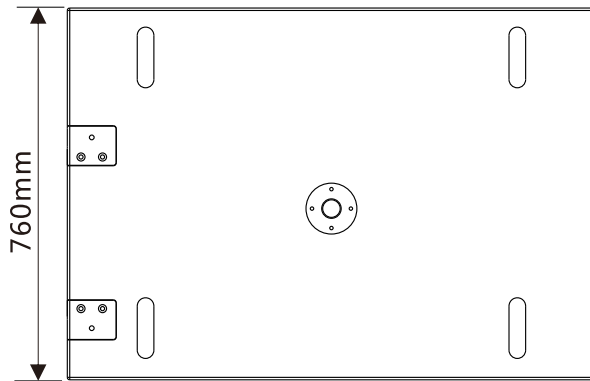

K-LA215S-DSP

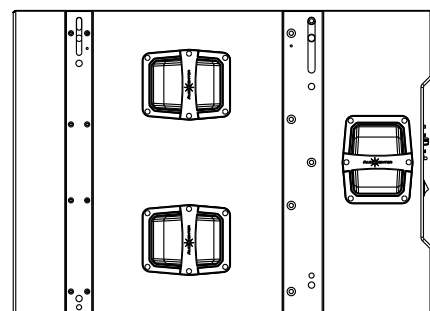
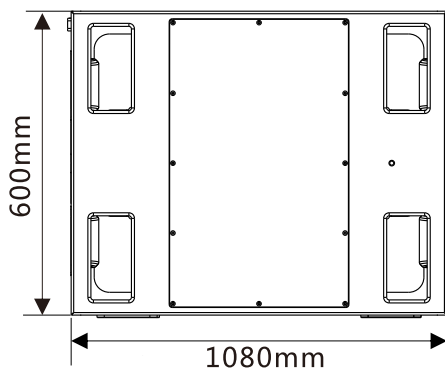
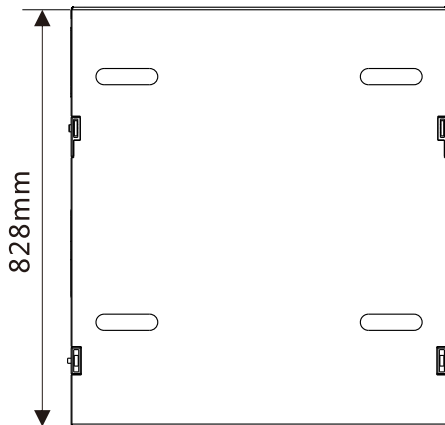

K-LA118-DSP

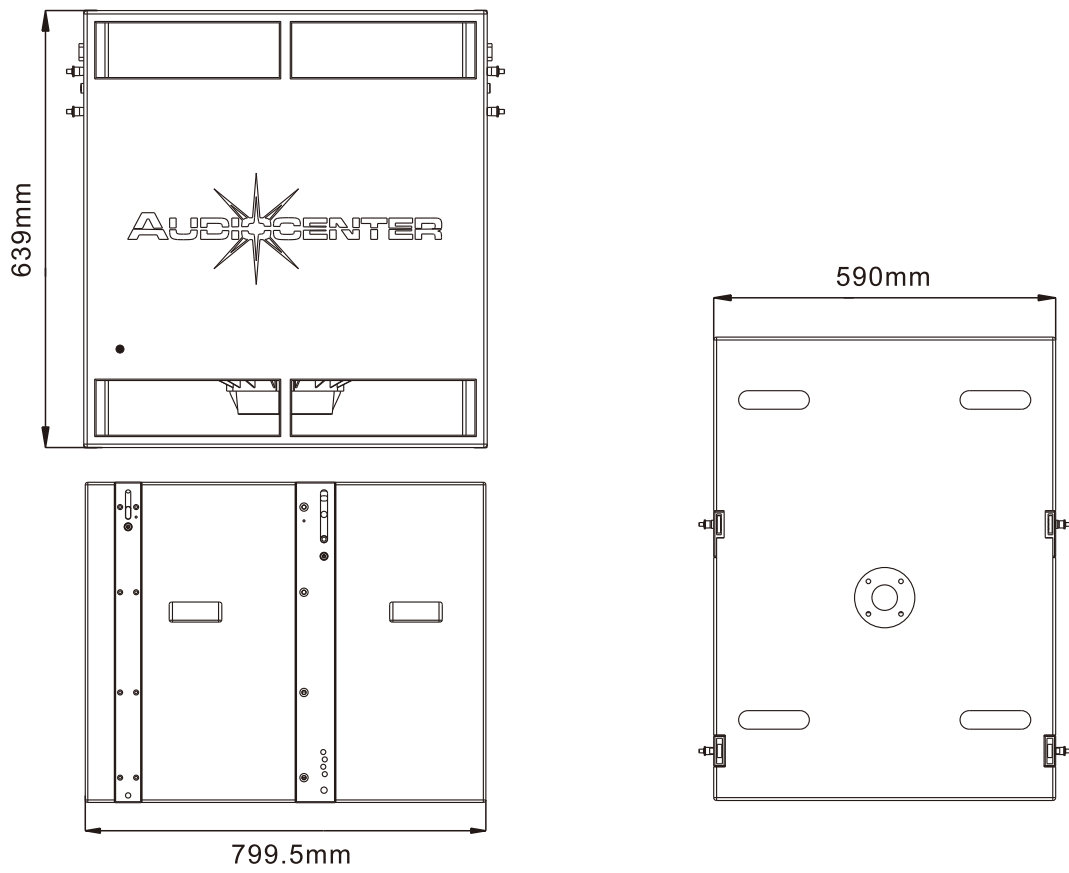

K-LA212-DSP

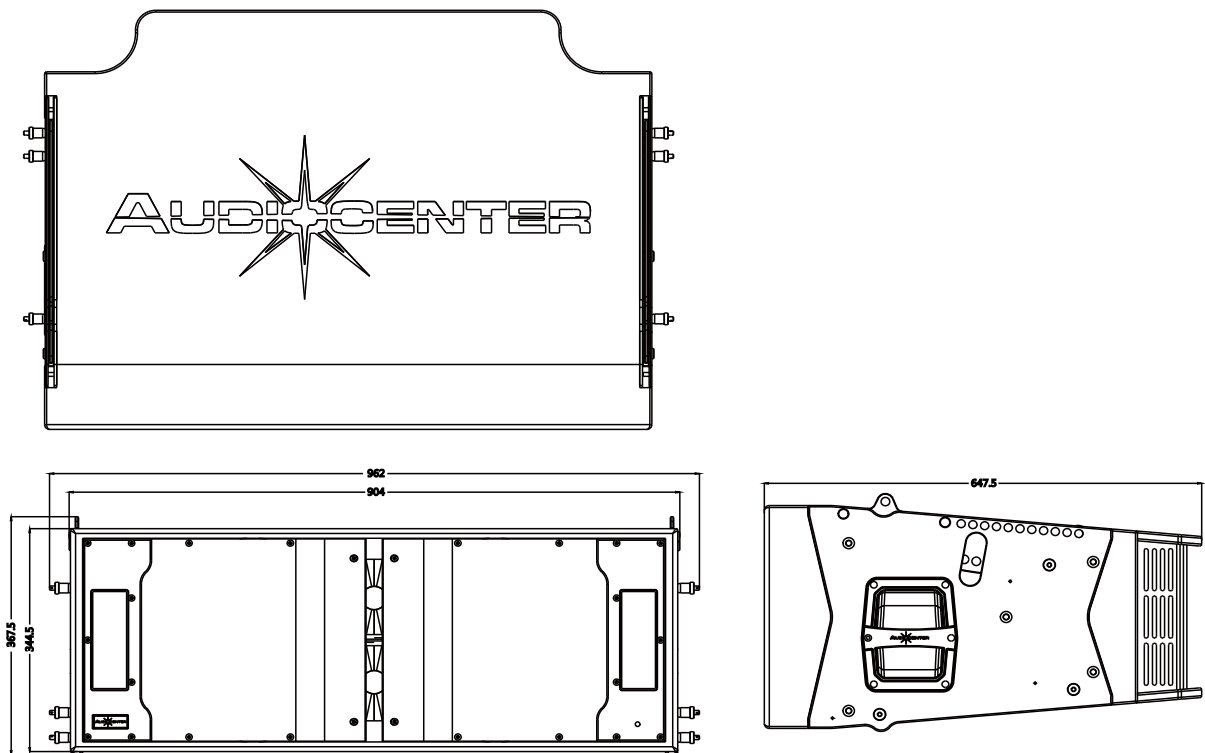

K-LA210-DSP

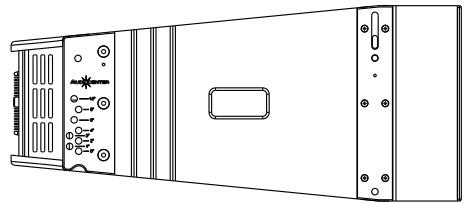
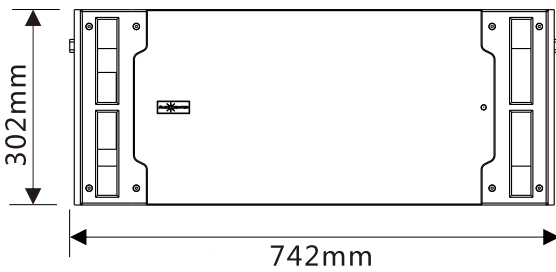
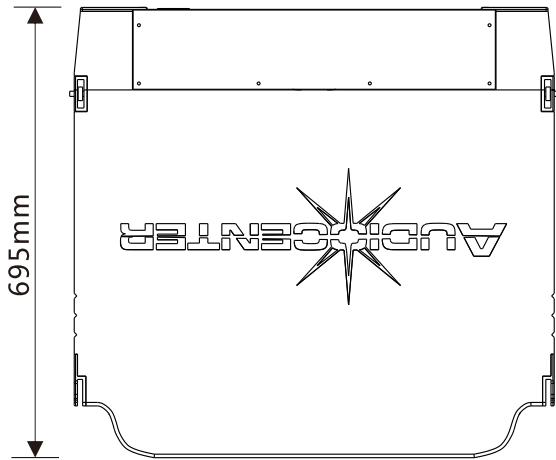

K-LA28-DSP

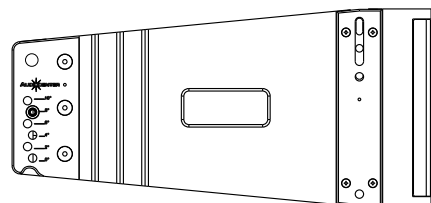
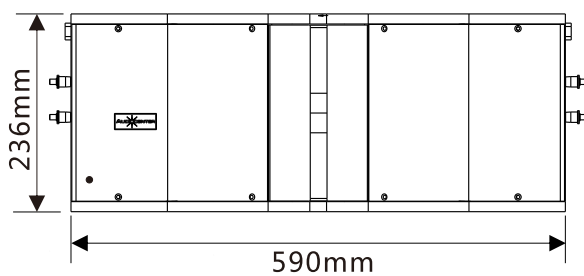
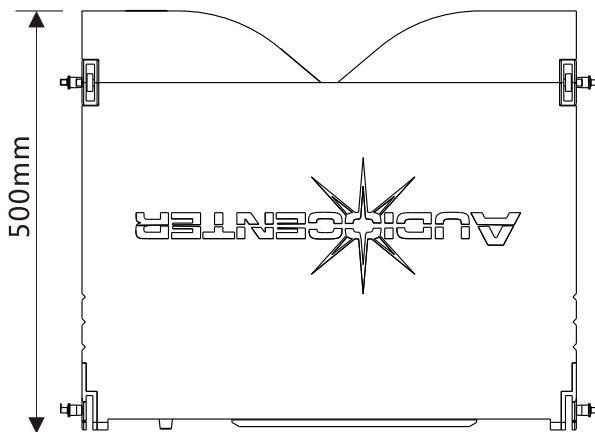

◆ K-LA-DSP Series Technical Specification

SPECIFICATIONS		K-LA28-DSP	K-LA210-DSP	K-LA212-DSP	K-LA118-DSP	K-LA215S-DSP	K-LA218-DSP	
Frequency Response (-6dB anechoic chamber)		60Hz-20KHz	57Hz-20KHz	55Hz-20KHz	32Hz-150Hz	35Hz-300Hz	32Hz-150Hz	
Horizontal Coverage Angle (Symmetrical)		100°			90° (K-LA212-DSP90) 60° (K-LA212-DSP60)			
Vertical Coverage Angle (Symmetrical)		Depend on the amount of the speaker and curvature of the line array					/	
Maximum Calculated SPL/1M	Continuous	122dB	127dB	129dB	131dB	132dB	134dB	
	Program	125dB	130dB	132dB	134dB	135dB	137dB	
	Peak	128dB	133dB	135dB	137dB	138dB	140dB	
Driver	HF	Customized BEYMA ferrite driver, 1.75" voice coil, 1" exit	Customized BEYMA ferrite driver, 2.84" voice coil, 1.4" exit	Customized BEYMA Neodymium driver, 2.84" voice coil, 1.4" exit	/			
	MF	Customized BEYMA ferrite driver, 2" voice coil	Customized BEYMA ferrite driver, 2.5" voice coil	Customized BEYMA ferrite driver, 3" voice coil	/			
	LF				Customized AUDIOCENTER ferrite driver, 4" voice coil			
Crossover and Slope		Controlled by DSP						
Signal Input / Output Connectors		Female XLR input, male XLR output						
Power Input Connectors		Power Connector						
Power Output Connectors		Power Connector				/		
Working Voltage		100V-130V(60Hz);220V-240V(50/60Hz)						
DSP								
Processor		96KHz signal sampling frequency, 24bit precision						
Default program		Linear , HFX , W/SUB		Fixed System Preset	80Hz , 100Hz , 120Hz			
AMPLIFIER								
Amplifier		Class D						
Power(RMS standards)		1600W				2800W		
Frequency Response (1W 8Ω 2ch)		20Hz-20KHz(±0.5dB)				20Hz-6KHz(±0.5dB)		
Intermodulation Distortion (20Hz-20KHz, half power)		< 0.05%						
Total Harmonic Distortion (20Hz-20KHz, Rated power 8Ω)		< 0.05%						
Cooling		Cooling with fans						
Protection	DC protection	√						
	Short circuit protection	√						
	Overheat protection	√						
	Output overload protection	√						
	Soft startup protection	√						
	Overvoltage protection	√						
	Undervoltage protection	√						
CABINET								
Cabinet		High density Russian birch plywood CNC made						
Optional Accessories		Flight case with 100mm wheels / Durable rain bag / D shackle / Stainless steel wire / Flying frame						
Dimensions(W×H×D)		590x236x500mm	742x302x695mm	899x344.5x647.5mm	590x639x800mm	742x600x828mm	1080x595x760mm	
Net Weight		25.0kg	38.5kg	59.0kg	63.0kg	90.0kg	101.0kg	
Technical Support and After-sales Service		Global application support team, EASE GLL files						

AUDIOCENTER Reserves the rights to change specifications without prior notice in case

◆ Trouble shooting

Symptom	Possible reasons	Solution
Power LED not light	Cable not connected correctly	Connect the cable correctly
No sound	<ol style="list-style-type: none"> 1. Cable not connected correctly. 2. Or too small gain. 	<ol style="list-style-type: none"> 1. Correct with input socket correctly. 2. Adjust speaker output gain into bigger.
Feedback in the sound	<ol style="list-style-type: none"> 1. Microphone is toward the speaker. 2. Sound is too high. 3. Wrong preset used. 	<ol style="list-style-type: none"> 1. Keep speakers out of the microphone response area. 2. Lower the output gain.
Sound discrepancy from different speakers	<ol style="list-style-type: none"> 1. Different gain for different speakers. 2. Different preset for different speakers. 3. Subwoofers are out phase. 	<ol style="list-style-type: none"> 1. Put the same gain for different speakers. 2. Use the same preset for different speakers. 3. Make the sub in phase.
Sound distortion	<ol style="list-style-type: none"> 1. Input volume is too big. 2. Output volume is too big. 	<ol style="list-style-type: none"> 1. Reduce the input volume of the equipments. 2. Reduce the output gain of the speakers, making the Limiter LED lighter a bit.
Not enough SPL while full range speakers used together with subs	Subs might be out of phase.	Adjust the phase of subs.

★ Please consult distributor if there are still problems



Dynamic Audio Solutions