



MIRAGE Q6 PAK



User Manual

©2022 ADJ Products, LLC all rights reserved. Information, specifications, diagrams, images, and instructions herein are subject to change without notice. ADJ Products, LLC logo and identifying product names and numbers herein are trademarks of ADJ Products, LLC. Copyright protection claimed includes all forms and matters of copyrightable materials and information now allowed by statutory or judicial law or hereinafter granted. Product names used in this document may be trademarks or registered trademarks of their respective companies and are hereby acknowledged. All non-ADJ Products, LLC brands and product names are trademarks or registered trademarks of their respective companies.

ADJ Products, LLC and all affiliated companies hereby disclaim any and all liabilities for property, equipment, building, and electrical damages, injuries to any persons, and direct or indirect economic loss associated with the use or reliance of any information contained within this document, and/or as a result of the improper, unsafe, insufficient and negligent assembly, installation, rigging, and operation of this product.

DOCUMENT VERSION



Due to additional product features and/or enhancements, an updated version of this document may be available online.

Please check www.adj.com for the latest revision/update of this manual before beginning installation and/or programming.

Date	Document Version	Software Version	DMX Channels	Notes
07/22/2021	1.0	V1.00	4 / 6 / 7 / 8 / 9A / 9B / 10 / 11 / 12 / 15 / 18 channels	Initial Release
11/05/2021	1.1	N/C	No Change	Updated Key Features, Safety Guidelines, Overview, Installation, In-Case Charging, System Menu, DMX Traits, Dimensional Drawing, Specifications; Removed DMX Setup.
01/20/2022	1.2	V1.02	No Change	Updated System Menu, Dimensional Drawings, and Specifications.
05/06/2022	1.3	N/C	No Change	Updated UC IR Remote.
05/12/2022	1.4	V1.03	No Change	Updated System Menu to add Saver 14 mode; updated Specifications.

Europe Energy Saving Notice

Energy Saving Matters (EuP 2009/125/EC)

Saving electric energy is a key to help protecting the environment. Please turn off all electrical products when they are not in use. To avoid power consumption in idle mode, disconnect all electrical equipment from power when not in use. Thank you!

TABLE OF CONTENTS

General Information	4
Key Features Warranty Returns	5
Limited Warranty (USA Only)	6
Safety Guidelines	7
Overview	9
DMX Addressing	11
Wifly Setup	12
UC IR Remote	14
Installation	15
In-Case Charging	18
Control Panel	19
System Menu	20
DMX Traits	23
Color Macros	37
Color Temperature	38
Dimmer Curves	39
Cleaning & Maintenance Daisy Chain Power Linkage	40
Torque Settings	41
Fuse Replacement Battery Life	42
Dimensional Drawings	43
Specifications	44

GENERAL INFORMATION

Introduction: Congratulations on your purchase of the ADJ Mirage Q6 Pak! This package includes 6 ADJ Mirage Q IP battery-operated, IP65-rated, RGBA LED chrome uplights, plus a charging flight case with storage and charging capacity for these devices. All included devices have been designed to perform reliably for years when the guidelines in this booklet are followed. Please read and understand the instructions in this manual carefully and thoroughly before attempting to operate the included devices. These instructions contain important information regarding safety during use and maintenance.

Please keep this manual with the device for future reference.

Customer Support: Contact ADJ Service for any product related service and support needs. Also visit forums.adj.com with questions, comments or suggestions.

Parts: To purchase parts online visit:

<http://parts.adj.com> (US)

<http://www.adjparts.eu> (EU)

ADJ SERVICE USA - Monday - Friday 8:00am to 4:30pm PST

Voice: 800-322-6337 | Fax: 323-582-2941 | support@adj.com

ADJ SERVICE EUROPE - Monday - Friday 08:30 to 17:00 CET

Voice: +31 45 546 85 60 | Fax: +31 45 546 85 96 | support@adj.eu

ADJ PRODUCTS LLC USA

6122 S. Eastern Ave. Los Angeles, CA. 90040

323-582-2650 | Fax 323-532-2941 | www.adj.com | info@adj.com

ADJ SUPPLY Europe B.V

Junostraat 2 6468 EW Kerkrade, The Netherlands

+31 (0)45 546 85 00 | Fax +31 45 546 85 99

www.adj.eu | info@adj.eu

ADJ PRODUCTS GROUP Mexico

AV Santa Ana 30 Parque Industrial Lerma, Lerma, Mexico 52000

+52 (728) 282-7070

WARNING! To prevent or reduce the risk of electrical shock or fire, do not expose the charging flight case to rain or moisture.

CAUTION! There are no user serviceable parts inside these units. Do not attempt any repairs yourself, as doing so will void your manufacturer's warranty. In the unlikely event your unit may require service, please contact ADJ Products, LLC.

Do not discard the shipping carton in the trash. Please recycle when ever possible.

KEY FEATURES

FIXTURE FEATURES

- IP65 Outdoor Rated
- 15 Degree Beam Angle
- 4-touch button OLED display on rear panel
- Built-in WiFLY EXR wireless DMX: Up to 2,500 feet (760M) when used with ADJ's WiFLY EXR Battery Transceiver
- 64 built-in Color Macros
- Flicker Free Operation
- Electronic Dimming: 0 - 100% with 6 dim modes and 4 dim curves
- Rechargeable Lithium-Ion Battery
- Battery Charge Time: 7 Hours
- Battery Life: 40 hours (single color)
- Motion-Activated Alarm Feature

CASE FEATURES

- Houses / Transports and Charges (6) MIRAGE Q6 IP™ fixtures
- Power Input: AC100VAC~240VAC, 50/60Hz
- Charge status indicator

WARRANTY RETURNS

All returned service items, whether under warranty or not, must be freight pre-paid and accompanied by a return authorization (R.A.) number. The R.A. number must be clearly written on the outside of the return package. A brief description of the problem as well as the R.A. number must also be written down on a piece of paper included in the shipping carton. If the unit is under warranty, you must provide a copy of your proof of purchase invoice. You may obtain an R.A. number by contacting our customer support team. All packages returned to the service department not displaying an R.A. number on the outside of the package will be returned to the shipper.

LIMITED WARRANTY (USA ONLY)

- A. ADJ Products, LLC hereby warrants, to the original purchaser, ADJ Products, LLC products to be free of manufacturing defects in material and workmanship for a prescribed period from the date of purchase (see specific warranty period on reverse). This warranty shall be valid only if the product is purchased within the United States of America, including possessions and territories. It is the owner's responsibility to establish the date and place of purchase by acceptable evidence, at the time service is sought.
- B. For warranty service, you must obtain a Return Authorization number (RA#) before sending the product back—please contact ADJ Products, LLC Service Department at 800-322-6337. Send the product only to the ADJ Products, LLC factory. All shipping charges must be prepaid. If the requested repairs or service (including parts replacement) are within the terms of this warranty, ADJ Products, LLC will pay return shipping charges only to a designated point within the United States. If the entire instrument is sent, it must be shipped in its original package and packaging material. No accessories should be shipped with the product. If any accessories are shipped with the product, ADJ Products, LLC shall incur no liability whatsoever for loss of or damage to any such accessories, nor for the safe return thereof.
- C. This warranty is void if the product serial number and/or labels are altered or removed; if the product is modified in any manner which ADJ Products, LLC concludes, after inspection, affects the reliability of the product; if the product has been repaired or serviced by anyone other than the ADJ Products, LLC factory unless prior written authorization was issued to purchaser by ADJ Products, LLC; if the product is damaged because it was not properly maintained as set forth in the product instructions, guidelines and/or user manual.
- D. This is not a service contract, and this warranty does not include maintenance, cleaning, or periodic checkup. During the period specified above, ADJ Products, LLC will replace defective parts at its expense with new or refurbished parts, and will absorb all expenses for warranty service and repair labor by reason of defects in material or workmanship. The sole responsibility of ADJ Products, LLC under this warranty shall be limited to the repair of the product, or replacement thereof, including parts, at the sole discretion of ADJ Products, LLC. All products covered by this warranty were manufactured after August 15, 2012, and bear identifying marks to that effect.
- E. ADJ Products, LLC reserves the right to make changes in design and/or improvements upon its products without any obligation to include these changes in any products theretofore manufactured.
- F. No warranty, whether expressed or implied, is given or made with respect to any accessory supplied with products described above. Except to the extent prohibited by applicable law, all implied warranties made by ADJ Products, LLC in connection with this product, including warranties of merchantability or fitness, are limited in duration to the warranty period set forth above. And all warranties, whether expressed or implied, including warranties of merchantability or fitness, are limited in duration to the warranty period set forth above. The consumer's and/or dealer's sole remedy shall be such repair or replacement as is expressly provided above; and under no circumstances shall ADJ Product, LLC be liable for any loss and/or damage, direct and/or consequential arising out of the use of, and/or inability to use this product.
- G. This warranty is the only written warranty applicable to ADJ Products, LLC products, and supersedes all prior warranties and written descriptions of warranty terms and conditions heretofore published.

MANUFACTURER'S LIMITED WARRANTY PERIODS:

- Non-LED Lighting Products = 1-Year (365 Days) (Including Special Effect Lighting, Intelligent Lighting, UV lighting, Strobes, Fog Machines, Bubble Machines, Mirror Balls, Par Cans, Trussing, Lighting Stands, Power/Data Distribution, etc. excluding LED and lamps)
- Laser Products = 1-Year (365 Days) (excluding laser diodes which have a 6-Month Limited Warranty)
- LED Products = 2-Year (730 Days) (excluding batteries which have a 180 Day Limited Warranty)
- NOTE: 2-Year (730 Days) Limited Warranty ONLY applies to product purchased within the United States. StarTec Series = 1-Year (365 Days) (excluding batteries which have a 180 Day Limited Warranty)
- ADJ DMX Controllers = 2 Year (730 Days)
- American Audio Products = 1 Year (365 Days)

SAFETY GUIDELINES

For Your Own Personal Safety, Please Read and Understand This Manual Completely Before You Attempt To Install Or Operate This Unit!

- Be sure to save the packing carton in the unlikely event the device may have to be returned for service.
- Do not spill water or other liquids into or on to the charging device or flight case.
- Be sure that the local power outlet matches the required voltage for the device.
- Do not open up the device for any reason. There are no user serviceable parts inside.
- Disconnect the device's main power when left unused for long periods of time.
- Never connect this device to a dimmer pack.
- Do not attempt to operate this device if it has been damaged in any way.
- Never operate this device with the cover removed.
- To reduce the risk of electrical shock or fire, do not expose the charging device or the flight case to rain or moisture.
- Do not attempt to operate this device if the power cord has been frayed or broken.
- Do not attempt to remove or break off the ground prong from the electrical cord. This prong is used to reduce the risk of electrical shock and fire in case of an internal short.
- Disconnect from main power before making any type of connection.
- Never block the ventilation holes. Always be sure to mount this device in an area that will allow proper ventilation. Allow about 6" (15cm) between this device and a wall.
- This flight case and charging devices are intended for indoor use only. Use of these devices outdoors voids all warranties.
- Always mount this unit in a safe and stable matter.
- Please route your power cord out of the way of foot traffic. Power cords should be routed so they are not likely to be walked on, or pinched by items placed upon or against them

Operating temperature range for this fixture is 32 to 113 degrees F (0 to 45 degrees C). Do not operate this device when ambient temperature falls outside this range!

Keep flammable materials away from this fixture!

FLIGHT CASE AND CHARGING DEVICES ARE DESIGNED FOR INDOOR USE ONLY! DO NOT EXPOSE TO RAIN OR MOISTURE!

The device should be serviced by qualified service personnel when:

- A. The power-supply cord or the plug has been damaged.
- B. Objects have fallen on, or liquid has been spilled into, the device.
- C. The flight case or charging devices have been exposed to rain or water.
- D. The appliance does not appear to operate normally or exhibits a marked change in performance.

SAFETY GUIDELINES

FLIGHT CASE LID

When opening the flight case, the lid must be locked in place manually. The lid support prop is located on the right-hand side of the flight case, near the power cable storage compartment. The lower end of the prop is fixed to the flight case, and the disconnected upper end contains a cut-out groove.

Once the lid has been opened, lift the upper end of the support bar and attach it to the recessed catch on the underside of the lid, along the right-hand side. Make sure that the catch is fully seated in the support bar's groove before reaching into the flight case.

FAILURE TO PROPERLY FOLLOW THIS PROCEDURE CAN RESULT IN PERSONAL INJURY OR DAMAGE TO THE DEVICE, AS THE LID MAY SWING SHUT WITHOUT WARNING!

See the illustration below for reference.



OVERVIEW

FLIGHT CASE

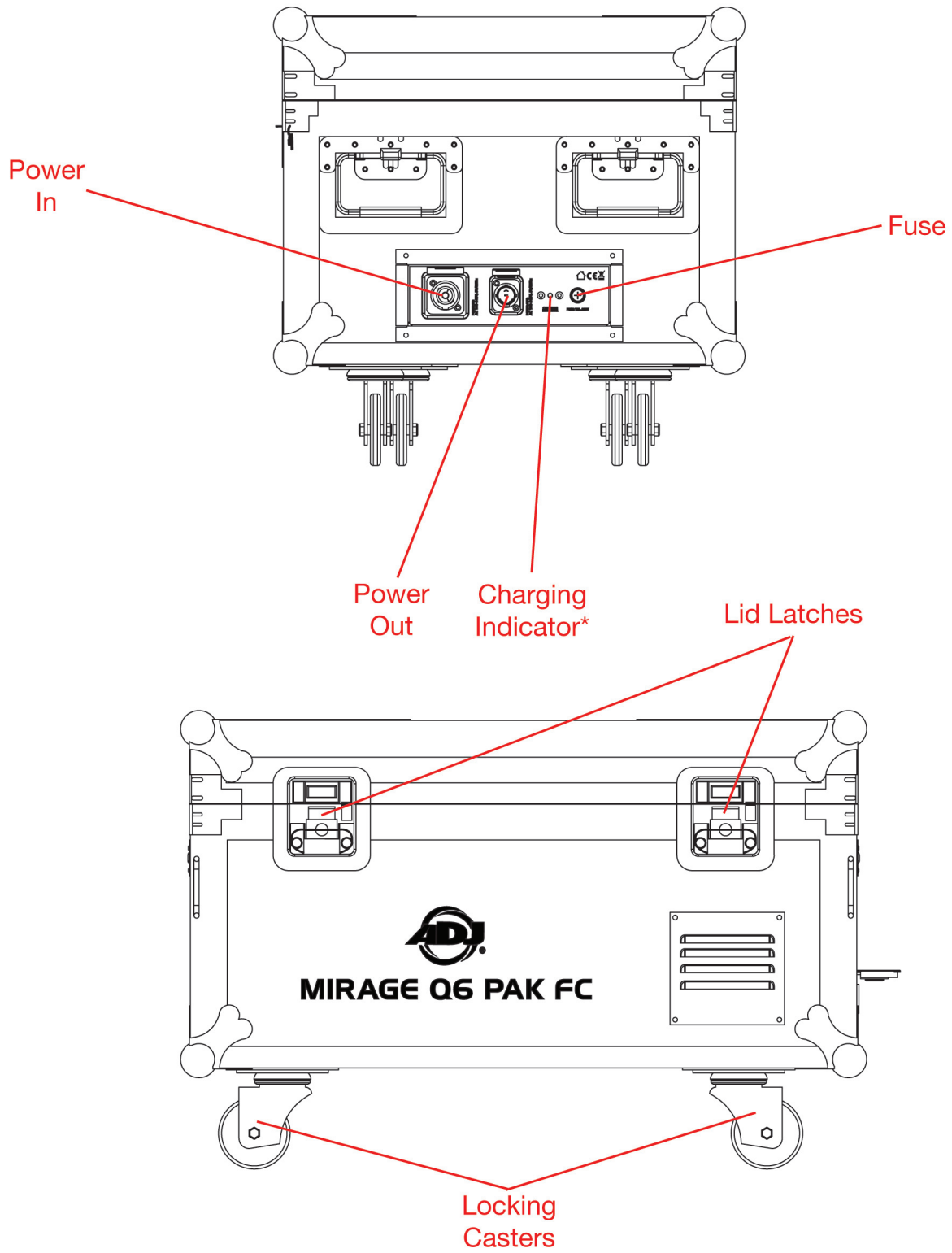

**Note: Charge indicator is red when charging, and green when complete. Charge indicator on the case displays charge status of the entire six-unit set. For individual charge status, please refer to the charge indicator on each individual unit.*

OVERVIEW

LIGHTING FIXTURE

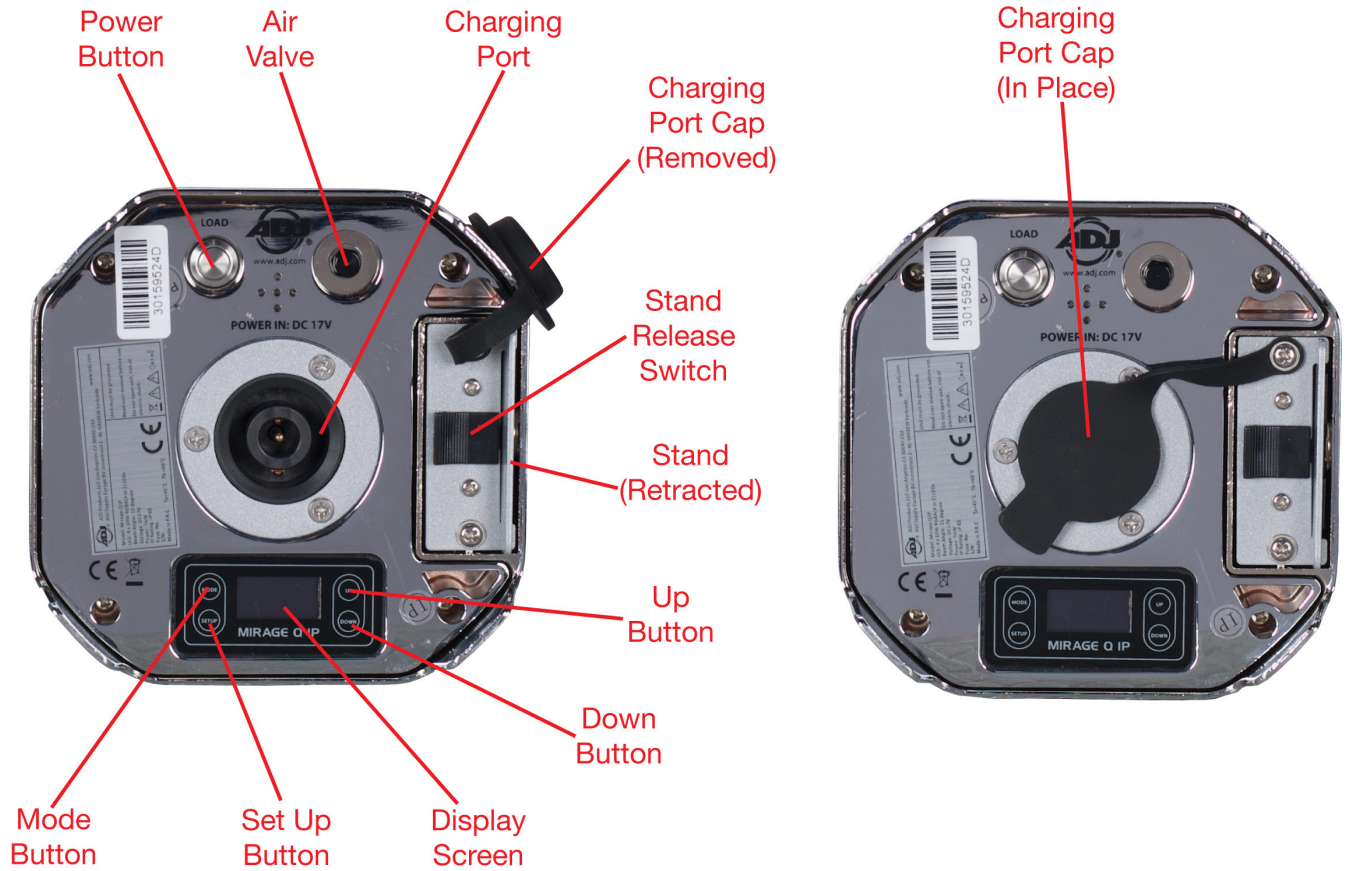

DMX ADDRESSING

All fixtures should be given a DMX starting address when operating with a DMX controller, in order to ensure that the correct fixture responds to the correct control signal. This digital starting address is the channel number from which the fixture starts to “listen” to the digital control signal sent out from the DMX controller. This starting DMX address is assigned by setting the correct DMX address on the digital control display on the fixture.

You can set the same starting address for all fixtures or a group of fixtures, or set different addresses for each individual fixture. Setting all fixtures to the same DMX address will cause all fixtures to react in the same way. In this case, please note that changing the settings of one channel will affect all the fixtures simultaneously.

If you set each fixture to a different DMX address, each unit will start to “listen” to the channel number you have set, based on the quantity of DMX channels of each fixture. That means changing the settings of one channel will only affect the selected fixture.

As an example, when operating this fixture model in 4 channel mode, you should set the starting DMX address of the first unit to 1, the second unit to 5 (4 + 1), the third unit to 9 (4 + 4 + 1), and so on. (See the chart below for more details.)

Channel Mode	Unit 1 Addr	Unit 2 Addr	Unit 3 Addr	Unit 4 Addr
4-Ch	1	5	9	13
6-Ch	1	7	13	19
7-Ch	1	8	15	22
8-Ch	1	9	17	25
9-Ch	1	10	19	28

Channel Mode	Unit 1 Addr	Unit 2 Addr	Unit 3 Addr	Unit 4 Addr
10-Ch	1	11	21	31
11-Ch	1	12	23	34
12-Ch	1	13	25	37
15-Ch	1	16	31	46
18-Ch	1	19	37	55

WIFLY SETUP

These devices do not feature physical DMX connector ports. Therefore, in order to utilize DMX control, the user must first set up the devices to run wireless DMX control. Follow the directions below to configure wireless DMX control:

1. First, select the DMX Channel Mode for that you would like the device to operate in. Press MODE until the the “DMX Settings” menu is displayed on the screen. Use the UP and DOWN buttons to scroll to “DMX Channel Mode,” then press the SETUP button.
2. Use UP and DOWN to scroll through the DMX Channel Mode options, then press SETUP to confirm your selection.
3. Next, enable the device’s Wifly capability. Press MODE until the “Personality” menu is displayed on the screen, then use UP and DOWN to scroll to “Wifly Settings” and press SETUP.
4. Use UP and DOWN to scroll to “Enable Wifly,” then press SETUP to select this option.
5. Use UP and DOWN once again to toggle this setting to “Yes,” then confirm by pressing SETUP.
6. Next, select the Wifly channel. Press MODE until the “Personality” menu is displayed on the screen again, then use UP and DOWN to scroll to “Wifly Settings” and press SETUP.
7. Use UP and DOWN to scroll to “Set Wifly Channel,” then press SETUP again.
8. Now use UP and DOWN to scroll to your desired Wifly channel. Selectable values range from 00 to 14.
9. Finally, set the DMX address. Press the MODE button until the “DMX Settings” menu is displayed on the screen, then use UP and DOWN to scroll to “DMX Address,” then press SETUP.
10. Use the UP and DOWN buttons to scroll to your desired DMX address, then press SETUP to confirm your selection. Available values range from 001 to 512. Refer to the ***DMX Addressing*** section of this manual for detailed guidance. Repeat these steps for each individual unit that you wish to use.

WIFLY SETUP

WIRELESS SETUP

There are many factors that can affect and/or interrupt a wireless signal, including walls, glass, metal, objects, and people. Therefore, the following guidelines are recommended in order to maximize the chances of having a clear path for the wireless signal to reach the device:

- Install the device a minimum of 9.8 ft (3m) above audiences and/or ground level.
- Arrange the wireless antenna in an upright, vertical position.
- Position devices in direct line of sight of the transmitting controller.

Careful planning and testing of the selected installation location is critical to ensure optimum and reliable wireless operation.



UC IR REMOTE

The unit can only be controlled when it has been set to Primary mode. The unit will NOT respond to commands when it has been set to Secondary mode. When using the UC IR to control multiple units that are operating in primary/secondary mode, follow these steps to set up the units:

1. Power on the unit, and press MODE to scroll to the “Personality” menu.
2. Press SETUP, then use the UP and DOWN buttons to scroll to “Primary” or “Secondary” depending on the how you would like this unit to operate. Press SETUP to make your selection, and then use the UP and DOWN buttons to switch the option to ON.
3. Press SETUP to confirm and return to the “Personality” menu.
4. Use UP and DOWN to scroll to “WiFly Settings” and select “Set WiFly Channel.” Press SETUP and use UP and DOWN to set the unit to your desired WiFly channel. Repeat these steps for each unit. Please note that all units should be set to the same Wifly channel.

NOTES:

- Only one unit should be configured as the primary, while all the other units should be configured as secondaries.
- All units in the system should be set to the same WiFly channel. If all units are set to the same WiFly channel, and the units do not sync up and/or respond to commands, try using a different WiFly channel.
- All units should be set to the same DMX channel mode.
- If fixtures fail to sync, verify that all settings mentioned above are the same, then power all devices off, then switch them on again to re-establish the link.

CONTROLS

- **Standby:** Turns all LEDs off.
- **Full On:** Turns all LEDs on.
- **Fade/Gobo:** Set unit to color fade mode. Use “Dimmer+” and “Dimmer-” buttons to increase or decrease fade speed.
- **Strobe:** Set unit to strobe setting. Use “Dimmer+” and “Dimmer-” buttons to increase or decrease strobe rate.
- **Color:** Set unit to static color display. Use the number keys to select one of the 64 available color options, as listed in the **Color Macros** section of this manual. Use the “Show 0” button to enter in the number 0. *For example, Macro 10 is selected by pressing the “Color” button, followed by the “1” button, and then the “Show 0” button; Macro 5 is selected by pressing the “Color” button, followed by the “5” button.*
- **1 - 9 Buttons:** Used to select the desired macro or show.
- **Sound On / Sound Off:** These buttons have no defined function for this unit.
- **Show 0:** Set the unit to Show mode. Use the number buttons to select one of the 13 available internal program options, and use the “Show 0” button to enter in the number 0.



INSTALLATION

IP RATING

The Mirage Q IP is **IP65** rated. It is completely dust tight, and is protected against low-pressure directed jets of water from any direction. **The charging devices and flight case are not IP-rated, and are intended for use in dry, indoor conditions only.**

FLAMMABLE MATERIAL WARNING!

Keep device a minimum of 5.0 feet (1.5m) away from flammable material and/or pyrotechnics.

ELECTRICAL CONNECTIONS

A qualified electrician should be used for all electrical connections and/or installations.

DO NOT INSTALL THE DEVICE IF YOU ARE NOT QUALIFIED TO DO SO!

The unit **MUST** be installed following all local, national, and country commercial electrical and construction codes and regulations.

Before installing or mounting any device, a professional equipment installer **MUST** be consulted to determine whether the mounting structure or surface is properly certified to safely support the combined weight of the fixture, clamps, cables, and accessories.

Operating temperature range is **32 to 113 degrees F (0 to 45 degrees C)**. Do not operate the device if ambient temperatures fall outside of this range.

This fixture should be installed in areas outside walking paths, seating areas, and areas where unauthorized personnel might be able to reach the device by hand.

NEVER stand directly below the fixture when rigging, removing, or servicing.

Allow approximately 15 minutes for the fixture to cool down before servicing.

INSTALLATION

CLAMP INSTALLATION

The Mirage Q IP features a mounting clamp attachment point on the side of the device (see the illustration below). When mounting the fixture to a truss or any other suspended or overhead installation, be sure to secure appropriately rated clamps (not included) to the clamp attachment point.

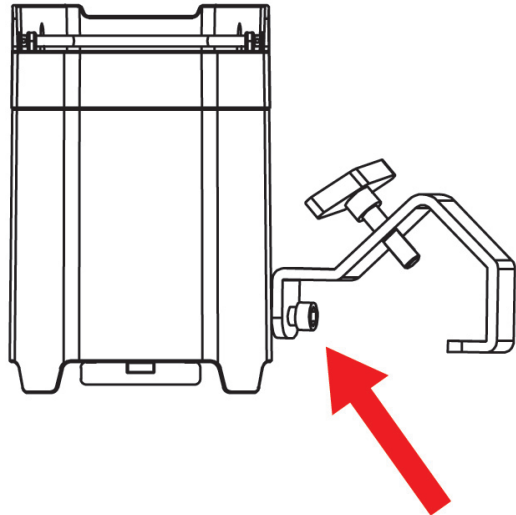

**MOUNTING CLAMP
ATTACHMENT POINT**

RIGGING

Overhead rigging requires extensive experience, including but not limited to: calculating working load limits, understanding the installation material being used, and periodic safety inspection of all installation material and the fixture itself. If you lack these qualifications, do not attempt to perform the installation yourself. Improper installation can result in bodily injury.

CHARGING PORT CAP

In order to maintain IP65 integrity, the charge port of each device must be sealed off using the attached rubber cap when the charging port is not in use.

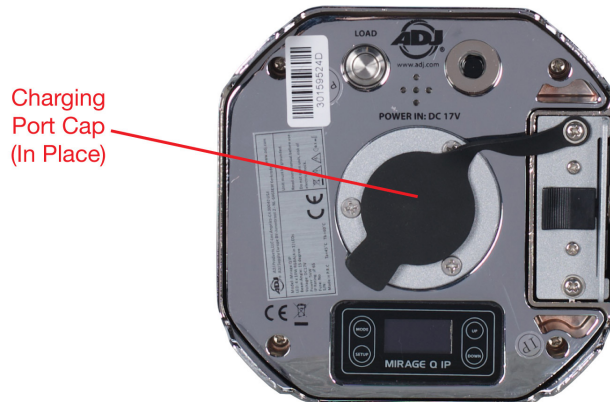

INSTALLATION

KICKSTAND FOR FLOOR PLACEMENT

The Mirage Q IP can also be placed on the floor to provide an uplighting display, and features a retractable kickstand that allows the device to be angled in the direction of the desired display.

Make sure that the rubber cap is secured over the charge port to maintain the device's IP65 rating.

To deploy the kickstand, simply toggle the switch on the underside of the device, near the power charging port (1). The kickstand can then be deployed from the underside (2) at various notched increments, allowing a maximum angle of 35 degrees from the vertical axis (3).

Note: If set and activated, the alarm will be triggered by any movement of the device, including knocking over the device. The alarm will sound and the device will strobe red for the amount of time that was set in the "Alarm Time" setting, but will automatically stop when the device is returned to its place. Please be aware of this feature in the event that you decide to re-locate or re-position the device after the initial setup!

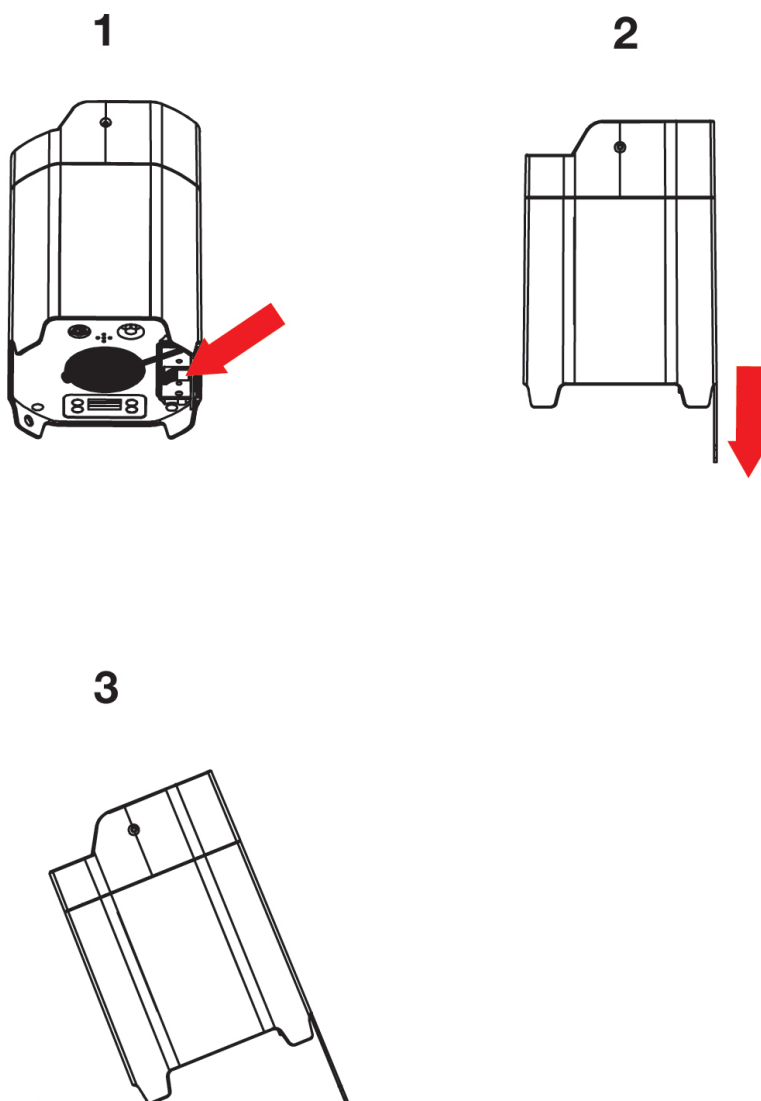

IN-CASE CHARGING

1. Lock the wheel casters by pressing down on the levers located near each caster.
2. Connect power cables to both the power in and power out ports, if desired. Please refer to the **Daisy Chain Power Linkage** section of this manual for details.
3. Remove the rubber cap from the charging port for each unit. **NOTE: It is recommended to fold the rubber cap back and over the closest CORNER of the device before placing it into its charging slot in the flight case. Refer to the top left image below.**
 - When placing the fixture in the case slot, the rubber cap should tuck neatly into the gap in the corner of the slot (see bottom image).
 - Do NOT fold the rubber caps back over the side edges of the unit, as the device will not fit in the flight case compartment this way. Refer to the top right image below.
 - Do NOT allow the rubber cap to get caught underneath the device, as this will interfere with the charging of the device.

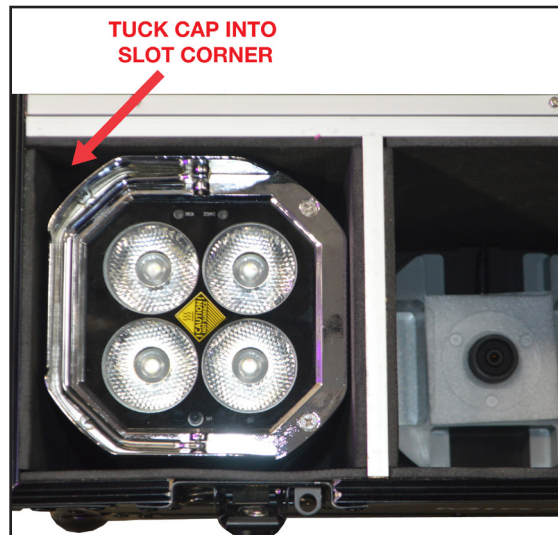

4. Place an ADJ Mirage Q IP device in any of the device slots in the flight case. Up to 6 devices can be accommodated. The charge indicator located beside the power ports will illuminate to indicate that your device is charging. **It is strongly recommended to leave the case lid open during charging.**

CONTROL PANEL

This fixture includes an easy to navigate control panel display, from which all necessary settings and adjustments can be made. Press the **MODE** button to scroll through the main menu options, then press **SET UP** to select the currently displayed option. Then use the **UP** and **DOWN** buttons to scroll through the sub-menu options until reaching the desired setting. Press the **MODE** button at any time to return to the main menu without making any adjustments.

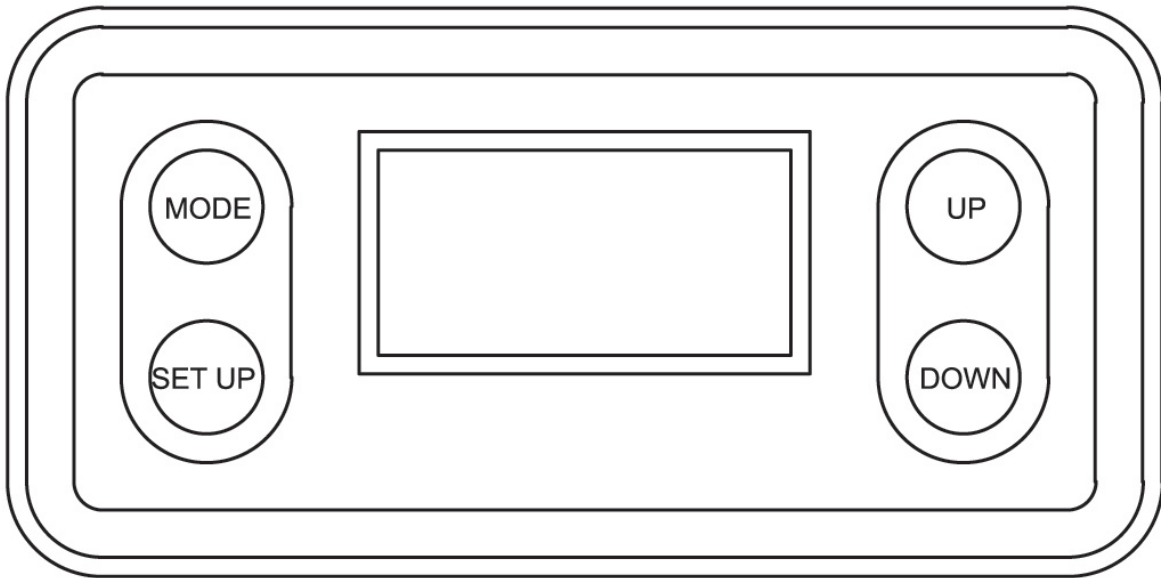

SYSTEM MENU

DMX SETTINGS	DMX Address	001 - 512		
	DMX Channel Mode	4-Ch		
		6-Ch		
		7-Ch		
		8-Ch		
		9A-Ch		
		9B-Ch		
		10-Ch		
		11-Ch		
		12-Ch		
		15-Ch		
	18-Ch			
	No DMX Status	Hold Last		Holds last DMX values received before signal loss
		Blackout		Takes all channels to DMX value of 0 when signal is lost
		Manual Settings		All channels go to last manual settings when signal is lost
Internal Programs			Unit runs last set internal program when signal is lost	

CONTINUED ON NEXT PAGE

SYSTEM MENU

PERSONALITY	Primary	On / Off		
	Secondary	On / Off		
	IR Remote	On / Off		
	Dim Modes	Standard		
		Stage		
		TV		
		Architectural		
		Theatre		
		Stage 2		
		Dim Delay	0 - 99	
	Wifly Settings	Set Wifly Channel	00 - 14	
		Enable Wifly	Yes / No	
		Disable Wifly	Yes / No	
		Wifly On With Power	Yes / No	Set whether Wifly automatically turns on when unit is powered on
	Display	Screen Saver Delay	Off, 1-10s	
		Touch Screen Lock	Off	
			30 s	
			1 min	
		Rotate Display 180	Yes / No	
	Language	Passcode = 050	English	
			Spanish	
	Alarm (Passcode = 011)	On / Off		Set whether alarm will sound when unit is moved, alarm will sound and unit strobes red for selected alarm time
		Alarm Time	10s / 20s / 30s / 40s / 50s / 60s	
Service	Passcode = 011	Factory Restore	Yes / No	

CONTINUED ON NEXT PAGE

SYSTEM MENU

MANUAL CONTROL	Red	000 - 255		
	Green	000 - 255		
	Blue	000 - 255		
	Amber	000 - 255		
	Color Macros	000 - 255		See Color Macros section for details
	Internal Programs	000 - 255		
	Program Speed	000 - 255		
	Program Fade	000 - 255		
	Strobe	000 - 255		
	Master Dimmer	000 - 255		
INTERNAL PROGRAMS	Program 0	Speed	1 - 16	Speed: 1 is slowest, 16 is fastest Fade: 1 is most fade, 16 is least fade
		Fade	1 - 16	
	Program 1	Speed	1 - 16	
		Fade	1 - 16	
	
	Program 13	Speed	1 - 16	
Fade		1 - 16		
INFORMATION	LED Temperature	xxx F		
		xxx C		
	Software Version			
BATTERY	Charging Time	xx Hours	Time to full charge	
	Current Life	xxx%	Remaining life	
	Operation Mode	Standard 6		Approx 6 hrs
		Saver 10		Approx 10 hrs
Saver 14		Approx 40 hrs (when operating on a single LED)		

DMX TRAITS

4-Channel Mode

CHANNEL	DMX VALUES	DESCRIPTION
1	000 - 255	Red , 0-100%
2	000 - 255	Green , 0-100%
3	000 - 255	Blue , 0-100%
4	000 - 255	Amber , 0-100%

6-Channel Mode

CHANNEL	DMX VALUES	DESCRIPTION
1	000 - 255	Red , 0-100%
2	000 - 255	Green , 0-100%
3	000 - 255	Blue , 0-100%
4	000 - 255	Amber , 0-100%
5		Strobe
	000 - 031	LEDs Off
	032 - 063	LEDs On
	064 - 095	Strobe effect, slow to fast
	096 - 127	LEDs On
	128 - 159	Pulse, effect in sequence
	160 - 191	LEDs On
	192 - 223	Random strobe effect, slow to fast
	224 - 255	LEDs On
6	000 - 255	Dimmer Intensity , 0-100%

DMX TRAITS

7-Channel Mode

CHANNEL	DMX VALUES	DESCRIPTION
1	000 - 255	Red , 0-100%
2	000 - 255	Green , 0-100%
3	000 - 255	Blue , 0-100%
4	000 - 255	Amber , 0-100%
5		Strobe
	000 - 031	LEDs Off
	032 - 063	LEDs On
	064 - 095	Strobe effect, slow to fast
	096 - 127	LEDs On
	128 - 159	Pulse, effect in sequence
	160 - 191	LEDs On
	192 - 223	Random strobe effect, slow to fast
	224 - 255	LEDs On
6	000 - 255	Dimmer Intensity , 0-100%
7		Dim Mode
	000 - 020	Standard
	021 - 040	Stage
	041 - 060	TV
	061 - 080	Architectural
	081 - 100	Theatre
	101 - 120	Stage 2
	121 - 140	Dim Speed, fast to slow (0.1s - 10.0s)
	141 - 255	Default

DMX TRAITS

8-Channel Mode

CHANNEL	DMX VALUES	DESCRIPTION
1	000 - 255	Red , 0-100%
2	000 - 255	Red Fine
3	000 - 255	Green , 0-100%
4	000 - 255	Green Fine
5	000 - 255	Blue , 0-100%
6	000 - 255	Blue Fine
7	000 - 255	Amber , 0-100%
8	000 - 255	Amber Fine

9A-Channel Mode

CHANNEL	DMX VALUES	DESCRIPTION
1	000 - 255	Red , 0-100%
2	000 - 255	Green , 0-100%
3	000 - 255	Blue , 0-100%
4	000 - 255	Amber , 0-100%
5		Strobe
	000 - 031	LEDs Off
	032 - 063	LEDs On
	064 - 095	Strobe effect, slow to fast
	096 - 127	LEDs On
	128 - 159	Pulse, effect in sequence
	160 - 191	LEDs On
	192 - 223	Random strobe effect, slow to fast
	224 - 255	LEDs On
6	000 - 255	Dimmer Intensity , 0-100%
7		Auto Programs
	000 - 010	Off
	011 - 026	Auto Program 1
	027 - 043	Auto Program 2
	044 - 060	Auto Program 3
	061 - 076	Auto Program 4

CONTINUED ON NEXT PAGE

DMX TRAITS

9A-Channel Mode (cont'd)

CHANNEL	DMX VALUES	DESCRIPTION
7		Auto Programs (cont'd)
	077 - 093	Auto Program 5
	094 - 110	Auto Program 6
	111 - 126	Auto Program 7
	127 - 143	Auto Program 8
	144 - 160	Auto Program 9
	161 - 176	Auto Program 10
	177 - 193	Auto Program 11
	194 - 210	Auto Program 12
	211 - 226	Auto Program 13
	227 - 255	No Function
8	000 - 255	Auto Program Speed , slow to fast
9	000 - 255	Auto Program Fade , 100% to 0%

9B-Channel Mode

CHANNEL	DMX VALUES	DESCRIPTION
1	000 - 255	Red , 0-100%
2	000 - 255	Green , 0-100%
3	000 - 255	Blue , 0-100%
4	000 - 255	Amber , 0-100%
5	000 - 255	Color Macros , see Color Macros section
6	000 - 255	Color Temperature , 2400K-9900K, see Color Temperature section
7		Strobe
	000 - 031	LEDs Off
	032 - 063	LEDs On
	064 - 095	Strobe effect, slow to fast
	096 - 127	LEDs On
	128 - 159	Pulse, effect in sequences
	160 - 191	LEDs On
	192 - 223	Random strobe effect, slow to fast
	224 - 255	LEDs On

CONTINUED ON NEXT PAGE

DMX TRAITS

9B-Channel Mode (cont'd)

CHANNEL	DMX VALUES	DESCRIPTION
8	000 - 255	Dimmer Intensity , 0-100%
9	000 - 255	Dimmer Fine

10-Channel Mode

CHANNEL	DMX VALUES	DESCRIPTION
1	000 - 255	Red , 0-100%
2	000 - 255	Green , 0-100%
3	000 - 255	Blue , 0-100%
4	000 - 255	Amber , 0-100%
5	000 - 255	Color Temperature , 2400K-9900K, see Color Temperature section
6		Strobe
	000 - 031	LEDs Off
	032 - 063	LEDs On
	064 - 095	Strobe effect, slow to fast
	096 - 127	LEDs On
	128 - 159	Pulse, effect in sequences
	160 - 191	LEDs On
	192 - 223	Random strobe effect, slow to fast
	224 - 255	LEDs On
7	000 - 255	Dimmer Intensity , 0-100%
8	000 - 255	Dimmer Fine
9		Dim Curves
	000 - 020	Linear
	021 - 040	Square
	041 - 060	Inv. Squa
	061 - 080	S. Curve
	081 - 255	No Function
10		Refresh Rates
	000 - 015	Default
	016 - 030	900 Hz
	031 - 045	1000 Hz

CONTINUED ON NEXT PAGE

DMX TRAITS

10-Channel Mode (cont'd)

CHANNEL	DMX VALUES	DESCRIPTION
10		Refresh Rates (cont'd)
	046 - 060	1100 Hz
	061 - 075	1200 Hz
	076 - 090	1300 Hz
	091 - 105	1400 Hz
	106 - 120	1500 Hz
	121 - 135	2500 Hz
	136 - 150	4000 Hz
	151 - 165	5000 Hz
	166 - 180	10,000 Hz
	181 - 195	15,000 Hz
	196 - 210	20,000 Hz
	211 - 225	25,000 Hz
	226 - 255	No Function

11-Channel Mode

CHANNEL	DMX VALUES	DESCRIPTION
1	000 - 255	Red , 0-100%
2	000 - 255	Green , 0-100%
3	000 - 255	Blue , 0-100%
4	000 - 255	Amber , 0-100%
5	000 - 255	Color Macros , see Colors Macros section
6	000 - 255	Color Temperature , 2400K-9900K, see Color Temperature section
7		Strobe
	000 - 031	LEDs Off
	032 - 063	LEDs On
	064 - 095	Strobe effect, slow to fast
	096 - 127	LEDs On
	128 - 159	Pulse, effect in sequences
	160 - 191	LEDs On
	192 - 223	Random strobe effect, slow to fast
	224 - 255	LEDs On
CONTINUED ON NEXT PAGE		

DMX TRAITS

11-Channel Mode (cont'd)

CHANNEL	DMX VALUES	DESCRIPTION
8	000 - 255	Dimmer Intensity , 0-100%
9	000 - 255	Dimmer Fine
10		Dim Curves
	000 - 020	Linear
	021 - 040	Square
	041 - 060	Inv. Squa
	061 - 080	S. Curve
	081 - 255	No Function
11		Refresh Rate
	000 - 015	Default
	016 - 030	900 Hz
	031 - 045	1000 Hz
	046 - 060	1100 Hz
	061 - 075	1200 Hz
	076 - 090	1300 Hz
	091 - 105	1400 Hz
	106 - 120	1500 Hz
	121 - 135	2500 Hz
	136 - 150	4000 Hz
	151 - 165	5000 Hz
	166 - 180	10,000 Hz
	181 - 195	15,000 Hz
	196 - 210	20,000 Hz
211 - 225	25,000 Hz	
226 - 255	No Function	

DMX TRAITS

12-Channel Mode

CHANNEL	DMX VALUES	DESCRIPTION
1	000 - 255	Red , 0-100%
2	000 - 255	Green , 0-100%
3	000 - 255	Blue , 0-100%
4	000 - 255	Amber , 0-100%
5	000 - 255	Color Macros , see Colors Macros section
6	000 - 255	Color Temperature , 2400K-9900K, see Color Temperature section
7		Strobe
	000 - 031	LEDs Off
	032 - 063	LEDs On
	064 - 095	Strobe effect, slow to fast
	096 - 127	LEDs On
	128 - 159	Pulse, effect in sequences
	160 - 191	LEDs On
	192 - 223	Random strobe effect, slow to fast
	224 - 255	LEDs On
8	000 - 255	Dimmer Intensity , 0-100%
9	000 - 255	Dimmer Fine
10		Dim Mode
	000 - 020	Standard
	021 - 040	Stage
	041 - 060	TV
	061 - 080	Architectural
	081 - 100	Theatre
	101 - 120	Stage 2
	121 - 140	Dim Speed, fast to slow (0.1s - 10.0s)
	141 - 255	Default

CONTINUED ON NEXT PAGE

DMX TRAITS

12-Channel Mode (cont'd)

CHANNEL	DMX VALUES	DESCRIPTION
11		<i>Dim Curves</i>
	000 - 020	Linear
	021 - 040	Square
	041 - 060	Inv. Squa
	061 - 080	S. Curve
	081 - 255	No Function
12		<i>Refresh Rate</i>
	000 - 015	Default
	016 - 030	900 Hz
	031 - 045	1000 Hz
	046 - 060	1100 Hz
	061 - 075	1200 Hz
	076 - 090	1300 Hz
	091 - 105	1400 Hz
	106 - 120	1500 Hz
	121 - 135	2500 Hz
	136 - 150	4000 Hz
	151 - 165	5000 Hz
	166 - 180	10,000 Hz
	181 - 195	15,000 Hz
	196 - 210	20,000 Hz
	211 - 225	25,000 Hz
226 - 255	No Function	

DMX TRAITS

15-Channel Mode

CHANNEL	DMX VALUES	DESCRIPTION
1	000 - 255	Red , 0-100%
2	000 - 255	Green , 0-100%
3	000 - 255	Blue , 0-100%
4	000 - 255	Amber , 0-100%
5	000 - 255	Color Macros , see Colors Macros section
6	000 - 255	Color Temperature , 2400K-9900K, see Color Temperature section
7		Strobe
	000 - 031	LEDs Off
	032 - 063	LEDs On
	064 - 095	Strobe effect, slow to fast
	096 - 127	LEDs On
	128 - 159	Pulse, effect in sequences
	160 - 191	LEDs On
	192 - 223	Random strobe effect, slow to fast
	224 - 255	LEDs On
8	000 - 255	Dimmer Intensity , 0-100%
9	000 - 255	Dimmer Fine
10		Auto Programs
	000 - 010	Off
	011 - 026	Auto Program 1
	027 - 043	Auto Program 2
	044 - 060	Auto Program 3
	061 - 076	Auto Program 4
	077 - 093	Auto Program 5
	094 - 110	Auto Program 6
	111 - 126	Auto Program 7
	127 - 143	Auto Program 8
	144 - 160	Auto Program 9
	161 - 176	Auto Program 10
177 - 193	Auto Program 11	

CONTINUED ON NEXT PAGE

DMX TRAITS

15-Channel Mode (cont'd)

CHANNEL	DMX VALUES	DESCRIPTION
10		Auto Programs (cont'd)
	194 - 210	Auto Program 12
	211 - 226	Auto Program 13
	227 - 255	No Function
11	000 - 255	Auto Programs Speed , slow to fast
12	000 - 255	Auto Programs Fade , 100% to 0%
13		Dim Mode
	000 - 020	Standard
	021 - 040	Stage
	041 - 060	TV
	061 - 080	Architectural
	081 - 100	Theatre
	101 - 120	Stage 2
	121 - 140	Dim Speed, fast to slow (0.1s - 10.0s)
	141 - 255	Default
14		Dim Curves
	000 - 020	Linear
	021 - 040	Square
	041 - 060	Inv. Squa
	061 - 080	S. Curve
	081 - 255	No Function
15		Refresh Rate
	000 - 015	Default
	016 - 030	900 Hz
	031 - 045	1000 Hz
	046 - 060	1100 Hz
	061 - 075	1200 Hz
	076 - 090	1300 Hz
	091 - 105	1400 Hz
	106 - 120	1500 Hz
121 - 135	2500 Hz	
CONTINUED ON NEXT PAGE		

DMX TRAITS

15-Channel Mode (cont'd)

CHANNEL	DMX VALUES	DESCRIPTION
15		Refresh Rate (cont'd)
	136 - 150	4000 Hz
	151 - 165	5000 Hz
	166 - 180	10,000 Hz
	181 - 195	15,000 Hz
	196 - 210	20,000 Hz
	211 - 225	25,000 Hz
	226 - 255	No Function

18-Channel Mode

CHANNEL	DMX VALUES	DESCRIPTION
1	000 - 255	Red , 0-100%
2	000 - 255	Red Fine
3	000 - 255	Green , 0-100%
4	000 - 255	Green Fine
5	000 - 255	Blue , 0-100%
6	000 - 255	Blue Fine
7	000 - 255	Amber , 0-100%
8	000 - 255	Amber Fine
9	000 - 255	Color Macros , see Color Macros section
10	000 - 255	Color Temperature , 2400K-9900K, see Color Temperature section
11		Strobe
	000 - 031	LEDs Off
	032 - 063	LEDs On
	064 - 095	Strobe effect, slow to fast
	096 - 127	LEDs On
	128 - 159	Pulse, effect in sequence
	160 - 191	LEDs On
	192 - 223	Random strobe effect, slow to fast
	224 - 255	LEDs On
12	000 - 255	Dimmer Intensity , 0-100%

CONTINUED ON NEXT PAGE

DMX TRAITS

18-Channel Mode (cont'd)

CHANNEL	DMX VALUES	DESCRIPTION
13		Auto Programs
	000 - 010	Off
	011 - 026	Auto Program 1
	027 - 043	Auto Program 2
	044 - 060	Auto Program 3
	061 - 076	Auto Program 4
	077 - 093	Auto Program 5
	094 - 110	Auto Program 6
	111 - 126	Auto Program 7
	127 - 143	Auto Program 8
	144 - 160	Auto Program 9
	161 - 176	Auto Program 10
	177 - 193	Auto Program 11
	194 - 210	Auto Program 12
	211 - 226	Auto Program 13
	227 - 255	No Function
14	000 - 255	Auto Programs Speed , slow to fast
15	000 - 255	Auto Programs Fade , 100% to 0%
16		Dim Mode
	000 - 020	Standard
	021 - 040	Stage
	041 - 060	TV
	061 - 080	Architectural
	081 - 100	Theatre
	101 - 120	Stage 2
	121 - 140	Dim Speed, fast to slow (0.1s - 10.0s)
	141 - 255	Default
CONTINUED ON NEXT PAGE		

DMX TRAITS

18-Channel Mode (cont'd)

CHANNEL	DMX VALUES	DESCRIPTION
17		<i>Dim Curves</i>
	000 - 020	Linear
	021 - 040	Square
	041 - 060	Inv. Squa
	061 - 080	S. Curve
	081 - 255	No Function
18		<i>Refresh Rate</i>
	000 - 015	Default
	016 - 030	900 Hz
	031 - 045	1000 Hz
	046 - 060	1100 Hz
	061 - 075	1200 Hz
	076 - 090	1300 Hz
	091 - 105	1400 Hz
	106 - 120	1500 Hz
	121 - 135	2500 Hz
	136 - 150	4000 Hz
	151 - 165	5000 Hz
	166 - 180	10,000 Hz
	181 - 195	15,000 Hz
	196 - 210	20,000 Hz
	211 - 225	25,000 Hz
226 - 255	No Function	

COLOR MACROS

Macro No.	DMX Value	Red	Green	Blue	W/A	Macro No.	DMX Value	Red	Green	Blue	W/A
OFF	000	0	0	0	0	34	133-136	254	177	153	0
1	001-004	80	255	234	80	35	137-140	254	192	138	0
2	005-008	80	255	164	80	36	141-144	254	165	98	0
3	009-012	77	255	112	77	37	145-148	254	121	0	0
4	013-016	117	255	83	83	38	149-152	176	17	0	0
5	017-020	160	255	77	77	39	153-156	96	0	11	0
6	021-024	223	255	83	83	40	157-160	234	139	171	0
7	025-028	255	243	77	77	41	161-164	224	5	97	0
8	029-032	255	200	74	74	42	165-168	175	77	173	0
9	033-036	255	166	77	77	43	169-172	119	130	199	0
10	037-040	255	125	74	74	44	173-176	147	164	212	0
11	041-044	255	97	77	74	45	177-180	88	2	163	0
12	045-048	255	71	77	71	46	181-184	0	38	86	0
13	049-052	255	83	134	83	47	185-188	0	142	208	0
14	053-056	255	93	182	93	48	189-192	52	148	209	0
15	057-060	255	96	236	96	49	193-196	1	134	201	0
16	061-064	238	93	255	93	50	197-200	0	145	212	0
17	065-068	196	87	255	87	51	201-204	0	121	192	0
18	069-072	150	90	255	90	52	205-208	0	129	184	0
19	073-076	100	77	255	77	53	209-212	0	83	115	0
20	077-080	77	100	255	77	54	213-216	0	97	166	0
21	081-084	67	148	255	67	55	217-220	1	100	167	0
22	085-088	77	195	255	77	56	221-224	0	40	86	0
23	089-092	77	234	255	77	57	225-228	209	219	182	0
24	093-096	158	255	144	144	58	229-232	42	165	85	0
25	097-100	255	251	153	153	59	233-236	0	46	35	0
26	101-104	255	175	147	147	60	237-240	8	107	222	0
27	105-108	255	138	186	138	61	241-244	255	0	0	0
28	109-112	255	147	251	147	62	245-248	0	255	0	0
29	113-116	151	138	255	138	63	249-252	0	0	255	0
30	117-120	99	0	255	100	64	253-255	0	0	0	255
31	121-124	138	169	255	138						
32	125-128	255	255	255	255						
33	129-132	255	206	143	0						

COLOR TEMPERATURE

Color Temp	DMX Value
No Function	000 - 015
2400K	016 - 031
2600K	032 - 047
2900K	048 - 063
3200K	064 - 079
3600K	080 - 095
3900K	096 - 111
4300K	112 - 127
4500K	128 - 143
4900K	144 - 159
5300K	160 - 175
5900K	176 - 191
6700K	192 - 207
7500K	208 - 223
8700K	224 - 239
9900K	240 - 255

DIMMER CURVES

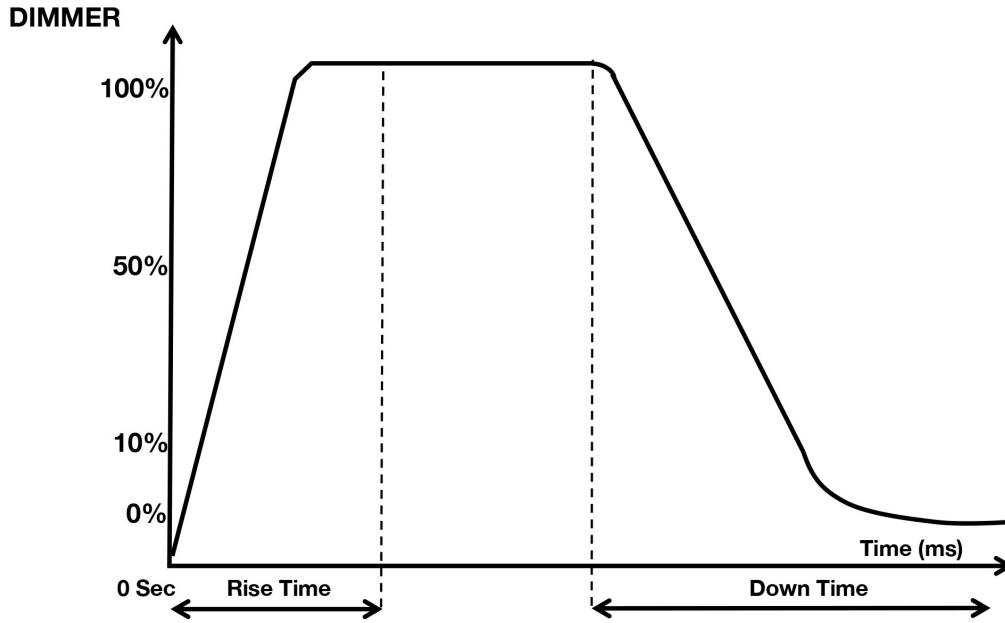

Dimming Curve Ramp Effect	0 sec Fade Time		1 sec Fade Time	
	Rise Time (ms)	Down Time (ms)	Rise Time (ms)	Down Time (ms)
Standard (default)	0	0	0	0
Stage	780	1100	1540	1660
TV	1180	1520	1860	1940
Architectural	1380	1730	2040	2120
Theatre	1580	1940	2230	2280
Stage 2	0	1100	0	1660

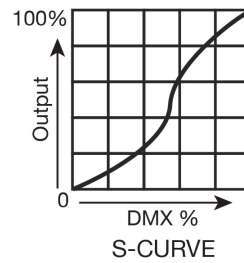
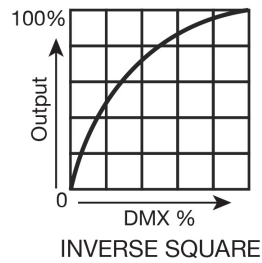
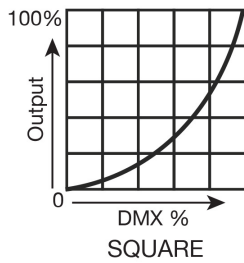
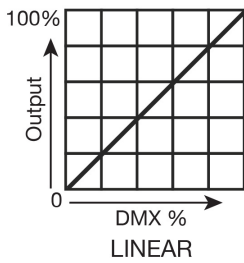

CLEANING & MAINTENANCE

WARNING! DISCONNECT UNIT FROM POWER BEFORE PERFORMING ANY CLEANING OR MAINTENANCE PROCEDURES!

ALWAYS ALLOW THE FIXTURE TO COOL FOR AT LEAST 15 MINUTES BEFORE PERFORMING ANY CLEANING OR MAINTENANCE!

CLEANING

Frequent cleaning is recommended to ensure proper function, optimized light output, and an extended life. The frequency of cleaning depends on the environment in which the fixture operates: damp, smoky, or particularly dirty environments can cause greater accumulation of dirt on the fixture's optics. Clean periodically with a soft cloth to avoid dirt/debris accumulation.

NEVER use alcohol, solvents, or ammonia-based cleaners.

MAINTENANCE

Regular inspections are recommended to ensure proper function and extended life. There are no user serviceable parts inside this fixture. Please refer all other service issues to an authorized ADJ service technician. Should you need any spare parts, please order genuine parts from an authorized ADJ dealer.

Please refer to the following points during routine inspections:

- A detailed electrical check by an approved electrical engineer every three months, to make sure the circuit contacts are in good condition and prevent overheating.
- Be sure all screws and fasteners are securely tightened at all times. Loose screws may fall out during normal operation, resulting in damage or injury as larger parts could fall.
- Check for any deformations on the housing, color lenses, rigging hardware and rigging points (ceiling, suspension, trussing). Deformations in the housing could allow for dust to enter into the fixture. Damaged rigging points or unsecured rigging could cause the fixture to fall and seriously injure a person(s).
- Electric power supply cables must not show any damage, material fatigue or sediments.

DAISY CHAIN POWER LINKAGE

This feature allows multiple flight cases to be linked together by way of the power input and output sockets. The maximum number of devices that can be connected in this manner is as follows:

- 4 flight cases using a 15-Amp plug.
- 5 flight cases using a 20-Amp plug.

After this quantity has been reached, a new power outlet must be used to accommodate additional devices.

It is recommended to leave the case lids open when charging in order to avoid the accumulation of excess heat inside the cases.

Linked devices must be of the same make and model type. **DO NOT** mix devices!

TORQUE SETTINGS

IN ORDER TO MAINTAIN THE IP65 RATING ON THE LIGHTING FIXTURES, ALL SCREWS MUST BE TIGHTENED TO THE FOLLOWING TORQUE SPECIFICATION USING A TORQUE DRIVER.

These screws must be torqued to **11.3 lb-in (13.0 kg-cm)**.

TORQUE DRIVERS (Recommended): UTICA TS-30 (shown)

ALTERNATE DRIVERS:

- Proto J6107A
- Wiha 28887



CAUTION! DO NOT OVER TORQUE SCREWS AS THIS CAN CAUSE LEAKAGE ISSUES! TO CONFIRM THE IP65 INTEGRITY AFTER A LAMP REPLACEMENT, TEST THE FIXTURE USING THE ELATION IP TESTER. CONTACT ELATION SERVICE FOR MORE DETAILS.



FUSE REPLACEMENT

The flight case features a replaceable fuse. To replace, disconnect the flight case from the power source, then use a screw driver to unscrew the fuse holder located beside the power ports. Remove the bad fuse and replace with a new one, then screw the fuse holder back in. Replace only with a new fuse of the same type and rating.

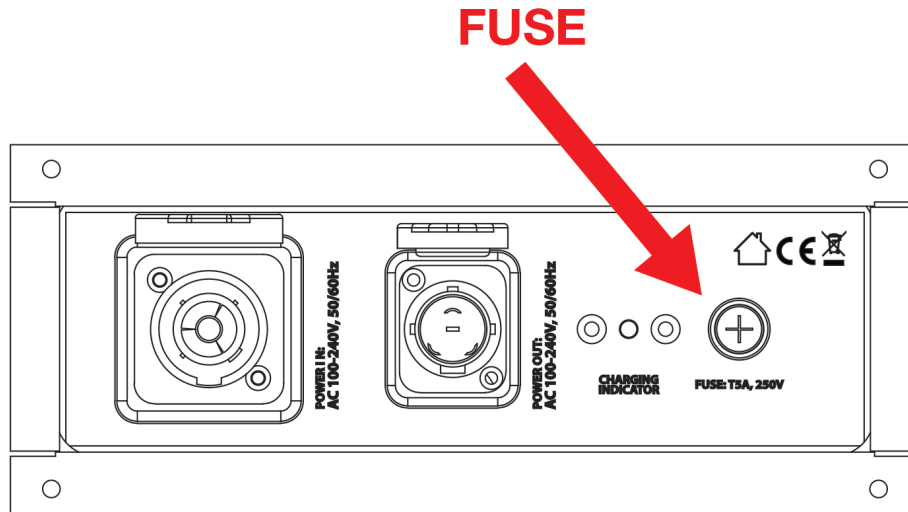

BATTERY LIFE

Following any software update, the battery life information setting must be reset before it will display accurate information. This can be done by following the steps below:

1. Navigate to Battery > Operation Mode in the system menu and make sure that the device is set to either Standard 6 or Saver 10.
2. Navigate to Battery > Current Life in the system menu.
3. Press and hold the UP button until the device flashes amber once. The device should now display an accurate battery life reading.

DIMENSIONAL DRAWINGS

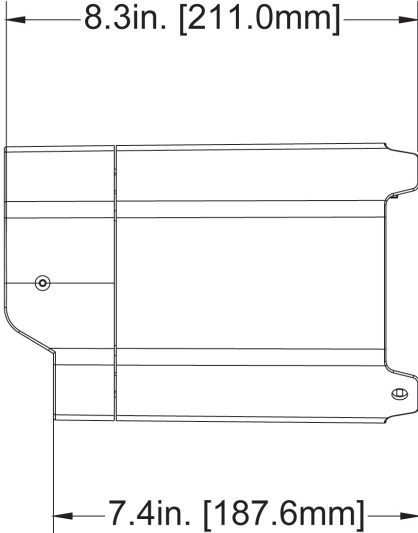
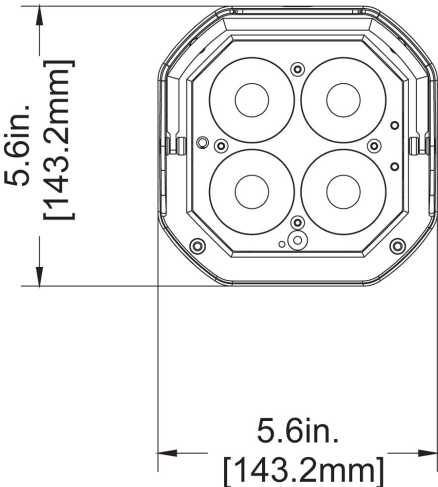
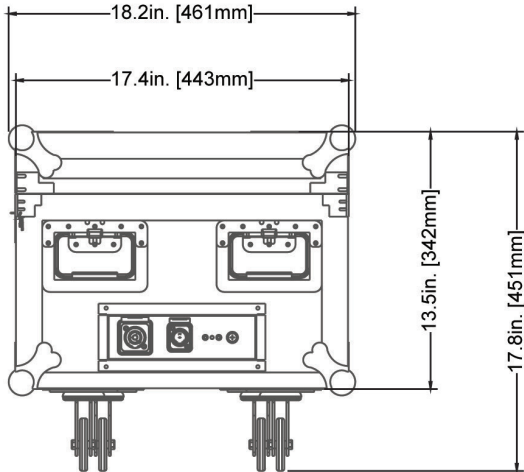
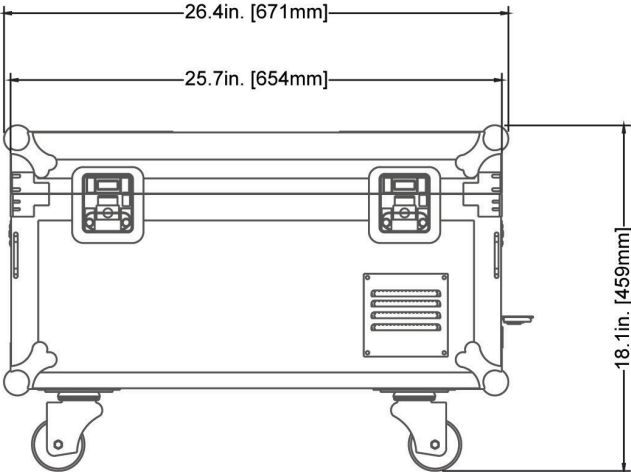

Dimensions may not be drawn to scale.

SPECIFICATIONS

MIRAGE Q6 PAK

PAK FEATURES

Houses / Transports and Charges (6) MIRAGE Q6 IP™ fixtures

PAK DIMENSIONS / WEIGHT (loaded case with 6 fixtures)

Length: 26.4" (671mm)
Width: 18.2" (461mm)
Vertical Height: 18.1" (459mm)
Loaded Weight: 97.9 lbs. (44.4 kg)

PAK ELECTRICAL / THERMAL

Power Input: AC100VAC~240VAC, 50/60Hz
IP65 Power Locking Input and Output
Max Power Consumption: 400 Watts
Power Draw: 4A
Charge status indicator
14°F to 113°F (-10°C to 45°C)

PAK INCLUDED ITEMS

(6) MIRAGE Q6 IP Fixtures
(1) MIRAGE Q6 FC Flight Case
(6) MIRAGE Q6 IPCB Charging bases and power supplies
(1) UC-IR Wireless Infrared Controller
(1) IP65 Locking Power Cable

MIRAGE Q6 IP FIXTURE

FIXTURE SOURCE

4 x 10-Watt RGBA LEDs (4-in-1 - Red, Green, Blue & Amber)
50,000 Hour Average Life*
*May vary depending on several factors including but not limited to:
Environmental Conditions, Power/Voltage, Usage Patterns (On-Off Cycling), Control, and Dimming.

PHOTOMETRIC DATA

LUX: 9903 @ 2M; 2303 @ 4M

FIXTURE OPTICS

11 Degree beam angle

FIXTURE CONTROL / CONNECTIONS:

Control protocol: WiFLY EXR DMX
11 DMX Channel modes: 4, 6, 7, 8, 9A, 9B, 10, 11, 12, 15 or 18 channels
Remote control: WiFLY EXR DMX, UC-IR (Included), Airstream IR
5 Operation modes: RGBA Dimmer Mode; Auto Run Mode (13 programs, & 1 color/fade combo mode); Static Color mode; and Wireless DMX Control
With Wired Digital Communication Network
Contact Charging system. 6x Charging bases and power supplies included in flight case

FIXTURE FEATURES:

IP65 Outdoor Rated
Built-in kickstand to angle fixture when sitting on the floor
4-touch button OLED display on rear panel
Built-in WiFLY EXR wireless DMX: Up to 2,500 feet (760M) when used with ADJ's WiFLY EXR
Battery Transceiver
64 built-in Color Macros
Variable RGBA color mixing offers a smooth, seemingly unlimited color palette - Great for Wall Washing!
LED pulse and strobe effect (0.2Hz-11Hz)
Flicker Free Operation
Electronic Dimming: 0 - 100% with 6 dim modes and 4 dim curves
Run all night - No duty cycle
Energy Save Mode
Built-in alarm system with On/Off
Battery charge indicator on each fixture
Die-cast aluminum housing

FIXTURE BATTERY

Battery Type: Fixed lithium battery
Battery Energy: 162.8WH (Watt Hours)
Battery Weight: 0.84 kg.
Battery Voltage: 14.8V
Battery Capacity: 11000mAh (Typical Capacity)
Total Lithium Ion Cells: 20 pieces
Battery Wrap Material: PVC sleeving + highland barley paper
Battery Charge Time: 7 Hours
Battery Life: 14 hours (color changing in Battery Saver Mode 14); 40 hours (single color in Battery Saver Mode 14); **Note that Battery Saver Mode 14 is available in software V1.03**

FIXTURE DIMENSIONS / WEIGHT (SINGLE UNIT)

Dimensions
Length: 5.6" (143.2mm)
Width: 5.6" (143.2mm)
Vertical Height: 8.3" (211.0mm)
Weight: 8.84 lbs. (4.01 kg.)

FIXTURE ELECTRICAL / THERMAL

Power Input: DC 17.3V
Amperage Draw: 2A
40W Max Power Consumption (each unit)
14°F to 113°F (-10°C to 45°C)

FIXTURE CERTIFICATIONS

ETL Approved (Pending)
CE Approved

INSTALLATION

Rigging: Clamps (Not Included) / Floor
Working Position: Any (360°)

Specifications subject to change without prior written notice.

