

Kramer Electronics, Ltd.



USER MANUAL

Model:

PIP-4

4 input Picture-in-Picture Inserter

Contents

1	Introduction	1
2	Getting Started	1
2.1	Quick Start	2
3	Overview	3
3.1	Recommendations for best performance	3
4	Defining the PIP-4, 4 input Picture-in-Picture Inserter	4
5	Connecting the PIP-4, 4 input Picture-in-Picture Inserter	6
5.1	Connecting a PC to the PIP-4 via RS-232 for Remote Operation	7
5.2	Connecting a PC to the PIP-4 via Ethernet for Remote Operation	7
5.2.1	Connecting the Ethernet Port Directly to a PC	7
5.2.2	Connecting the ETHERNET Port via a Network Hub	8
6	Operating the PIP-4 Locally	9
6.1	Operating the PIP-4 Using the Front Panel Buttons	9
6.1.1	Manipulating Video Panes	9
6.1.2	Navigating the OSD Menu	10
6.2	The OSD Menu	11
6.2.1	Display Submenu	11
6.2.2	Utility Submenu	11
6.3	Operating the PIP-4 Using the Mouse	12
7	Operating the PIP-4 Remotely	13
7.1	Operating the PIP-4 Using the PIP-4 Controller Software	13
7.1.1	The Menu Bar	14
7.1.2	The Quick Access Toolbar	15
7.1.3	Connecting to the Device	15
7.1.4	Windows Position	16
7.1.5	Connection Status	17
7.1.6	Changing the Layer Order	17
7.1.7	Implementing Multiple Actions At Once	17
7.1.8	Changing the Video Characteristics of a Channel	17
7.1.9	Upgrading the Firmware	18
7.1.10	Displaying the Device Details	18
7.1.11	Setting the IP Network Parameters	19
7.1.12	Displaying the PIP-4 Software Version Number	19
8	Resetting the PIP-4 Parameters to Factory Defaults	19
9	Technical Specifications	20
10	Default Communication Parameters	20
11	Communication Protocol 3000	21
11.1	Protocol 3000 Syntax	21
11.2	Command Parts Details	21

Figures

Figure 1: PIP-4 Front Panel	4
Figure 2: PIP-4 Rear Panel	5
Figure 3: Connecting the PIP-4, 4 input Picture-in-Picture Inserter	6
Figure 4: Local Area Connection Properties Window	8
Figure 5: Internet Protocol (TCP/IP) Properties Window	8
Figure 6: Video Pane Manipulation Buttons	9
Figure 7: OSD Menu Buttons	10
Figure 8: PIP-4 Controller Software Main Window	13
Figure 9: Quick Access Toolbar	15
Figure 10: Connect Window	15
Figure 11: Window Manipulation	16
Figure 12: Windows Setup Window	17
Figure 13: Device Details	18
Figure 14: About PIP-4 Controller Window	19

Tables

Table 1: PIP-4 Front Panel Features	4
Table 2: PIP-4 Rear Panel Features	5
Table 3: PIP-4 Menu Items	11
Table 4: The Display Submenu Options	11
Table 5: The Utility Submenu Options	11
Table 6: PIP-4 Controller Software Features	14
Table 7: Menu Bar Options	14
Table 8: Quick Access Toolbar Options	15
Table 9: Technical Specifications of the PIP-4, 4 input Picture-in-Picture Inserter	20
Table 10: Default Communication Parameters	20
Table 11: Instruction Codes for Protocol 3000	22

1 Introduction

Welcome to Kramer Electronics! Since 1981, Kramer Electronics has been providing a world of unique, creative, and affordable solutions to the vast range of problems that confront the video, audio, presentation, and broadcasting professional on a daily basis. In recent years, we have redesigned and upgraded most of our line, making the best even better! Our 1,000-plus different models now appear in 11 groups¹ that are clearly defined by function.

Congratulations on purchasing your Kramer **PIP-4**, *4 input Picture-in-Picture Inserter*, which is ideal for:

- Video production studios for source monitoring
- Teleconferencing using one screen
- Home theater multi-channel monitoring
- Security applications

The package includes the following items:

- **PIP-4**, 4 input Picture-in-Picture Inserter
- **RC-IR3** *Infrared Remote Controller* (including batteries and manual²)
- Power adapter (5V DC output)
- This user manual²

2 Getting Started

We recommend that you:

- Unpack the equipment carefully and save the original box and packaging materials for possible future shipment
- Review the contents of this user manual

¹ GROUP 1: Distribution Amplifiers; GROUP 2: Switchers and Matrix Switchers; GROUP 3: Control Systems; GROUP 4: Format/Standards Converters; GROUP 5: Range Extenders and Repeaters; GROUP 6: Specialty AV Products; GROUP 7: Scan Converters and Scalers; GROUP 8: Cables and Connectors; GROUP 9: Room Connectivity; GROUP 10: Accessories and Rack Adapters; GROUP 11: Sierra Products

² Download up-to-date Kramer user manuals from <http://www.kramerelectronics.com>

2.1 Quick Start

The following quick start chart summarizes the basic setup and operation steps for the PIP-4.

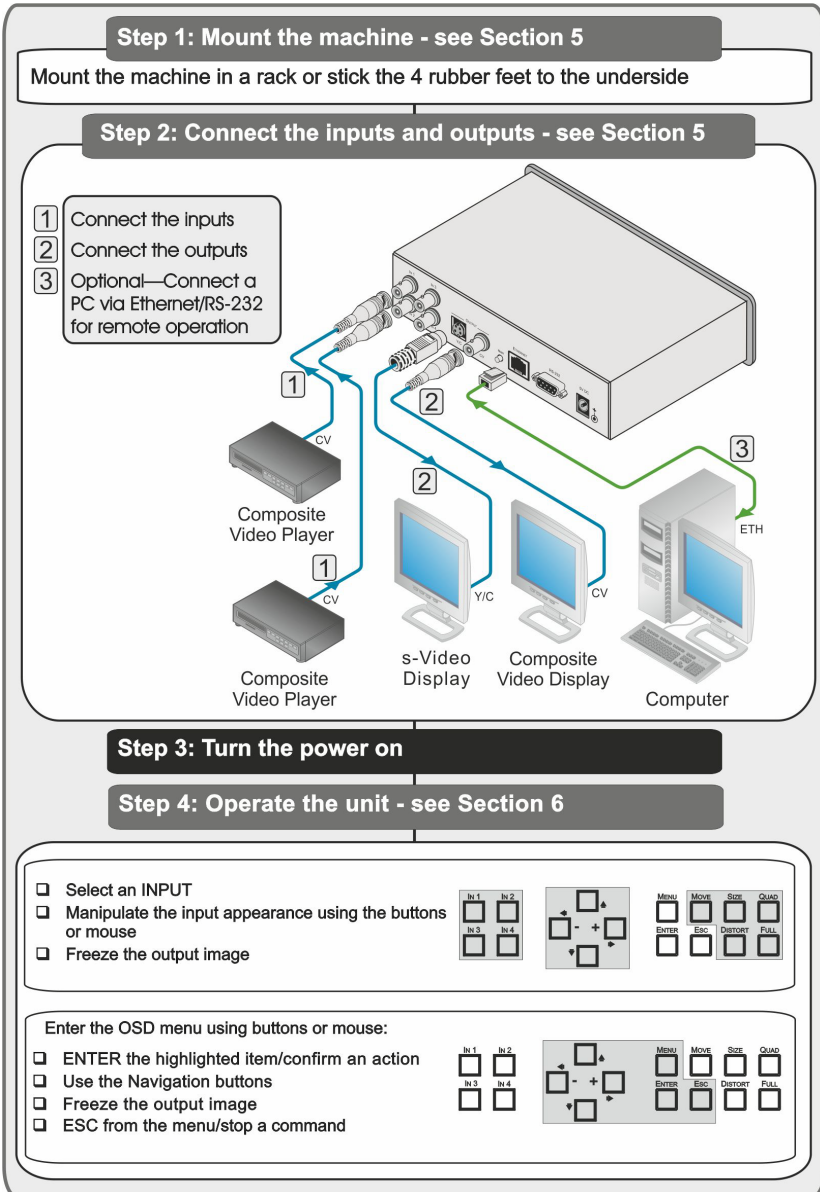

3 Overview

The high performance Kramer desktop **PIP-4** is a picture-in-picture inserter for composite video signals.

The **PIP-4** features:

- A multi-standard, picture-in-picture video inserter that accepts up to four composite video sources and displays them all on the same screen simultaneously
- s-Video and composite video outputs
- Non-volatile memory that retains the last setting¹

With the **PIP-4**, you can:

- Position sources on the screen as desired and select their size dynamically using a mouse or by selection from a list
- Freeze the output
- Output video as both s-Video and composite signals

In addition, the **PIP-4**:

- Includes 10-bit video A/D and D/A converters throughout the unit, ensuring the highest quality video
- Can be operated locally via:
 - The front panel buttons
 - A user-friendly OSD (On-Screen Display) menu
- Can be operated remotely via an IR remote controller, RS-232 and Ethernet
- Is rugged and dependable

3.1 Recommendations for best performance

To achieve the best performance:

- Connect only good quality connection cables² thus avoiding interference, deterioration in signal quality due to poor matching, and elevated noise levels (often associated with low quality cables)
- Avoid interference from neighboring electrical appliances and position your **PIP-4** away from moisture, excessive sunlight and dust

	Caution: No operator serviceable parts inside unit
	Warning: Use only the Kramer Electronics input power wall adapter that is provided with the unit
	Warning: Disconnect power and unplug unit from wall before installing or removing the device or servicing unit

¹ Provided the last setting was valid for at least 30 seconds before switching the machine off

² The complete list of Kramer cables is available from <http://www.kramerelectronics.com>

4 Defining the PIP-4, 4 input Picture-in-Picture Inserter

Figure 1 and Table 1 define the front panel of the **PIP-4, 4 input Picture-in-Picture Inserter**.

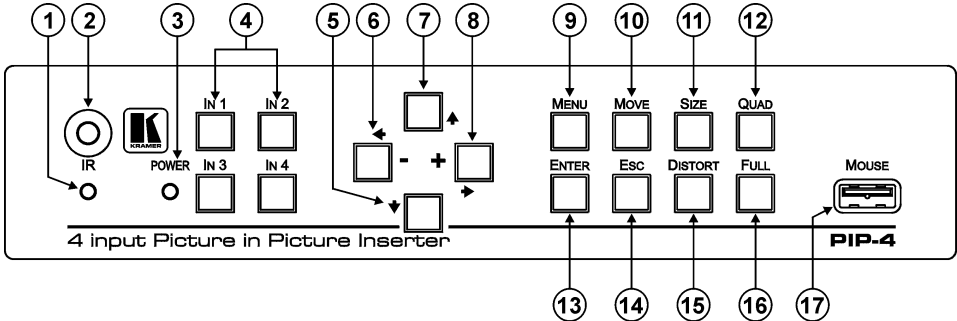

Figure 1: PIP-4 Front Panel

Table 1: PIP-4 Front Panel Features

#	Feature	Function	
1	IR LED	Lights yellow when the unit receives IR signals	
2	IR Sensor	IR signal receiver	
3	POWER LED	Lights green when the unit is powered on	
4	IN 1	Input Selector Buttons	Press to select input 1
	IN 2		Press to select input 2
	IN 3		Press to select input 3
	IN 4		Press to select input 4
5	Navigation Buttons	Navigation Buttons	In MOVE mode, moves the selected pane down. In SIZE mode, shrinks the selected pane. In DISTORT mode, moves the bottom of the pane down. In the OSD menu, moves the cursor down one option
			In MOVE mode, moves the selected pane left. When in SIZE mode, shrinks the selected pane. In DISTORT mode, moves the right hand side of the selected pane to the left. In the OSD menu, moves the cursor to the left
			In MOVE mode, moves the selected pane up. In SIZE mode, expands the selected pane. In DISTORT mode, moves the bottom of the pane up. In the OSD menu, moves the cursor up one option
			In MOVE mode, moves the selected pane right. When in SIZE mode, expands the selected pane. In DISTORT mode, moves the right hand side of the selected pane to the right. In the OSD menu, moves the cursor to the right
9	MENU Button	Press to display the OSD menu. Press again to exit the OSD menu	
10	MOVE Button	Moves the active pane. Press to enter the MOVE mode followed by one of the arrow buttons	
11	SIZE Button	Resizes the active pane while retaining the aspect ratio. Press to enter the SIZE mode followed by one of the arrow buttons	
12	QUAD Button	Press to display all 4 inputs in equally sized panes	

Defining the PIP-4, 4 input Picture-in-Picture Inserter

#	Feature	Function
13	ENTER Button	When in the OSD menu, press to select the current option or to confirm an action
14	ESC Button	Exits the OSD Menu
15	DISTORT Button	Distorts the active pane by changing the aspect ratio. Press to enter the DISTORT mode followed by one of the arrow buttons
16	FULL Button	Expands the active pane to full screen
17	MOUSE USB Connector	Connect USB/PS/2 mouse for operating the OSD menu

[Figure 2](#) and [Table 2](#) define the rear panel of the **PIP-4, 4 input Picture-in-Picture Inserter**.

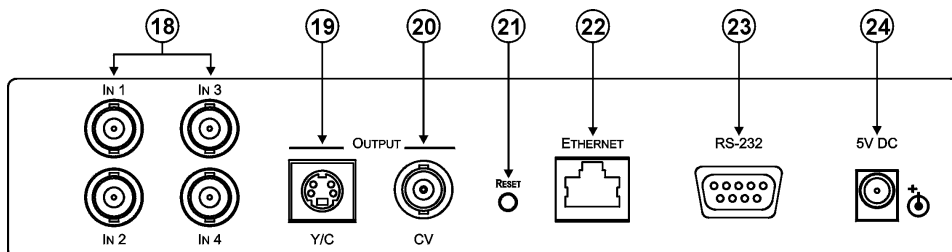

Figure 2: PIP-4 Rear Panel

Table 2: PIP-4 Rear Panel Features

#	Feature	Function	
18	IN 1	Composite Video BNC Input Connectors	Connect to composite video source 1
	IN 2		Connect to composite video source 2
	IN 3		Connect to composite video source 3
	IN 4		Connect to composite video source 4
19	OUTPUT	Y/C 4-pin s-Video Output Connector	Connect to the s-Video acceptor
20		CV BNC Output Connector	Connect to the composite video acceptor
21	RESET Button	Press and hold while switching the unit on to reset all parameters to factory default values (see Section 8)	
22	ETHERNET RJ-45 Connector	Connect to LAN for remote operation using a PC	
23	RS-232 9-pin D-sub Connector	Connect to a PC or other device for remote operation	
24	5V DC Power Connector	Connect to supplied power adapter, center pin positive	

5 Connecting the PIP-4, 4 input Picture-in-Picture Inserter

To connect¹ the PIP-4 as illustrated in the example in [Figure 3](#):

1. Connect a composite video player source to the IN 1 BNC connector².
2. Connect a composite video player source to the IN 2 BNC connector².
3. Connect an s-Video display acceptor to the Y/C OUTPUT 4-pin s-Video connector³.
4. Connect a composite video display acceptor to the CV OUTPUT BNC connector³.
5. Optional—for remote operation, connect the ETHERNET RJ-45 connector to a LAN to which the PC is connected (see [Section 5.2.2](#))⁴.
6. Connect the supplied power adapter to the unit and to the mains supply (not shown in [Figure 3](#)).

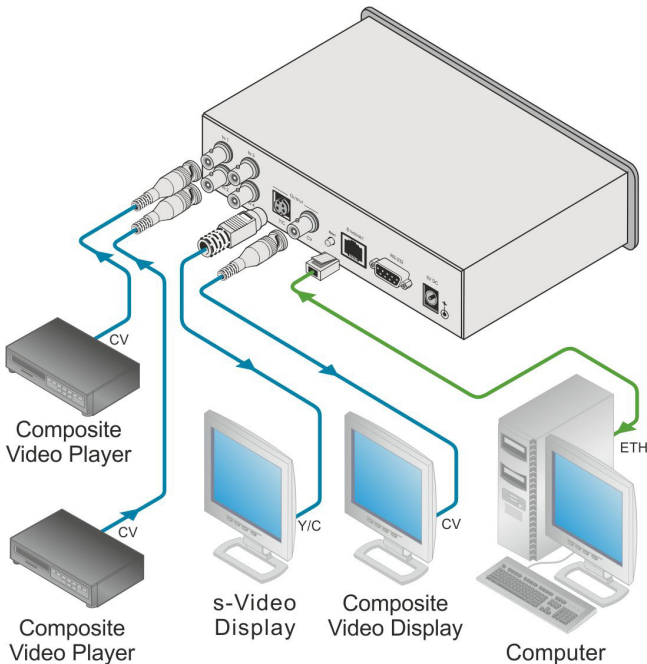

Figure 3: Connecting the PIP-4, 4 input Picture-in-Picture Inserter

1 Switch off the power on each device before connecting it to your PIP-4. After connecting your PIP-4, switch on its power and then switch on the power to each device

2 The device supports up to 4 simultaneous inputs

3 You do not have to connect both outputs

4 The device can also be operated remotely via the RS-232 port

5.1 Connecting a PC to the PIP-4 via RS-232 for Remote Operation

You can connect to the **PIP-4** via an RS-232 connection using, for example, a PC. Note that a null-modem adapter/connection is not required.

To connect to the **PIP-4** via RS-232:

- Connect the RS-232 9-pin D-sub rear panel port on the **PIP-4** unit via a 9-wire straight cable (only pin 2 to pin 2, pin 3 to pin 3, and pin 5 to pin 5 need to be connected) to the RS-232 9-pin D-sub port on your PC

5.2 Connecting a PC to the PIP-4 via Ethernet for Remote Operation

You can connect to the **PIP-4** via Ethernet using either of the following methods:

- Direct connection to the PC using a crossover cable (see [Section 5.2.1](#))
- Connection via a network hub, switch, or router, using a straight-through cable (see [Section 5.2.2](#))

5.2.1 Connecting the Ethernet Port Directly to a PC

You can connect the Ethernet port of the **PIP-4** to the Ethernet port on your PC, via a crossover cable with RJ-45 connectors.

This type of connection is recommended for identifying the PIP-4 with the factory configured default IP address

To connect directly to your PC and to configure it:

1. Using a crossover cable, connect the unit directly to your PC.
2. Right-click the **My Network Places** icon on your desktop.
3. Select **Properties**.
4. Right-click Local Area Connection Properties.
5. Select **Properties**.
The Local Area Connection Properties window appears.
6. Select the Internet Protocol (TCP/IP) and click the **Properties** Button (see [Figure 4](#)).

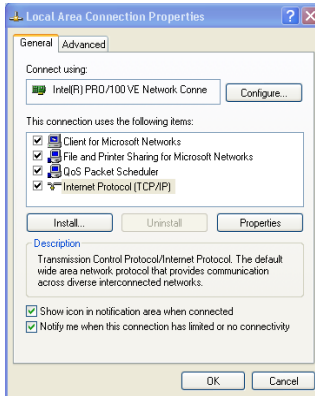

Figure 4: Local Area Connection Properties Window

7. Select Use the following IP Address, and fill in the details as shown in [Figure 5](#).
8. Click **OK**.

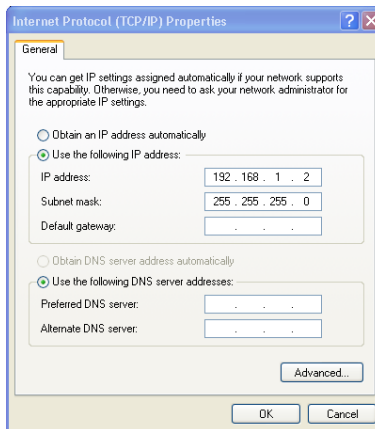

Figure 5: Internet Protocol (TCP/IP) Properties Window

5.2.2 Connecting the ETHERNET Port via a Network Hub

You can connect the Ethernet port of the **PIP-4** to the Ethernet port on a network hub or network router, via a straight-through cable with RJ-45 connectors.

6 Operating the PIP-4 Locally

You can operate your **PIP-4** locally via:

- The front panel buttons (see [Section 6.1](#))
- A mouse (see [Section 6.3](#))
- An IR remote controller

6.1 Operating the PIP-4 Using the Front Panel Buttons

The front panel buttons are used to:

- Manipulate video panes
- Navigate the OSD menu

Note: If there is no mouse activity for 20 seconds, the OSD closes automatically.

6.1.1 Manipulating Video Panes

You can use the front panel buttons (displayed within gray boxes in [Figure 6](#)) to manipulate the display (such as, changing size and aspect ratio) of each of the four inputs independently.

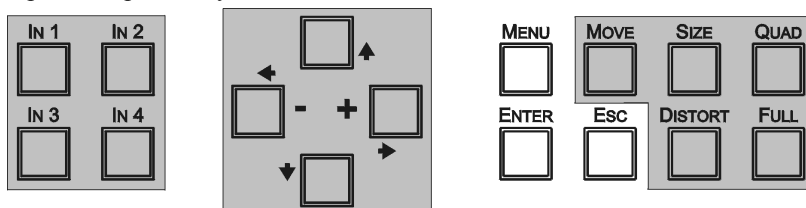

Figure 6: Video Pane Manipulation Buttons

The buttons operate in the following manner:

- IN 1 to IN 4: Select the input to manipulate
- \uparrow , \downarrow , \leftarrow , \rightarrow : Move up, down, left/decrease and right/increase
- Move, Size, Quad, Distort and Full: Select an operation to perform on the pane

Example

To increase the size of the Input 3 window:

1. Press IN 3.
The Input 3 window becomes active. Its outline becomes black and flashes.
2. Press SIZE.
Size is displayed in the Input 3 pane.
3. Repeatedly press or press and hold the \rightarrow + button until the window is the required size.
4. Press ESC.

6.1.2 Navigating the OSD Menu

You can use the front panel OSD menu buttons (see [Figure 7](#)) to navigate the OSD in order to modify the video parameters (such as brightness and contrast) of each input independently.

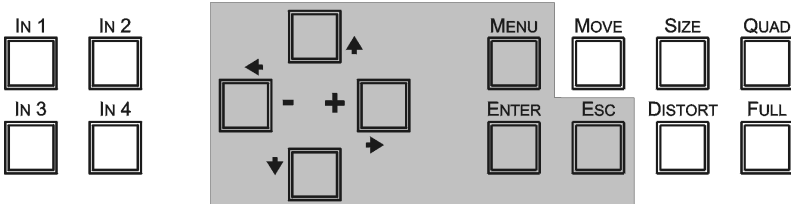

Figure 7: OSD Menu Buttons

The buttons operate in the following manner:

- MENU: Display the OSD¹. Press again to exit the OSD from any level
- ENTER: Enter a menu item or accept a parameter value
- +, - : Increase/decrease a parameter value
- ▲, ▼, ◀, ▶: Navigate through the menu items
- ESC: Exit the OSD menu, a menu item or parameter value

Note: If there is no mouse activity for 20 seconds, the OSD closes automatically.

Example

To vertically mirror the Input 3 pane:

1. Press IN 3.
The Input 3 window becomes active. Its outline becomes black and starts to flash.
2. Press MENU.
The OSD is displayed and Display is highlighted.
3. Press ▶.
The cursor moves to Screen.
4. Press ▼.
Source is highlighted.
5. Press ENTER.
The Source Setup screen is displayed.
6. Check the Mirror V box.
7. Click on the X to close the OSD.

¹ The menu times-out after 20 seconds

6.2 The OSD Menu

The OSD menu provides access to the PIP-4 configuration. Using the OSD menu you can change the general display and individual input settings.

Table 3: PIP-4 Menu Items

Menu Item	Submenu	Description
DISPLAY	Quad Full	Selects all 4 inputs to display
	Source	Sets each input video pane's characteristics
	Zoom	Zooms the center of the selected pane to double size
	Overscan/Normal	Selects whether to display in normal or overscan mode
UTILITY	Brightness	Sets the brightness of each input video signal
	Contrast	Sets the contrast of each input video signal
	Sharpness	Sets the sharpness of each input video signal
	Hue	Sets the hue of each input video signal
	Color	Sets the color of each input video signal
Store		Stores the current setting in one of the 10 presets
Recall		Recalls one of the 10 presets
Erase		Erases one of the 10 presets

6.2.1 Display Submenu

[Table 4](#) defines the Display submenu features.

Table 4: The Display Submenu Options

Item	Parameter	Values
Full/Quad	Not applicable	Full/Quad
Source	Window	0-3
	Source video	0-3
	Mirror V	On/Off
	Mirror H	On/Off
	Freeze	On/Off
	Blank	On/Off
Zoom	Not applicable	On/Off
Overscan/Normal	Not applicable	Overscan/Normal

6.2.2 Utility Submenu

[Table 5](#) defines the utility submenu.

Table 5: The Utility Submenu Options

Item	Parameter	Values
Brightness	Channel	1-4
	Brightness	1-255
Contrast	Channel	1-4
	Contrast	1-255
Sharpness	Channel	1-4
	Sharpness	0-15

Item	Parameter	Values
Hue	Channel	1-4
	Hue	1-255
Color	Channel	1-4
	Color	1-255

6.3 Operating the PIP-4 Using the Mouse

The mouse control operates in the following manner:

- Left-click on a pane to select it
- Click and hold within a pane, and drag to move it
- Click and hold on the border of a pan, and drag to change the size and aspect ratio of the pane. Dragging the border of a pane over the opposite border of the pane flips the pane over (mirrors the pane)
- Right click anywhere to display the OSD Menu
 - In the OSD Menu, left click to navigate the OSD and modify parameters

Note: If there is no mouse activity for 20 seconds, the OSD closes automatically.

Example

To change the brightness of Input 2:

1. Left-click on the input 2 pane.
2. Right-click to display the OSD.
3. Use the mouse to navigate to Utility > Brightness.
4. Left-click on Brightness.
The Brightness parameter setting is displayed.
5. Modify the setting to the required value using the Brightness left and right arrows.
6. Click on the X to close the OSD.

Example

To vertically mirror the Input 3 pane:

1. Right-click to display the OSD.
2. Use the mouse to navigate to Display > Source.
3. Click on the Source Video right arrow to select Input 3.
4. Click Mirror V.
5. Click on the X to close the OSD.

7 Operating the PIP-4 Remotely

You can operate your **PIP-4** remotely via the following:

- IR remote controller
- Ethernet over a LAN
- RS-232 serial commands transmitted by a touch screen system, PC, or other serial controller

7.1 Operating the PIP-4 Using the PIP-4 Controller Software

The **PIP-4** Control application¹ is used to control the device via either RS-232 or Ethernet.

For details regarding connecting to the Ethernet port on the **PIP-4**, see [Section 5.2](#).

The Controller software requires the following:

- Windows™ XP, Vista or Windows™ 7
- Microsoft .Net Framework version 3.5

To install the Controller software, download the software and run the setup file. After installation, running the Controller software for the first time displays a window similar to that shown in [Figure 8](#).

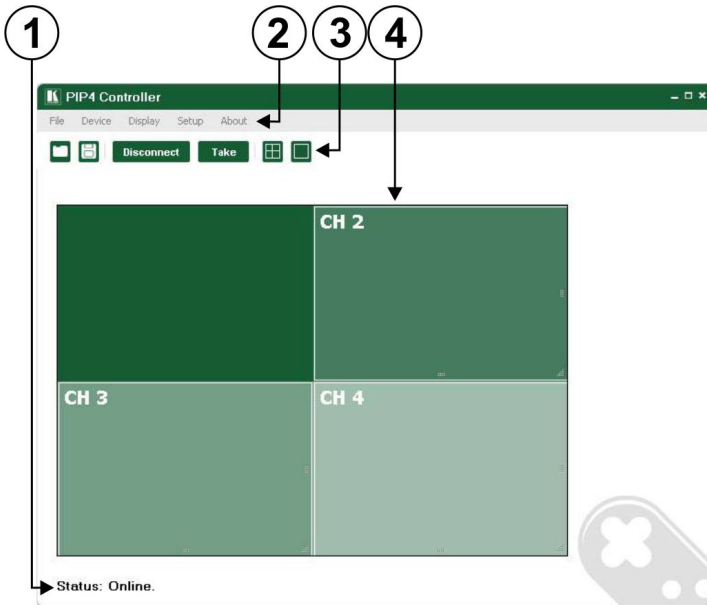

Figure 8: PIP-4 Controller Software Main Window

¹ Download the application from <http://www.kramerelectronics.com>

Table 6: PIP-4 Controller Software Features

#	Feature	Function
1	Status Indicator	Indicates whether the controller software is online, online in Take mode, offline, or offline in Take mode
2	Menu Bar	Operate and configure the device using the Menu Bar options (see Section 7.1.1)
3	Quick Access Toolbar	Operate and configure the device using the quick access toolbar buttons (see Section 7.1.2)
4	Window Position	Modify window size and position by dragging and dropping individual windows (see Section 7.1.4)

Note: Unless the device is in off-line mode (set by pressing the **Take** button), when a change is made on the device (for example, a different output is selected), the change is reflected almost immediately in the main window of the Controller Software. Similarly, if a change is made in the Controller Software, the change is reflected almost immediately on the device.

7.1.1 The Menu Bar

The menu bar options are shown in [Table 7](#).

Table 7: Menu Bar Options

Menu Bar Options	Sub Menu	Description
FILE	<i>Open</i>	Open an existing configuration
	<i>Save</i>	Save the current configuration
	<i>Exit</i>	Exit the PIP-4 Controller software
DEVICE	<i>Connect/Disconnect</i>	Connect or disconnect to the device (see Section 7.1.3)
	<i>Take/Update</i>	Press Take to put the device in off-line mode. Press Update to implement waiting changes and return the device to on-line mode (see Section 7.1.7)
	<i>Device Details</i>	Retrieve, display and edit the device details, such as, model, unit name, version, etc. See Section 7.1.10
	<i>Firmware Update</i>	Update the device firmware
DISPLAY	<i>Quad</i>	Set the screen to display the quad 4-window configuration
	<i>Full</i>	Set the screen to display the single-window configuration
	<i>Zoom</i>	Enlarges and displays a movable region as a full screen
	<i>Refresh</i>	Retrieve all information from the device
SETUP	<i>Effects</i>	Sets the following signal characteristics for each input: Brightness, Contrast, Sharpness, Hue and Color
	<i>Source</i>	Sets the following source characteristics: Select Channel, Connect to Video Source, Mirror V, Mirror H, Freeze and Blank
	<i>Turn Overscan On</i>	Turns on overscan
	<i>Store</i>	Stores the current video configuration in one of 10 preset memories
	<i>Recall</i>	Recalls the video configuration from one of 10 preset memories
	<i>Erase</i>	Erases the video configuration from one of the 10 preset memories
ABOUT	Displays the Step-in Software and Kramer company details	









7.1.2 The Quick Access Toolbar

The Quick Access Toolbar buttons are shown in [Figure 9](#) and described in [Table 8](#).



Figure 9: Quick Access Toolbar

Table 8: Quick Access Toolbar Options

Feature	Description
	Open an existing configuration
	Save the current configuration
 	Connects to and disconnects from the device (see Section 7.1.3)
 	Press Take to enable multiple off-line changes to be made. Press Update to implement the changes (see Section 7.1.7)
	Set the screen to display the quad 4-window configuration
	Set the screen to display the single-window configuration

7.1.3 Connecting to the Device

To connect to the device:

1. Click the **Connect** button.

The window shown in [Figure 10](#) appears.

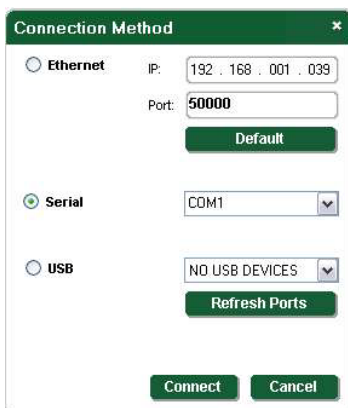

Figure 10: Connect Window

2. Select the required method of connection option button:
 - For Ethernet, enter the IP address and Port number of the device. To set the default IP address and Port number, press the **Default** button.
 - For a serial connection, select the required Com port from the drop-down list.
 - For a USB connection¹, select the required USB device from the drop-down menu.
If necessary, click **Refresh Ports** to update the USB port list.
3. Click **Connect**.
If the connection is successful, the main window shown in [Figure 8](#) appears.
If the connection is not successful, a Timeout error message appears.

7.1.4 Windows Position

The windows can be manually manipulated in size and position.

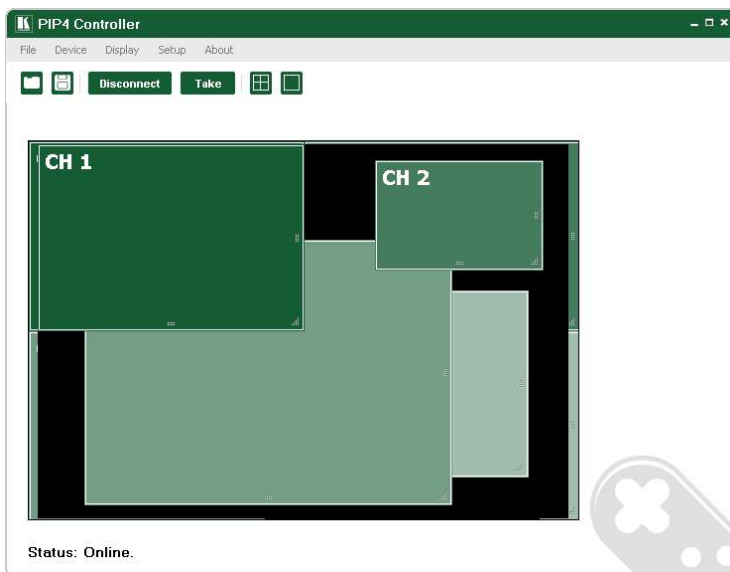

Figure 11: Window Manipulation

To change the size of a window:

- Click, hold and drag the required window handle at the right hand side, bottom, or bottom right hand corner of the window

To change the position of a window:

- Click, hold and drag anywhere in the window

¹ At the time of printing this option is not available

7.1.5 Connection Status

The connection status can be one of the following states:

- Online—the device is connected and being updated in real-time by the software
- Online, in take mode (not updating device)—the device is connected but changes are only implemented when the Update button is pressed
- Offline—in Take mode
- Offline—the device is not connected

7.1.6 Changing the Layer Order

You can change the order in which the windows are arranged simply by clicking on a window to raise it to the top.

7.1.7 Implementing Multiple Actions At Once

To implement multiple actions at once:

1. Press the **Take** button to put the device in off-line mode.
The button changes to the **Update** button and the device is in off-line mode.
2. Perform the required actions, such as, switching and layer order changes.
3. Press the **Update** button.
The button changes to the **Take** button and all changes are implemented.

7.1.8 Changing the Video Characteristics of a Channel

To change the video characteristics of a channel:

1. Click **Setup > Effects**.
The Display Effects window appears as shown in [Figure 12](#).

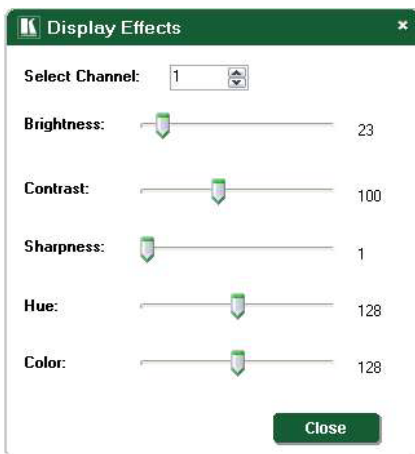

Figure 12: Windows Setup Window

2. Click and hold on the slider, dragging it to modify the required characteristic. For fine control of the slider, use the arrow buttons on your keyboard.
3. Click **Close**.
The channel video characteristic is changed.

7.1.9 Upgrading the Firmware

To upgrade the firmware:

1. Download the latest firmware file from <http://www.kramerelectronics.com>.
2. Click **Device > Firmware Upgrade**.
3. Browse to the firmware file that you downloaded.
4. Click **Open**.

The current firmware version is checked and if this is older than the downloaded firmware, the downloaded firmware is installed.

Note: Do not interrupt the uploading process or the device may be damaged.

5. Ignore the reset message and when the process is complete, reset the device by disconnecting the power and then reconnecting it.

7.1.10 Displaying the Device Details

To display the device details:

1. Click **Device > Device Details**.
The device details are displayed, such as, model and serial number as shown in [Figure 13](#).

The screenshot shows a window titled "Device Details" with a green header bar. The window is divided into two main sections: "Unit Info" and "Connectivity".

Unit Info:

Property	Value
Model	PIP-4
Unit Name	KRAMER_0000
Unit Version	00.09.00.5445
Serial Number	0

A "Set Value" button is located to the right of the Unit Name and Unit Version fields.

Connectivity:

Property	Value
Ip Address	192.168.001.039
Mac Address	00-20-4a-86-27-22

A "Set Value" button is located to the right of the Ip Address field.

A "Close" button is located at the bottom right of the window.

Figure 13: Device Details

7.1.11 Setting the IP Network Parameters

To set the IP network parameters:

1. Click **Device > Device Details**.
2. Under **Connectivity**, edit the required parameter(s).
3. Click **Set Value**.
A confirmation message appears.
4. Click **OK**.
The parameter is set.
5. Reboot the device.

7.1.12 Displaying the PIP-4 Software Version Number

To display the PIP-4 Software version number:

1. From the Menu bar, click **About**.
The **About PIP-4 Controller** window appears as shown in [Figure 14](#).



Figure 14: About PIP-4 Controller Window

2. Click **OK** to close the window.

8 Resetting the PIP-4 Parameters to Factory Defaults

For a list of the factory default parameters see [Section 10](#).

To reset all parameters to factory default values:

1. Disconnect the power from the device.
2. Press and hold the Reset button on the rear panel of the unit.
3. While holding the Reset button, reconnect the power to the device.
4. Wait until the video pane(s) are displayed. Release the Reset button.
The parameters are reset to factory default values.

9 Technical Specifications

[Table 9](#) lists the technical specifications¹ of the **PIP-4, 4 input Picture-in-Picture Inserter**.

Table 9: Technical Specifications² of the PIP-4, 4 input Picture-in-Picture Inserter

INPUTS:	4 composite video 1Vpp @75Ω on BNC connectors
OUTPUTS:	1 s-Video 1Vpp, 0.3Vpp @75Ω on a 4-pin s-Video connector 1 composite video 1Vpp @75Ω on a BNC connector
DIGITAL RESOLUTION:	10 bit
S/N RATIO:	60db (weighted)
YC SEPARATION:	Adaptive 4-line digital comb filters
MEMORY:	Non-volatile memory for storage of 2 setups
CONTROL:	Front-panel, OSD, RS-232 and Ethernet
POWER SOURCE:	5V DC, 450mA
OPERATING TEMPERATURE:	0° to +55°C (32° to 131°F)
STORAGE TEMPERATURE:	-45° to +72°C (-49° to 162°F)
HUMIDITY:	10% to 90%, RHL non-condensing
DIMENSIONS:	21.5cm x 17.7cm x 4.4cm (8.5" x 7" x 1.7") W, D, H
WEIGHT:	0.8kg (1.76lbs) approx.
ACCESSORIES:	Power Supply, RC-IR3 Infrared Remote Control
OPTIONS:	RK-1 rack adapter

10 Default Communication Parameters

Table 10: Default Communication Parameters

Protocol 3000 (Default)	
Baud Rate:	115,200
Data Bits:	8
Stop Bits:	1
Parity:	None
Command Format:	ASCII
Example (Output 1 to Input 1):	#AV 1>1<CR>
Ethernet	
Default Settings	Reset Settings
IP Address: 192.168.1.39	Power cycle the unit while holding in the Factory Reset button, located on the rear panel of the unit
Subnet Mask:	
Gateway:	
TCP Port #: 5000	
UDP Port #: 50000	

¹ Measurements relate to composite video, unless otherwise stated

² Specifications are subject to change without notice

11 Communication Protocol 3000

The Protocol 3000¹ is an RS-232/Ethernet communication protocol that enables you to control the device from any standard terminal software (for example, Windows® HyperTerminal Application).

11.1 Protocol 3000 Syntax

Host message format:

Start	Address (optional)	Body	Delimiter
#	<i>Destination_id@</i>	message	CR

Simple command (commands string with only one command without addressing):

start	body	delimiter
#	Command SP Parameter_1,Parameter_2,...	CR

Commands string (formal syntax with commands concatenation and addressing):

Address@ **Command_1** *Parameter1_1,Parameter1_2,...* | **Command_2** *Parameter2_1,Parameter2_2,...* | **Command_3** *Parameter3_1,Parameter3_2,...* | ... **CR**

Device message format:

Start	Address (optional)	Body	Delimiter
~	<i>Sender_id@</i>	message	CR LF

Device long response (**Echoing command**):

Start	Address (optional)	Body	Delimiter
~	<i>Sender_id@</i>	command SP [<i>param1 ,param2 ...</i>] result	CR LF

CR = Carriage return (ASCII 13 = 0x0D)

LF = Line feed (ASCII 10 = 0x0A)

SP = Space (ASCII 32 = 0x20)

11.2 Command Parts Details

Command:

Sequence of ASCII letters ('A'-'Z', 'a'-'z' and '-').

Command will separate from parameters with at least single space.

Parameters:

Sequence of Alfa-Numeric ASCII chars ('0'-'9','A'-'Z','a'-'z' and some special chars for specific commands), parameters will be separated by commas.

Message string:

Every command must to be entered as part of message string that begin with **message starting char** and end with **message closing char**, note that string can contain more then one command separated by pipe ("|") char.

Message starting char:

'#' for host command/query.

'~' for machine response.

Device address (Optional, for Knet):

Knet Device ID follow by '@' char.

Query sign = "?", will follow after some commands to define query request.

Message closing char =

Host messages - Carriage Return (ASCII 13), will be referred to by **CR** in this document.

Machine messages - Carriage Return (ASCII 13) + Line-Feed (ASCII 10), will be referred to by **CRLF**.

Spaces between parameters or command parts will be ignored.

Commands chain separator char:

When **message string** contains more than one command, commands will be separated by pipe ("|").

Commands entering:

If terminal software used to connect over serial \ ethernet \ USB port, that possible to directly enter all commands characters (**CR** will be entered by Enter key, that key send also **LF**) but this char will be ignored by commands parser.

Sending commands from some controllers (like Crestron) require coding some characters in special form (like \X##). Anyway, there is a way to enter all ASCII characters, so it is possible to send all commands also from controller.

(Similar way can use for URL \ Telnet support that maybe will be added in future).

Commands forms:

Some commands have short name syntax beside the full name to allow faster typing, response is always in long syntax.

Commands chaining:

It is possible to enter multiple commands in same string by '|' char (pipe).

In this case the **message starting char** and the **message closing char** will be entered just one time, in the string beginning and at the end.

All the commands in string will not execute until the closing char will be entered.

Separate response will be sent for every command in the chain.

Input string max length:

64 characters.

Backward support:

Design note: transparent supporting for protocol 2000 will be implemented by switch protocol command from protocol 3000 to protocol 2000, in protocol 2000 there is already such a command to switch protocol to ASCII protocol (#56 : H38 H80 H83 H81).

Table 11: Instruction Codes for Protocol 3000

Result Codes	
	Syntax
No error. Command running succeeded	COMMAND PARAMETERS OK
Protocol Errors	
Syntax Error	ERR001
Command not available for this device	ERR002
Parameter is out of range	ERR003
Unauthorized access (running command without the match login).	ERR004

Help commands		
Command	Syntax	Response
Protocol Handshaking	#CR	~OKCRLF

Device initiated messages	
Command	Syntax
Start message	~Protocol Start

Set/Get coordinate	#CRDT <u>win_num</u> ,x0,y0,x1,y1<CR> (win_num = 1-4; x0,y0 - top-left coordinate; x1,y1 - bottom-right coordinate) #CRDT? <u>win_num</u> <CR> (x0,x1 <=180; y0,y1 <=144(for PAL); y0,y1 <= 120(for NTSC)) (win_num = 1-4 or 0(for output window))
---------------------------	--

Set/Get Brightness / Contrast / Sharpness / Hue / Color	#BRIGHTNESS <input type="text"/> <input type="text"/> <CR> (vol = 1-255) #BRIGHTNESS? <input type="text"/> <CR> #CONTRAST <input type="text"/> <input type="text"/> <CR> (vol = 1-255) #CONTRAST? <input type="text"/> <CR> #SHARPNESS <input type="text"/> <input type="text"/> <CR> (vol = 0-15) #SHARPNESS? <input type="text"/> <CR> #HUE <input type="text"/> <input type="text"/> <input type="text"/> <CR> (vol = 1-255) #HUE? <input type="text"/> <CR> #COLOR <input type="text"/> <input type="text"/> <input type="text"/> <CR> (vol = 1-255) #COLOR? <input type="text"/> <CR>
Quad / Full	#QUAD <CR> #FULL <input type="text"/> <CR>
Set / Get Active window	#WIN <input type="text"/> <CR> #WIN? <CR>
Set / Get window source	#SRC-VID <input type="text"/> <input type="text"/> <CR> #SRC-VID? <input type="text"/> <CR>
Set / Get Vertical Mirror Status / Horizontal Mirror Status / Freeze status / Blank Status	#SRC-VMIR <input type="text"/> <input type="text"/> <input type="text"/> <CR> (status = 1 – ON, 0 – OFF) #SRC-VMIR? <input type="text"/> <CR> #SRC-HMIR <input type="text"/> <input type="text"/> <input type="text"/> <CR> (status = 1 – ON, 0 – OFF) #SRC-HMIR? <input type="text"/> <CR> #SRC-FREEZE <input type="text"/> <input type="text"/> <input type="text"/> <CR> (status = 1 – ON, 0 – OFF) #SRC-FREEZE? <input type="text"/> <CR> #SRC-BLANK <input type="text"/> <input type="text"/> <input type="text"/> <CR> (status = 1 – ON, 0 – OFF) #SRC-BLANK? <input type="text"/> <CR>
Set / Get Normal / Overscan mode	#MODE <input type="text"/> <CR> (mode=0--normal, 1--overscan) #MODE? <CR>
Zoom On / Off	#ZOOM <input type="text"/> <input type="text"/> X, Y<CR> (zoom_mode=1-ON,0-OFF; X=horizontal left, Y=vertical top)

Examples	
Function	Command Syntax
Set coordinates for window 2. Top left (60,0) and bottom right (150,80)	#CRDT 2, 60, 0, 150, 80 <input type="text"/>
Set brightness of input 3 to 140	#BRIGHTNESS 3, 140 <input type="text"/>
Get contrast for input 4 Response: Contrast of input 4 is 125	#CONTRAST? 4 <input type="text"/> ~CONTRAST 4, 125 <input type="text"/>
Freeze window 2	#SRC-FREEZE 2, 1 <input type="text"/>

Preset commands		
Command	Syntax	Response
Store current connections to preset	#PRST-STO <input type="text"/> <input type="text"/> Short form: #PSTO <input type="text"/> <input type="text"/>	~PRST-STO <input type="text"/> <input type="text"/> <input type="text"/>
Recall saved preset	#PRST-RCL <input type="text"/> <input type="text"/> Short form: #PRCL <input type="text"/> <input type="text"/>	~PRST-RCL <input type="text"/> <input type="text"/> <input type="text"/>
Delete saved preset	#PRST-DEL <input type="text"/> <input type="text"/> Short form: #PDEL <input type="text"/> <input type="text"/>	~PRST-DEL <input type="text"/> <input type="text"/> <input type="text"/>

Preset commands		
Command	Syntax	Response
Read saved presets list	#PRST-LST? <input type="text" value="CR"/> Short form: #PLST? <input type="text" value="CR"/>	~PRST-LST <input type="text" value="PRESET"/> <input type="text" value="PRESET"/> , ... <input type="text" value="CRLF"/>
Parameters Description: <input type="text" value="PRESET"/> = Preset number = 1 - 10 <input type="text" value="OUT"/> = Output in preset to show for, "*" for all.		

Examples:		
Store current Audio & Video connections to preset 5	#PRST-STR 5 <input type="text" value="CR"/>	~PRST-STR 5 OK <input type="text" value="CRLF"/>
Recall Audio & Video connections from preset 3	#PRCL 3 <input type="text" value="CR"/>	~PRST-RCL 3 OK <input type="text" value="CRLF"/>

Machine info commands		
Command	Syntax	Response
* Time settings commands require admin authorization		
Read inouts count	#INFO-IO? <input type="text" value="CR"/>	~INFO-IO: IN <input type="text" value="INPUTS_COUNT"/> , OUT <input type="text" value="OUTPUTS_COUNT"/> <input type="text" value="CRLF"/>
Read max presets count	#INFO-PRST? <input type="text" value="CR"/>	~INFO-PRST: VID <input type="text" value="PRESET_VIDEO_COUNT"/> , AUD <input type="text" value="PRESET_AUDIO_COUNT"/> <input type="text" value="CRLF"/>
Reset configuration to factory default	#FACTORY <input type="text" value="CR"/>	~FACTORY <input type="text" value="RESULT"/> <input type="text" value="CRLF"/>

Identification commands		
Command	Syntax	Response
Protocol Handshaking	# <input type="text" value="CR"/>	~OK <input type="text" value="CRLF"/>
Read device model	#MODEL? <input type="text" value="CR"/>	~MODEL <input type="text" value="MACHINE_MODEL"/> <input type="text" value="CRLF"/>
Read device serial number	#SN? <input type="text" value="CR"/>	~SN <input type="text" value="SERIAL_NUMBER"/> <input type="text" value="CRLF"/>
Read device firmware version	#VERSION? <input type="text" value="CR"/>	~VERSION <input type="text" value="MAJOR"/> <input type="text" value="MINOR"/> <input type="text" value="BUILD"/> <input type="text" value="REVISION"/> <input type="text" value="CRLF"/>
Set machine name	#NAME <input type="text" value="MACHINE_NAME"/> <input type="text" value="CR"/>	~NAME <input type="text" value="MACHINE_NAME"/> <input type="text" value="RESULT"/> <input type="text" value="CRLF"/>
Read machine name	#NAME? <input type="text" value="CR"/>	~NAME <input type="text" value="MACHINE_NAME"/> <input type="text" value="CRLF"/>
Reset machine name to factory default*	#NAME-RST <input type="text" value="CR"/>	~NAME-RST <input type="text" value="MACHINE_FACTORY_NAME"/> <input type="text" value="RESULT"/> <input type="text" value="CRLF"/>
*Note: machine name not equal to model name. This name relevance for site viewer identification of specific machine or for network using (with DNS feature on). <input type="text" value="MACHINE_NAME"/> = Up to 14 Alfa-Numeric chars.		

Identification commands		
Command	Syntax	Response
* Machine factory name = Model name + last 4 digits from serial number.		

Network settings commands		
Set IP Address	#NET-IP <u>IP_ADDRESS</u> <u>CR</u> #NTIP <u>CR</u>	~NET-IP <u>IP_ADDRESS</u> <u>RESULT</u> <u>CRLF</u>
Read IP Address	#NET-IP? <u>CR</u> #NTIP? <u>CR</u>	~NET-IP <u>IP_ADDRESS</u> <u>CRLF</u>
Read MAC Address	#NET-MAC? <u>CR</u> #NTMC <u>CR</u>	~NET-MAC <u>MAC_ADDRESS</u> <u>CRLF</u> <u>CRLF</u>
Set subnet mask	#NET-MASK <u>SUBNET_MASK</u> <u>CR</u> #NTMSK <u>CR</u>	~NET-MASK <u>SUBNET_MASK</u> <u>RESULT</u> <u>CRLF</u>
Read subnet mask	#NET-MASK? <u>CR</u> #NTMSK? <u>CR</u>	~NET-MASK <u>SUBNET_MASK</u> <u>CRLF</u>
Set gateway address	#NET-GATE <u>GATEWAY_ADDRESS</u> #NTGT	~NET-GATE <u>GATEWAY_ADDRESS</u> <u>RESULT</u>
Read subnet mask	#NET-GATE? #NTGT?	~NET-GATE <u>GATEWAY_ADDRESS</u> <u>CRLF</u>
Set DHCP mode	#NET-DHCP <u>DHCP_MODE</u> <u>CR</u> #NTDH <u>CR</u>	~NET-DHCP <u>DHCP_MODE</u> <u>RESULT</u> <u>CRLF</u>
Read subnet mask	#NET-DHCP? <u>CR</u> #NTDH? <u>CR</u>	~NET-DHCP <u>DHCP_MODE</u> <u>CRLF</u>

DHCP_MODE =

0 – Don't use DHCP (Use IP set by factory or IP set command).

1 – Try to use DHCP, if unavailable use IP as above.

Change protocol ethernet port	#ETH-PORT <u>PROTOCOL</u> . <u>PORT</u> <u>CR</u> #ETHP <u>CR</u>	~ETH-PORT <u>PROTOCOL</u> . <u>PORT</u> <u>RESULT</u> <u>CRLF</u>
Read protocol ethernet port	#ETH-PORT? <u>PROTOCOL</u> <u>CR</u> #ETHP? <u>CR</u>	~ETH-PORT <u>PROTOCOL</u> . <u>PORT</u> <u>CRLF</u>

PROTOCOL = TCP / UDP (transport layer protocol)

PORT = ethernet port to enter protocol 3000 commands.

1-65535 = User defined port

0 - reset port to factory default (50000 for UDP, 5000 for TCP)

LIMITED WARRANTY

We warrant this product free from defects in material and workmanship under the following terms.

HOW LONG IS THE WARRANTY

Labor and parts are warranted for seven years from the date of the first customer purchase.

WHO IS PROTECTED?

Only the first purchase customer may enforce this warranty.

WHAT IS COVERED AND WHAT IS NOT COVERED

Except as below, this warranty covers all defects in material or workmanship in this product. The following are not covered by the warranty:

1. Any product which is not distributed by us or which is not purchased from an authorized Kramer dealer. If you are uncertain as to whether a dealer is authorized, please contact Kramer at one of the agents listed in the Web site www.kramerelectronics.com.
2. Any product, on which the serial number has been defaced, modified or removed, or on which the WARRANTY VOID IF TAMPERED sticker has been torn, reattached, removed or otherwise interfered with.
3. Damage, deterioration or malfunction resulting from:
 - i) Accident, misuse, abuse, neglect, fire, water, lightning or other acts of nature
 - ii) Product modification, or failure to follow instructions supplied with the product
 - iii) Repair or attempted repair by anyone not authorized by Kramer
 - iv) Any shipment of the product (claims must be presented to the carrier)
 - v) Removal or installation of the product
 - vi) Any other cause, which does not relate to a product defect
 - vii) Cartons, equipment enclosures, cables or accessories used in conjunction with the product

WHAT WE WILL PAY FOR AND WHAT WE WILL NOT PAY FOR

We will pay labor and material expenses for covered items. We will not pay for the following:

1. Removal or installations charges.
2. Costs of initial technical adjustments (set-up), including adjustment of user controls or programming. These costs are the responsibility of the Kramer dealer from whom the product was purchased.
3. Shipping charges.

HOW YOU CAN GET WARRANTY SERVICE

1. To obtain service on you product, you must take or ship it prepaid to any authorized Kramer service center.
2. Whenever warranty service is required, the original dated invoice (or a copy) must be presented as proof of warranty coverage, and should be included in any shipment of the product. Please also include in any mailing a contact name, company, address, and a description of the problem(s).
3. For the name of the nearest Kramer authorized service center, consult your authorized dealer.

LIMITATION OF IMPLIED WARRANTIES

All implied warranties, including warranties of merchantability and fitness for a particular purpose, are limited in duration to the length of this warranty.

EXCLUSION OF DAMAGES

The liability of Kramer for any effective products is limited to the repair or replacement of the product at our option. Kramer shall not be liable for:

1. Damage to other property caused by defects in this product, damages based upon inconvenience, loss of use of the product, loss of time, commercial loss; or:
2. Any other damages, whether incidental, consequential or otherwise. Some countries may not allow limitations on how long an implied warranty lasts and/or do not allow the exclusion or limitation of incidental or consequential damages, so the above limitations and exclusions may not apply to you.

This warranty gives you specific legal rights, and you may also have other rights, which vary from place to place.

NOTE: All products returned to Kramer for service must have prior approval. This may be obtained from your dealer.

This equipment has been tested to determine compliance with the requirements of:

- EN-50081: "Electromagnetic compatibility (EMC);
generic emission standard.
Part 1: Residential, commercial and light industry"
- EN-50082: "Electromagnetic compatibility (EMC) generic immunity standard.
Part 1: Residential, commercial and light industry environment".
- CFR-47: FCC* Rules and Regulations:
Part 15: "Radio frequency devices
Subpart B Unintentional radiators"

CAUTION!

- Servicing the machines can only be done by an authorized Kramer technician. Any user who makes changes or modifications to the unit without the expressed approval of the manufacturer will void user authority to operate the equipment.
- Use the supplied DC power supply to feed power to the machine.
- Please use recommended interconnection cables to connect the machine to other components.
* FCC and CE approved using STP cable (for twisted pair products)



For the latest information on our products and a list of Kramer distributors, visit www.kramerelectronics.com where updates to this user manual may be found. We welcome your questions, comments and feedback.



Caution

Safety Warning:

Disconnect the unit from the power supply before opening/servicing.



Kramer Electronics, Ltd.

Web site: www.kramerelectronics.com

E-mail: info@kramerel.com

P/N: 2900-000653 REV 2