

ROBE

ROBIN[®] ParFect 150

ROBIN[®] ParFect 150 FW

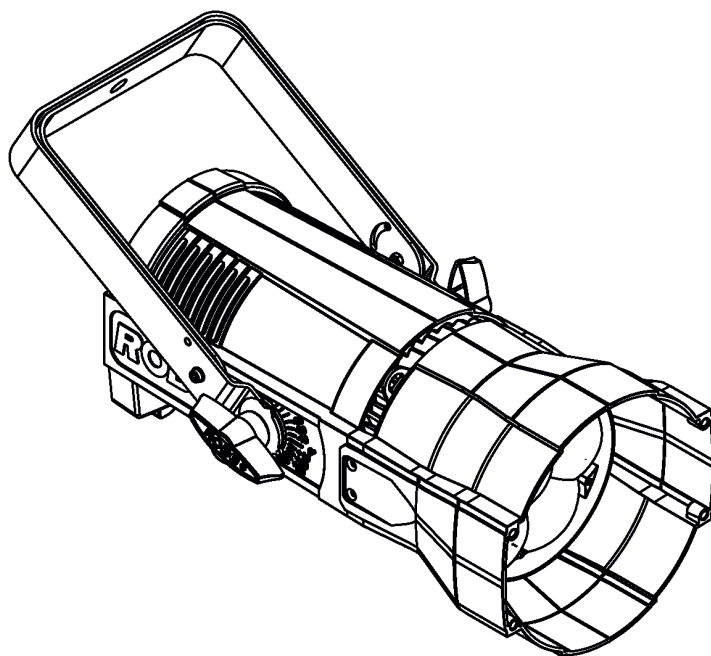

USER MANUAL

ROBE[®] lighting s.r.o. • Czech Republic • www.robe.cz

Version 1.5

ROBIN ParFect 150

ROBIN ParFect 150 FW

Table of contents

| | |
|---|-----------|
| 1. Safety instructions | 3 |
| 2. Fixture exterior view | 5 |
| 3. Installation | 6 |
| 3.1 Connection to the mains | 6 |
| 3.2 Installing barndoors and the gel frame | 7 |
| 3.3 Installing the eggcrate | 8 |
| 3.4 Installing the diffuser 2° | 9 |
| 3.5 Rigging the fixture | 10 |
| 3.6 DMX-512 connection..... | 12 |
| 3.7 Wireless DMX operation | 13 |
| 4. Control menu map | 14 |
| 5. Control menu (Standard and Easy control mode) | 16 |
| 5.1 Addressing (DMXA)..... | 16 |
| 5.2 Fixture information (Info) | 17 |
| 5.3 Personality (Pers)..... | 17 |
| 5.4 Manual Control (Manual)..... | 18 |
| 5.5 Test program (Test Prg)..... | 18 |
| 5.6 Stand-alone (St Alone) | 18 |
| 5.7 Special functions (Special)..... | 19 |
| 6. RDM | 21 |
| 7. Error and information messages | 22 |
| 8. Technical Specifications | 22 |
| 9. Maintenance and cleaning | 24 |
| 9.1 Replacing the fuse | 24 |
| 9.2 Disposing of the product | 25 |
| 10. Photometric diagrams | 26 |
| 10.1 ROBIN Parfect 150 | 26 |
| 10.2 ROBIN Parfect 150 FW..... | 30 |
| 11. ChangeLog | 32 |

**FOR YOUR OWN SAFETY, PLEASE READ THIS USER MANUAL CAREFULLY
BEFORE POWERING OR INSTALLING YOUR ROBIN ParFect 150 !**

Save it for future reference.

This device has left our premises in absolutely perfect condition. In order to maintain this condition and to ensure a safe operation, it is absolutely necessary for the user to follow the safety instructions and warning notes written in this manual.

The manufacturer will not accept liability for any resulting damages caused by the non-observance of this manual or any unauthorized modification to the device.

Please consider that damages caused by manual modifications to the device are not subject to warranty.

The ParFect 150 was designed for indoor use and it is intended for professional application only. It is not for household use.

1. Safety instructions

DANGEROUS VOLTAGE CONSTITUTING A RISK OF ELECTRIC SHOCK IS PRESENT WITHIN THIS UNIT!

Make sure that the available voltage is not higher than stated on the rear panel of the fixture. This fixture should be operated only from the type of power source indicated on the marking label. If you are not sure of the type of power supplied, consult your authorized distributor or local power company.

Always disconnect the fixture from AC power before cleaning, removing or installing any part of the fixture.

The power plug has to be accessible after installing the fixture. Do not overload wall outlets and extension cords as this can result in fire or electric shock.

Do not allow anything to rest on the power cord. Do not locate this fixture where the cord may be damaged by persons walking on it.

Make sure that the power cord is never crimped or damaged by sharp edges. Check the fixture and the power cord from time to time.

Refer servicing to qualified service personnel.

This fixture falls under protection class I. Therefore this fixture has to be connected to a mains socket outlet with a protective earthing connection.

Do not connect this fixture to a dimmer pack.

**Warning! Risk Group 2 LED product according to EN 62471.
LED light emission. Risk of eye injury. Do not look into the beam at short distance of the of the product. Do not view the light output with optical instruments or any device that may concentrate the beam.
The light source contains blue LEDs.**

If the fixture has been exposed to drastic temperature fluctuation (e.g. after transportation), do not switch it on immediately. The arising condensation water might damage your device. Leave the device switched off until it has reached room temperature.

Avoid brute force when installing or operating the fixture.

This fixture was designed for indoor use only, do not expose this unit to rain or use near water.

When choosing the installation spot, please make sure that the fixture is not exposed to extreme heat, moisture or dust.

Do not block the lens array with any object when the fixture is under operation.

Openings in housing of the fixture should never be covered with cloth or other materials, and never must be blocked.

This fixture should not be placed in a built-in installation unless proper ventilation is provided.

Only operate the fixture after having checked that the housing is firmly closed and all screws are tightly fastened.

Make sure that the area below the installation place is blocked when rigging, derigging or servicing the fixture.

To avoid damage of an internal optical system of the fixture, never let the sunlight (or other light source) lights directly to the lens array, even when the fixture is not working

The fixture becomes hot during operation. Allow the fixture to cool approximately 15 minutes prior to manipulate with it.

Operate the fixture only after having familiarized with its functions. Do not permit operation by persons not qualified for operating the fixture. Most damages are the result of unprofessional operation!

Please use the original packaging if the fixture is to be transported.

Please consider that unauthorized modifications on the fixture are forbidden due to safety reasons!

If this device will be operated in any way different to the one described in this manual, the product may suffer damages and the guarantee becomes void. Furthermore, any other operation may lead to dangers like short-circuit, burns, electric shock, crash etc.

2. Fixture exterior view

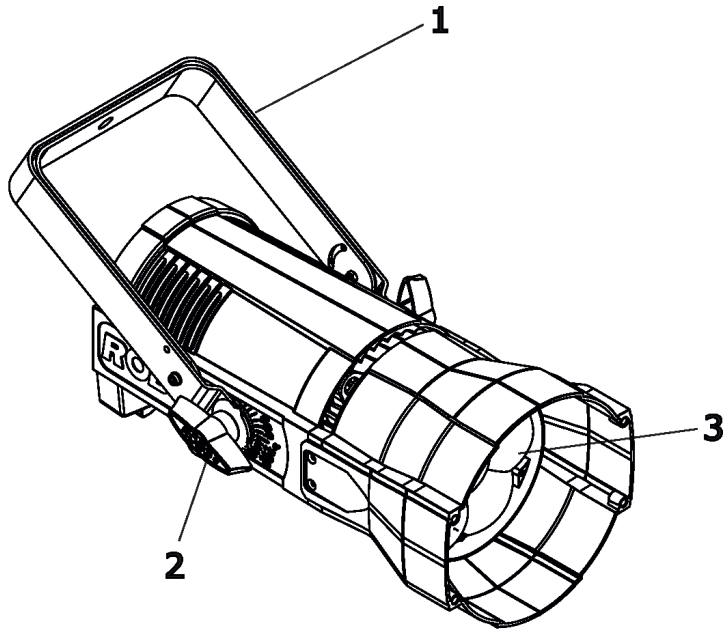

- 1 - Mounting yoke
- 2 - Tilt locks
- 3 - Lenses array

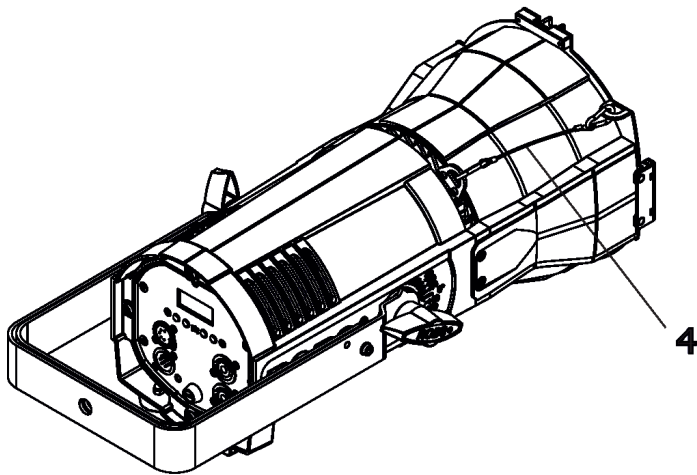

- 4 - Safety wire securing accessory frame adaptor to the housing
- 5 - DMX OUT
- 6 - DMX IN
- 7 - Fuse holder
- 8 - Mains IN
- 9 - Mains OUT
- 10 - Display and control buttons
- 11 - Safety wire attachment point

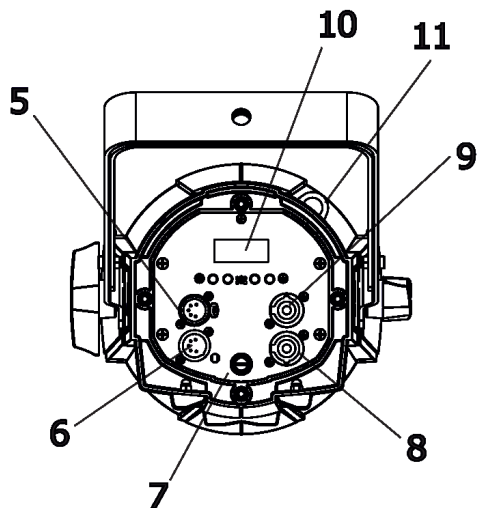

3. Installation



Fixtures must be installed by a Qualified electrician in accordance with all national and local electrical and construction codes and regulation.

3.1 Connection to the mains

For protection from electric shock, the fixture must be earthed!

The ParFect 150 is equipped with auto-switching power supply that automatically adjusts to any 50-60Hz AC power source from 100-240 Volts.

If you need to install a cord cap on the power cable to allow connection to power outlet, install a grounding-type (earthed) plug, following the plug manufacturer's instructions.

If you have any doubts about proper installation, consult a qualified electrician.

| Core (EU) | Core (US) | Connection | Plug Terminal Marking |
|--------------|-----------|------------|-----------------------|
| Brown | Black | Live | L |
| Light blue | White | Neutral | N |
| Yellow/Green | Green | Earth | |

This device falls under class one and must be earthed (grounded)!

The max. number of connected fixtures depends on AC mains power voltage:

CE:

15 fixtures at power supply= 230V

13 fixtures at power supply= 208V

7 fixtures at power supply= 120V

ETL:

9 fixtures at power supply= 230V

8 fixtures at power supply= 208V

4 fixtures at power supply= 120V

Actual number of fixtures may differ from values stated above as you have to take into account the length of supply cables, circuit breaker etc. at projecting of the fixtures installation Do not overload the supply line and connecting leads.

Wiring and connection work must be carried out by qualified staff!

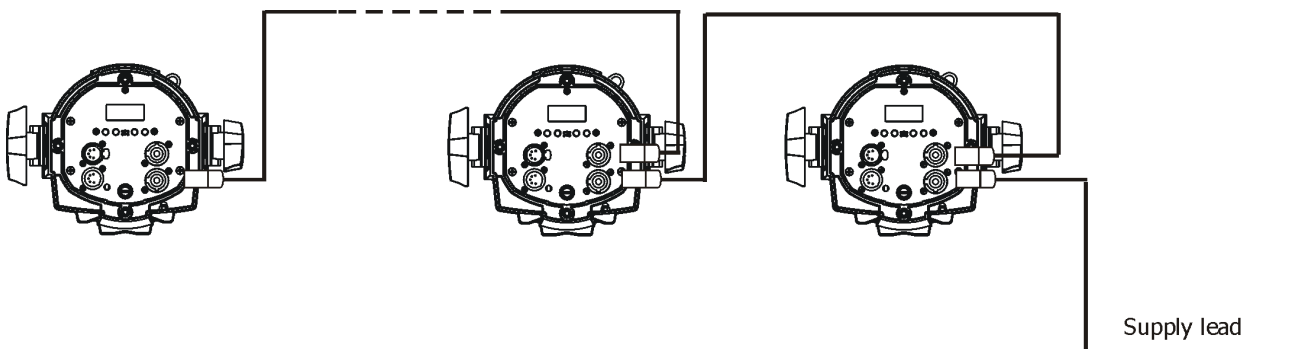

3.2 Installing barndoors and the gel frame

**Disconnect the fixture from mains before barndoors and the gel frame installation!
DO NOT install the gel frame if the eggcrate has been installed on the fixture!**

1. Unlock the spring lock (1) of the accessory frame adaptor (2) via pushing this spring lock as show red arrows on the picture.
2. Insert the gel frame (3) into the bottom slots of the accessory frame adaptor (2).
3. Insert the barndoors (4) into the top slots of the (2).

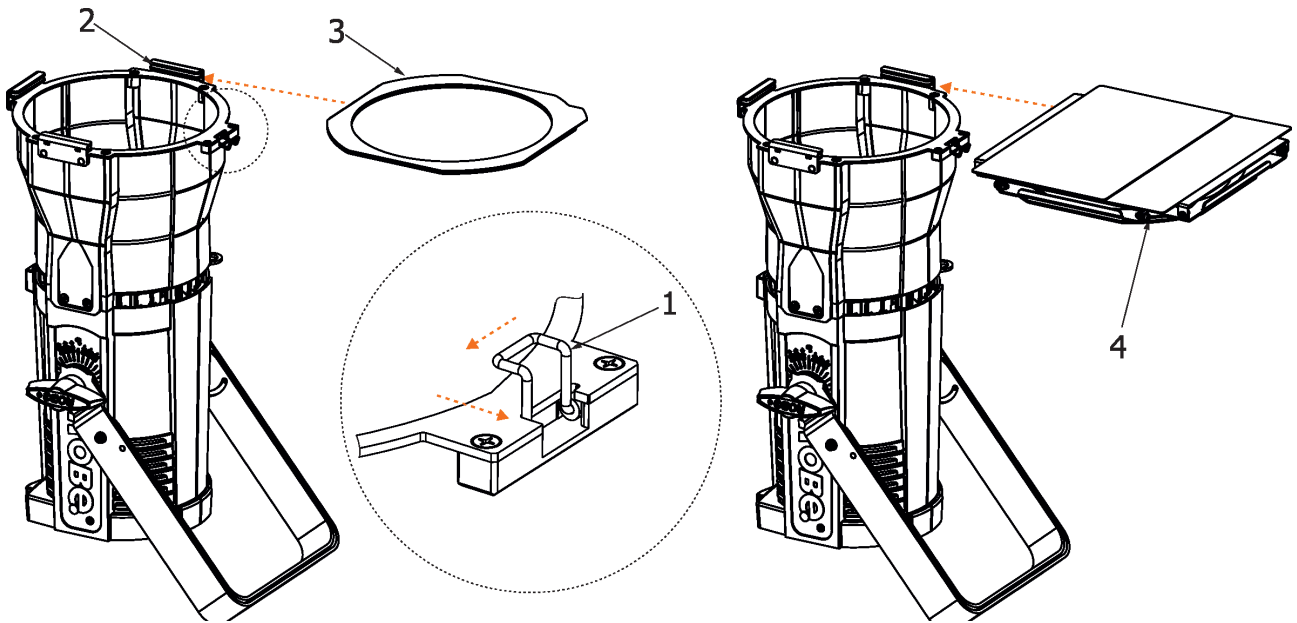

4. Secure both accessories by moving the spring lock (1) to locked position as shows the red arrow on the picture.

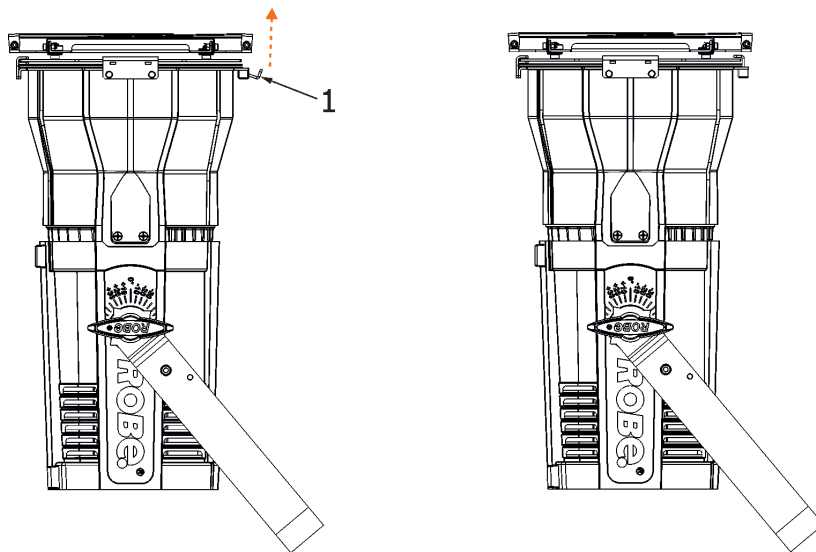

Note: the barndoors can be rotated to desired position and secured in this position via the securing screw (5).

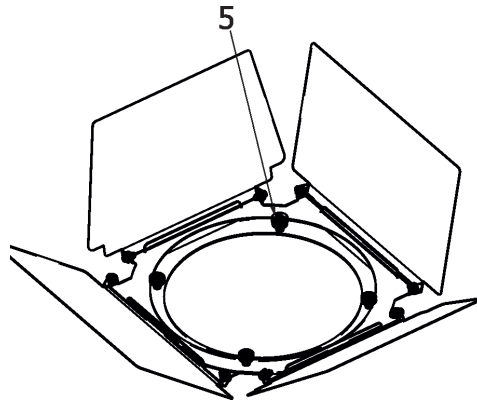

3.3 Installing the eggcrate

**Disconnect the fixture from mains before eggcrate installation!
DO NOT insert the gel frame after installing the eggcrate on the fixture!**

Screw the eggcrate (1) on the lens array module via the three screws (2).

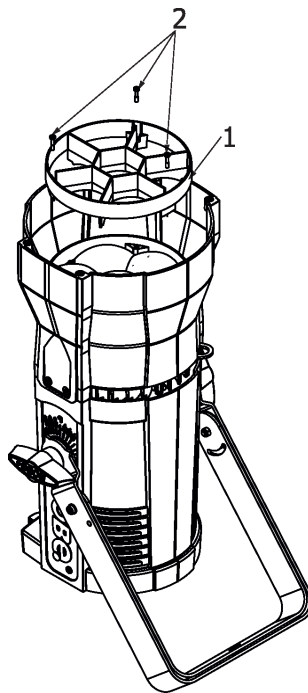

3.4 Installing the diffuser 2° (Robin Perfect 150 only)

Disconnect the fixture from mains before installing the eggcrate.

1. Unscrew three screws (1) from fixture head and remove the plastic lens (2).
2. Place the diffuser 2° (3) to the fixture head, glossy side towards LEDs (correctly aim apertures (4) for screws).
3. Screw the diffuser 2° (3) back to the head by means of the three screws (1)

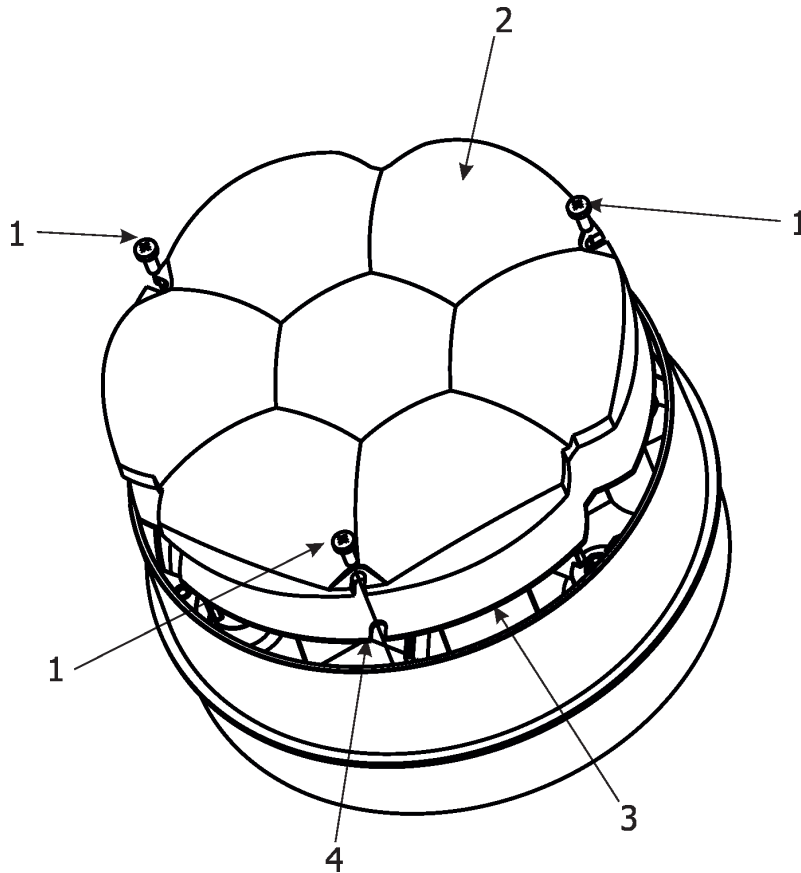

Warning

Installation of the Diffuser 2° is one-time matter as the screws (1) are screwed into the plastic.

You cannot install and uninstall the Diffuser 2° several times.

3.5 Rigging the fixture

A structure intended for installation of the fixture (s) must safely hold weight of the fixture(s) placed on it. The structure has to be certificated to the purpose.

The fixture (fixtures) must be installed in accordance with national and local electrical and construction codes and regulation.

For overhead installation, the fixture must be always secured with a safety wire.

When rigging, derigging or servicing the fixture staying in the area below the installation place, on bridges, under high working places and other endangered areas is forbidden.

The operator has to make sure that safety-relating and machine-technical installations are approved by an expert before taking into operation for the first time and after changes before taking into operation another time.

The operator has to make sure that safety-relating and machine-technical installations are approved by a skilled person once a year.

Allow the fixture to cool for ten minutes before handling.

The projector should be installed outside areas where persons may walk by or be seated.

IMPORTANT! OVERHEAD RIGGING REQUIRES EXTENSIVE EXPERIENCE, including calculating working load limits, installation material being used, and periodic safety inspection of all installation material and the projector. If you lack these qualifications, do not attempt the installation yourself, but use a help of professional companies.

CAUTION: Fixtures may cause severe injuries when crashing down! If you have doubts concerning the safety of a possible installation, do not install the fixture!

The fixture has to be installed out of the reach of public.

The fixture must never be fixed swinging freely in the room.

When installing the device, make sure there is no highly inflammable material (decoration articles, etc.) in a distance of min. 0.4 m.

CAUTION!
Use an appropriate clamp to rig the fixture on the truss.
Make sure that the device is fixed properly! Ensure that the structure (truss) to which you are attaching the fixtures is secure.

The fixture can be placed by means of the unfolded mounting yoke on the stage floor or rigged on a truss (with folded mounting yoke) without altering its operation characteristics.

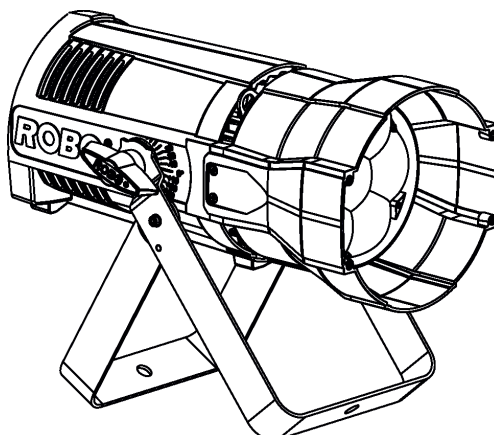

For securing the fixture to the truss, install a safety wire which can hold at least 10 times the weight of the fixture. Use only the safety wire with a snap hook with screw lock gate. **Fasten the safety cable in the attachment point and around the truss as shown on the picture below.**

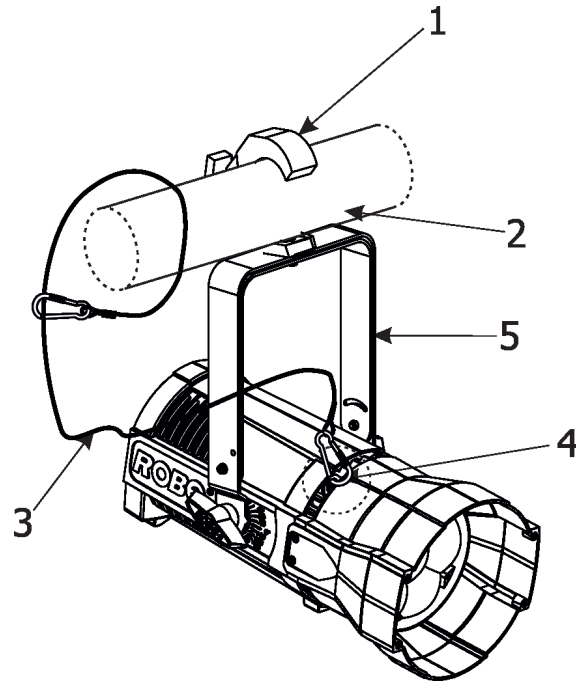

- 1-Clamp
- 2-Truss
- 3-Safety wire
- 4-Attachment point
- 5-Folded mounting yoke

When installing fixtures side-by-side, avoid illuminating one fixture with another!

3.6 DMX-512 connection

The fixture is equipped with 5-pin XLR sockets for DMX input and output. Only use a shielded twisted-pair cable designed for RS-485 and 5-pin XLR-plugs and connectors in order to connect the controller with the fixture or one fixture with another.

DMX output

XLR socket:

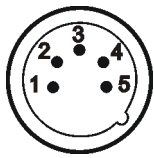

- 1 - Shield
- 2 - Signal (-)
- 3 - Signal (+)
- 4 - Used for wireless DMX
- 5 - Used for wireless DMX

DMX input

XLR plug:

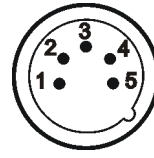

- 1 - Shield
- 2 - Signal (-)
- 3 - Signal (+)
- 4 - Used for wireless DMX
- 5 - Used for wireless DMX

If you are using the standard DMX controllers, you can connect the DMX output of the controller directly with the DMX input of the first fixture in the DMX-chain. If you wish to connect DMX-controllers with other XLR-outputs, you need to use adapter-cables.

Building a serial DMX-chain:

Connect the DMX-output of the first fixture in the DMX-chain with the DMX-input of the next fixture. Always connect one output with the input of the next fixture until all fixtures are connected. Up to 32 fixtures can be interconnected.

Caution: At the last fixture, the DMX-cable has to be terminated with a terminator. Solder a 120 Ω resistor between Signal (-) and Signal (+) into a 5-pin XLR-plug and plug it in the DMX-output of the last fixture.

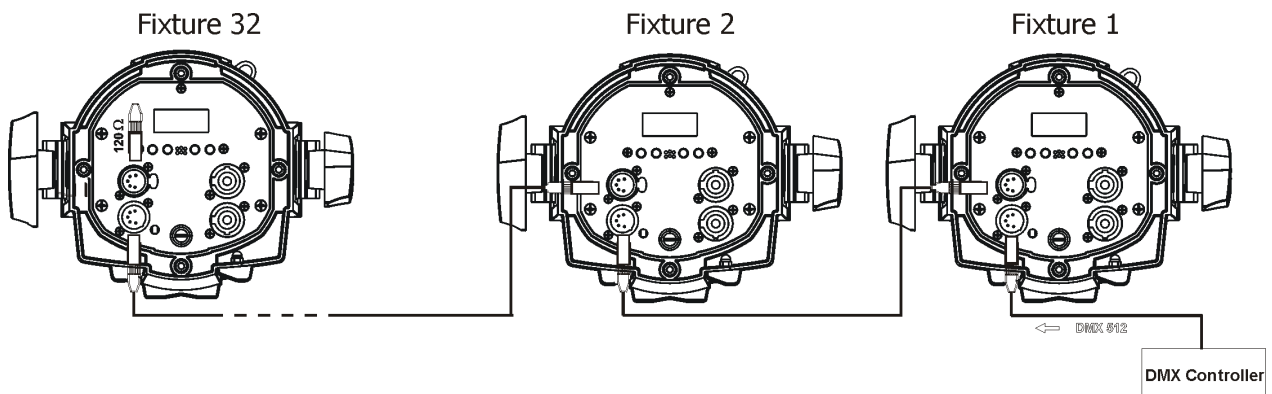

3.7 Wireless DMX operation

The external ROBE Wireless CRMX Dongle allows receiving wireless DMX. This device is equipped with the Lumen Radio CRMX module and antenna for receiving DMX signal. CRMX module operates on the 2.4 GHz band.

ROBE Wireless CRMX Dongle

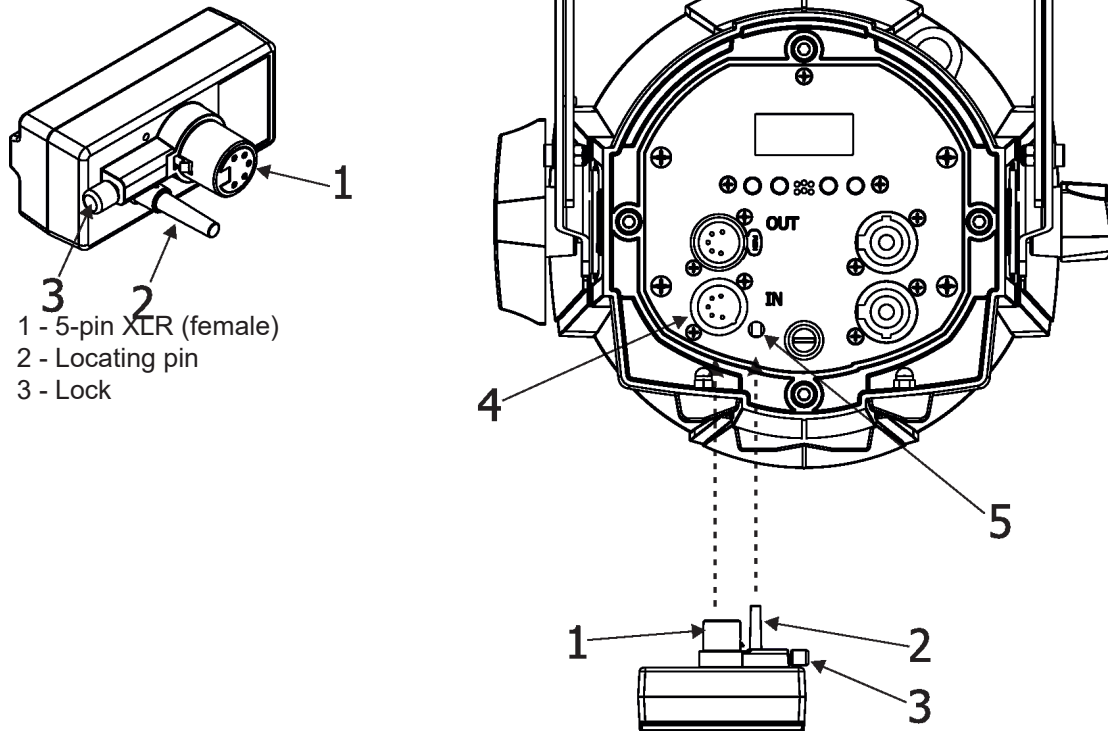

Push the 5-pin XLR plug (1) into 5-pin XLR socket (4) and at the same time locating pin (2) into the opening (5) in the fixture. In this way the wireless DMX module is connected with the fixture.

NOTE: when you disconnecting the DMX wireless module from the fixture, press and hold lock (5) during taking the wireless module out.

To link the fixture with DMX transmitter.

The fixture can be only linked with the transmitter by running the link procedure at DMX transmitter .

After linking , the level of DMX signal (0-100 %) is displayed in the menu item “Stat” (Special -->Wireless -->Stat).

To unlink the fixture from DMX transmitter.

The fixture can be unlinked from receiver via the menu item “ Unlink” (Special-->Wireless -->Unlink.).

4. Control menu map

Default settings=**Bold print**

| Level 1 | Level 2 | Level 3 | Level 4 | Level 5 | Level 6 | Level 7 |
|------------------|----------|---------------------------|----------------|---------|---------|---------|
| DMXA | Set DMXA | 001-512 | | | | |
| | DMX Pres | Mode 1 | | | | |
| | | Mode 2 | | | | |
| Info | POn Time | Total | | | | |
| | | Reset | | | | |
| | DMX In | Powr | 0-255 | | | |
| | | : | | | | |
| | | Dim F | 0-255 | | | |
| | Hea Temp | Current | | | | |
| | | Highest | | | | |
| | | High Res | | | | |
| | Sw Ver | IC-1 | | | | |
| | | IC-2 | | | | |
| Pers | DMX Pres | Mode 1 | | | | |
| | | Mode 2 | | | | |
| | Display | Turn | | | | |
| | | On/Off T | On, Off | | | |
| | | Contrast | 0-100% | | | |
| | | Backlight | 0-100% | | | |
| | Mic Sens | 0... 10 ...19 | | | | |
| | Fans | Auto , High, Quiet | | | | |
| | Col Mix | RGBW , CMY | | | | |
| | White P | On , Off | | | | |
| | Dimmer C | Square , Linear | | | | |
| | Temp Uni | °C , °F | | | | |
| | I Ef Pos | Powr | | | | |
| | | : | | | | |
| | | Dimm F | | | | |
| | Store | | | | | |
| | Defaults | | | | | |
| Manual | Manual C | Powr | 0-255 | | | |
| | | : | | | | |
| | | Dim F | 0-255 | | | |
| Test Prg | | | | | | |
| | | | | | | |
| Sta Alone | Music T | On, Off | | | | |
| | Auto Run | Off | | | | |
| | | Test | | | | |
| | | Prog 1 | | | | |
| | | : | | | | |
| | | Prog 3 | | | | |
| | Pr Play | Test Prg | | | | |
| | | Prog 1 | | | | |
| | | : | | | | |
| | | Prog 3 | | | | |
| Pr Edit | Prog 1 | Step 1 | Powr | | | |
| | Prog 2 | : | : | | | |

| Level 1 | Level 2 | Level 3 | Level 4 | Level 5 | Level 6 | Level 7 |
|----------------|-----------|----------------|----------|---------|---------|---------|
| | | Prog 3 | Step 40 | F.Tim | 0-25.5 | |
| | | | | S.Tim | 0-25.5 | |
| | | | | COPY | | |
| | | | | Prg En | 1-40 | |
| | | | | | | |
| Special | RDM Low | | | | | |
| | RDM Hight | | | | | |
| | Wireless | Stat | | | | |
| | | Unlink | | | | |
| | Adjust | DMX Val | Powr | 0-255 | | |
| | | | : | | | |
| | | | Dim F | 0-255 | | |
| | | Clalib | Cal Mech | Zoom C | 0-255 | |
| | | | | Store | | |
| | | | Cal Col | Red C | 0-255 | |
| | | | | Gre C | 0-255 | |
| | | | | Blu C | 0-255 | |
| | | | | Whi C | 0-255 | |
| | | | | Store | | |
| | | | Cla Load | | | |
| | Sw Upd | On, Off | | | | |

5. Control menu (Standard and Easy control mode)

The ParFect 150 is equipped with 2-row LCD display which allows to set the fixture's behaviour according to your needs, obtain information on its operation, test its various parts and lastly program it, if it has to be used in a stand-alone mode.

Control panel

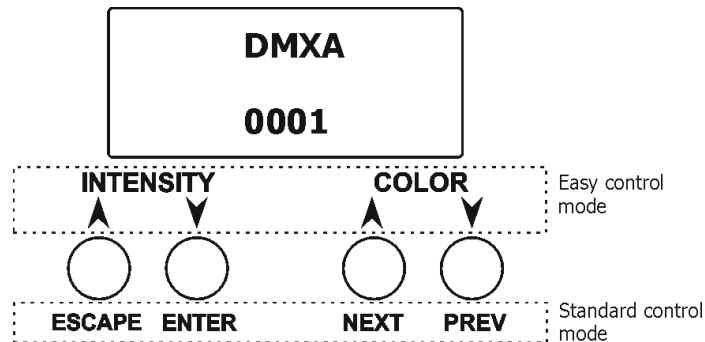

The four control buttons have the following functions:

Standard control mode (default setting)

[ESCAPE] button used to leave the menu without saving changes.

[NEXT] , [PREV] buttons for moving between menu items and for value adjusting.

[ENTER] button used to enter the selected menu (menu item) and to confirm adjusted value.

After switching the fixture on, the display shows current DMX address.

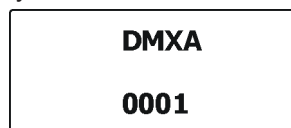

Easy control mode

[INTENSITY] buttons used to set light intensity (dimmer).

[COLOR] buttons used to set colour

After switching the fixture on, the display shows adjusted dimmer intensity and colour before switching the Parfect 150 off.

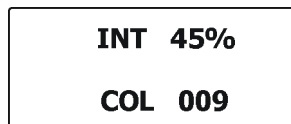

When the fixture is switched off, both adjusted color and light intensity are saved into memory to use them after switching the fixture on.

Note: DMX control in this mode is disabled.

Switching the fixture to Easy control mode

When the current DMX address is displayed:

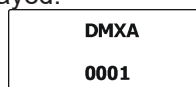

press the [NEXT] and [PREV] buttons at the same time until the screen for the Easy control mode appears.

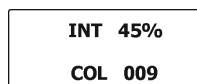

For switching to the Standard control mode, press the [NEXT] and [PREV] buttons at the same time until the screen for the Standard control mode appears.

The following menu items are accessible in the Standard control mode only.

5.1 Addressing (DMXA)

Set DMXA- Use this menu item to set the DMX start address of the fixture, which is defined as the first channel from which the ParFect 150 will respond to the controller.

If you set, for example, the address 31, the ParFect 150 will use channels 31 - 48 for control (if Mode 1 is selected).

Please, be sure that you do not have any overlapping channels in order to control each ParFect 150 correctly and independently from any other fixture on the DMX data link.

If there is no data received at the DMX input, the display will start to flash "0001" with actually stored DMX address.

DMX Pres - DMX preset. Use the menu to select desired channel mode.

Mode 1 - 17 control channels (default)

Mode 2 - 11 control channels

5.2 Fixture information (Info)

POn Time - Power on time. Select this menu to read the number of fixture operation hours.

Total - The item shows the total number of the operation hours since the ParFect 150 has been fabricated.

Reset - The item shows the number of the operation hours that the ParFect 150 has been powered on since the counter was last reset.

In order to reset this counter to 0, press and hold both [NEXT] and [PREV] buttons and the [Enter] button at the same time.

DMX In - DMX readout. The menu is used to read DMX values of each channel received by the fixture.

Hea. Temp - Temperature. The menu shows temperature of the LED module.

Current - A current temperature of the LED module.

Highest - A maximum temperature of the the LED module since the fixture has been fabricated.

High Res - A maximum temperature of the the LED module since the counter was last reset.

In order to reset this counter, press and hold both [NEXT] and [PREV] buttons and the [Enter] button at the same time.

Sw Ver - Software versions. Select this item to read the software version of the fixture modules.

IC-1 - A display processor.

IC-2 - A LED control processor.

5.3 Personality (Pers)

DMX Pres - DMX preset. Use the menu to select desired channel mode.

Mode 1 - 17 control channels (default)

Mode 2 - 11 control channels

Display - Display adjusting. This menu allows you to adjust the display behaviour.

Turn - This function rotates menu 180 degrees from current orientation.

Note: Pressing and holding the Escape button also rotates menu.

On/Off T - This function allows you to keep the display permanent on or turn it off two minutes after last pressing any button on the control panel.

Contrast- Use this function to adjust contrast of the display (0-100%).

Backlight- Use this function to adjust backlight of the display (0-100%).

Col. Mix. - Colour mixing mode. This item allows switching into RGBW or CMY mode. In the CMY mode, the white(8bit) and white (16) bit channels are not active.

White P - White Point 8000K. If the function is on, the CTC channel allows to set desired white in range of 8000K-2700K

(0 DMX=8000K, 64 DMX=5600K, 128 DMX=4200K, 192 DMX=3200K, 255 DMX=2700K). Necessary condition is , that RGBW channels have to be full or set at the same DMX values, e.g. 255.

If this function is off, the range of whites is not uniform and may be different for each fixture.

Mic Sens - Microfon sensitivity. Enter the menu if you want to adjust the microphone sensitivity (0-min., 19-max.).

Fan - Fan mode. Use the menu to set the fixture fan to the max. power ("**High**") ,auto-control mode ("**Auto**") and quiet mode ("**Quiet**"). In the quiet mode is a speed of zoom reduced.

Temp Uni - Temperature unit. Use the menu item to change temperature unit from °C to °F.

Ef Pos - Init effect positions. Use the menu to set all effects to the desired positions at which they will stay after switching the fixture on without DMX signal connected.

Defaults - The menu item allows to set all fixture parameters to the default (factory) values.

5.4 Manual Control (Manual)

Use the menu to control all fixture channels by means of the control panel.

5.5 Test program (Test Prg)

Use this menu to to run a special demo-test sequences without an external controller, which will show you some possibilities of using the ParFect 150.

5.6 Stand-alone (St Alone)

The ParFect 150 offers three user-editable programs (Prog 1-Prog 3), each up to 40 steps. T

Music T - Music trigger. Select this function to enable the sound control of the running program via the built-in microphone.

Auto Run - Presetting playback. This function allows you to select the program which will be played in the stand-alone mode after switching the fixture on. Selected program will be played continuously in a loop.

Off - The option disables „Auto Run” function.

Test, Prog 1, Prog 2, Prog 3 - Selected program will start running after switching the fixture on.

Pr Play - Playing program. Select this menu to run a desired program in a loop (Test Prg, Prog 1-Prog 3). Select the program you wish to run and press the [ENTER]. The selected program will start running. By Pressing the [ENTER] again, the program pauses running.

Pr Edit - Editing program. Select this menu to edit or create three editable programs (Prog 1-Prog 3). Each program step has a step time - during which effects last in the current step and a fade time- during which effects move to new positions.

To edit program.

1. Press [NEXT] or [PREV] to select the menu "Pr Edit" and press [ENTER].
2. Press [NEXT] or [PREV] to select the desired program and press [ENTER] button.
3. Press [NEXT] or [PREV] to select the desired program step and press [ENTER] button.
4. Press [NEXT] or [PREV] to select the desired item and press [ENTER] button. Now you can edit by [NEXT] or [PREV] buttons the DMX value (0-255) for selected item:

| | |
|---------|--|
| Prg En. | a total number of the program steps (value 1-40). This value you should be set before starting of programming (e.g. if you want to create program with the 10 steps, set Prg En=10). |
| Powr | power/special functions |
| Virt C | a virtual colour wheel |
| Red | a red colour coarse |
| Red F | a red colour fine |
| Green | a green colour coarse |
| Green F | a green colour fine |
| Blue | a blue colour coarse |
| Blue F | a blue colour fine |
| White | a white colour |
| White F | a white colour fine |
| CTC | a colour temperature correction |
| C Mix C | a colour mix control |
| Zoom | a zoom function |
| Zoom F | a zoom function fine |
| Stro | a strobe/shutter function |

Dimm a dimmer function coarse
 Dim F a dimmer function fine
 F.Tim a fade time (0-25.5 sec)
 S.Tim a step time (0-25.5 sec)
 COPY copying the current prog. step to
 the next prog. step

5. Press [ENTER] button to confirm adjusted value .
6. Press [ESCAPE] button, select next prog. step, press [ENTER] button and repeat steps 4 - 5).

5.7 Special functions (Special)

RDM Low - This menu item shows the first part of the RDM identification code.

RDM High - This menu item shows the second part of the RDM identification code.

Wireless - **Wireless DMX information.** The menu allows to read some information about Wireless DMX operation

Stat - Wireless status. Use the menu to read wireless DMX status.

Unlink - use this item to unlink fixture from wireless DMX.

Adjust - Adjustment. The menu allows the fine adjustment of effects.

DMX Val- DMX values. Use the menu to set DMX values of fixture's channels.

Calib - calibration of white colour.

Cal Mech - Use this menu to calibrate a zoom position.

Cal Col - Use this menu to set white colour 5600K.

Calibration of the zoom position via the control board

1. Disconnect DMX controller from the fixture and enter the "Cal Mech" menu.
2. Use the [PREV] and [NEXT] to find "Zoom C" and press [ENTER].
3. Set desired value and confirm it by pressing [ENTER].
4. After calibration, find item "Store" and press [ENTER]. to save all adjusted values and reset the fixture.

Calibration of the white 5600K via the control board

1. Disconnect DMX controller from the fixture , set the shutter, dimmer and RGBW channels at 255 DMX, zoom at 128 DMX and the CTC channel at DMX=64 (white 5600K). Aim the light beam on the lux meter (e.g. Minolta CL-500 A Chroma meter) which is placed cca 5m from the fixture.
2. Set the menu items Colour Mix Mode to RGBW and "White Point 8000K to On (Pers-> C Mix M -> RGBW, Pers-> White P -> On).
3. Enter the menu "Cal Col".
4. By means of the "Red C, Gre C, Blu C and Whi C" items adjust the 5600K colour temperature as exactly as possible ($\Delta u'v' = 0$).
5. After adjusting 5600K colour temperature, select item Store and press the [ENTER] button to save all adjusted values .

Note: you can also use DMX controller for both calibrations stated above, calibration protocol is the following:

| Effect | Mode 1 | Mode 2 |
|--------------------------|---------------|---------------|
| Zoom -fine adjustment | channel 18 | channel 12 |
| Red - red saturation | channel 19 | channel 13 |
| Green- green saturation | channel 20 | channel 14 |
| Blue - blue saturation | channel 21 | channel 15 |
| White - white saturation | channel 22 | channel 16 |

Cal Load - Loads default (factory) calibration.

Sw Upd - **Software update.** The menu item allows you to update software in the fixture via either serial or USB port of PC.

The following are required in order to update software:

- PC running Windows XP/7/8/10 or Linux
- Update software
- Flash cable RS232/DMX P/N.13050624 (if you want to use a serial port of PC)
- Robe Universal Interface (if you want to use an USB port of PC)

Note 1: Software update should perform a qualified person. If you lack qualification, do not attempt the update yourself and ask for help your ROBE distributor.

Note 2: DMX address, , programs 1-3 and all items in the menu "Pers" will be set to their default (factory) values after software update.

To update software in the fixture:

I. Installation of the update software.

1. Update Software available from the ROBE web site at WWW.robe.cz.
2. Make a new directory (e.g. Robe_Uploader) on your hard disk and download the software to it.
3. Unpack the program to the directory.

II. Fixture software updating.

1. Determine which of your ports is available on your PC and connect it:
 - with the DMX input of the fixture if you using the flash cable RS232/DMX
 - with the USB input of the Robe Universal Interface if you using the USB cable. Connect DMX output of the Robe Universal Interface with the fixture via a standard DMX cabel.Turn both the computer and the fixture on. Make sure the lamp is switched off (only if the fixture has a lamp).

2. Switch the fixture to the updating mode (Special -> "SW Upd "-> On).

Note: If you do not want to continue in software update, you have to switch off and on the fixture to escape from this menu.

We recommend to cancel all running programs on PC before starting the software update.

3. Run the Software Uploader. Select desired COM and then click on the Connect button.

(Select COM if the serial port is used or Robe Universal Interface if the USB port is used).

If the connection is OK, click on the "Start Uploading button" to start uploading. It will take several minutes to perform software update.

If the option "Incremental Update" is not checked, all processors will be updated (including processors with the same software version).

If you wish to update only later versions of processors, check the "Incremental Update box".

Avoid interrupting the process. Update status is being displayed in the Info Box window.

When the update is finished, the line with the text "The fixture is successfully updated" will appear in this window and the fixture will reset with the new software.

Note: In case upload process is interrupted (e.g. power loss), the fixture stays in "Updating mode" and you will have to repeat the software update again.

6. RDM

This fixture supports RDM operation. RDM (Remote Device Management) is a bi-directional communications protocol for use in DMX512 control systems, it is the new open standard for DMX512 device configuration and status monitoring.

The RDM protocol allows data packets to be inserted into a DMX512 data stream without adversely affecting existing non-RDM equipment. By using a special „Start Code,“ and by complying with the timing specifications for DMX512, the RDM protocol allows a console or dedicated RDM controller to send commands to and receive messages from specific moving lights.

RDM allows explicit commands to be sent to a device and responses to be received from it.

The list of commands for the ParFect 150 is the following.

| Parameter ID | Discovery command | SET command | GET command |
|-----------------------------|-------------------|-------------|-------------|
| DISC_UNIQUE_BRANCH | * | | |
| DISC_MUTE | * | | |
| DISC_UN_MUTE | * | | |
| DEVICE_INFO | | | * |
| SUPPORTED_PARAMETERS | | | * |
| SOFTWARE_VERSION_LABEL | | | * |
| DMX_START_ADDRESS | | * | * |
| IDENTIFY_DEVICE | | * | * |
| DEVICE_MODEL_DESCRIPTION | | | * |
| MANUFACTURER_LABEL | | | * |
| DEVICE_LABEL | | * | * |
| SENSOR_DEFINITION | | | * |
| SENSOR_VALUE | | | * |
| DISPLAY_INVERT | | * | * |
| DISPLAY_LEVEL | | * | * |
| DEVICE_RESET | | * | |
| DMX_PERSONALITY | | * | * |
| DMX_PERSONALITY_DESCRIPTION | | | * |
| STATUS_MESSAGES | | | * |
| STATUS_ID_DESCRIPTION | | | * |
| DEVICE_HOURS | | | * |
| PARAMETER_DESCRIPTION | | | * |
| ROBE_DMX_INPUT | | * | * |
| ROBE_WIRELESS_UNLINK | | * | |

7. Error and information messages

Short Err

The message informs you that short circuit has occurred on the LED PCB.

8. Technical Specifications

Electrical

Power supply:.....electronic auto-ranging
Input voltage range:..... 100-240V, 50-60Hz
Fuse:.....T 3.15A
Max. power consumption220W (I=1A, power factor=0.96 at 230V)
Mains input: CE - max. 16A
 ETL - max. 10A
Mains output: CE - max. 15A
 ETL - max. 9A

Optic

Light source: 7 x 30W RGBW multichip LEDs
Min LED life expectancy: 20.000 hours
RGBW/CMY colour mixing
Variable CTO 2700-8000K

Virtual colour wheel

66 preset colours
Halogen lamp effect at whites 2700K and 3200K
Rainbow effect with in both directions with variable speed

Zoom range

Perfect 150: 3.8°-60°
Perfect 150FW: 3.8°-60°

Strobe

Strobe effect with variable speed (0.3 - 20Hz)
Random strobe pulse-effect with variable speed
Opening/closing pulse effect with variable speed

Dimmer

Smooth dimmer from 0 - 100 %

Control

2-row LCD display & 4 buttons
Readout fixture usage, receiving DMX values, temperatures, etc
Built-in analyzer for easy fault finding, error messages
Built-in demo sequences
Quiet fan cooling
Stand-alone operation
3 user editable programs, each up to 40 steps
Supported protocols: USITT DMX 512, RDM,
Support of RDM (Remote Device Management)
2 DMX modes (17, 11 control channels)
2 control modes (Standard and Easy)

External Wireless DMX/RDM module (option)

Compliance with USITT DMX-512 (1986 & 1990) and 512-A
Full DMX fidelity and frame integrity
Auto sensing of DMX frame rate and frame size

<5ms DMX latency
Operational frequency range of 2402-2480 MHz
Producer: LumenRadio

Connection

DMX data in/out: Locking 5-pin XLR
AC power input: Chassis connector Neutrik PowerCon, A-type, NAC3MPA
AC power output: Chassis connector Neutrik PowerCon, B-type, NAC3MPB
Note: mains cable is optional accessories

Rigging

Mounting horizontally or vertically via mounting yoke (305° tilt range)

Temperatures

Maximum ambient temperature : 40° C
Maximum surface temperature : 80° C (at LEDs heat sink)

Distances

Min. distance from flammable surfaces: 0.4 m
Min. distance of illuminated objects: 0.8 m

Total heat dissipation

750 BTU/h (calculated)

Weight

5 kg

Dimensions (mm)

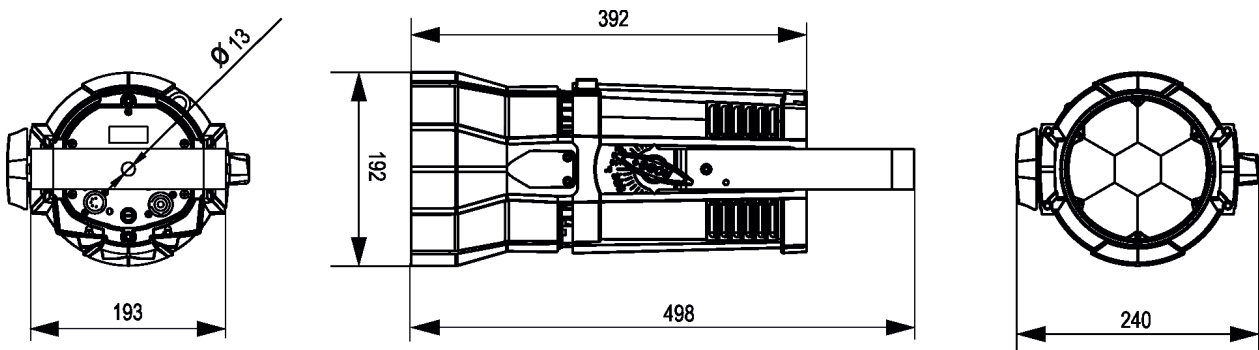

ROBE Wireless CRMX Dongle for compact ROBIN fixtures

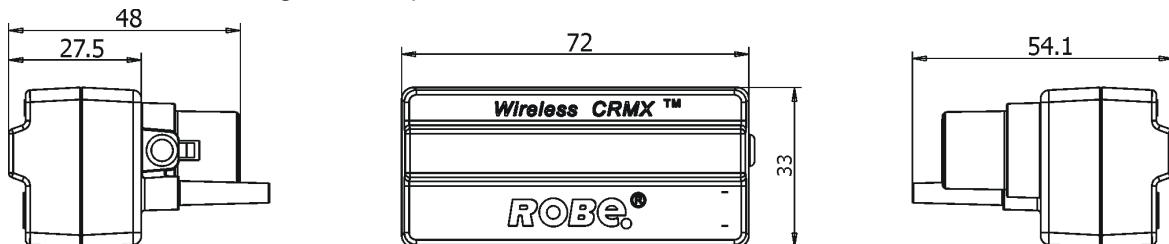

Included items

ROBIN Parfect 150: 1 x ROBIN Parfect 150
1 x Accessory frame adaptor for Parfect 150 (P/N 99015324)
(installed on the fixture)
1 x User manual

ROBIN Parfect 150 FW: 1 x ROBIN Parfect 150 FW
1 x Accessory frame adaptor for Parfect 150 (P/N 99015324)
(installed on the fixture)
1 x User manual

Optional accessories

(P/N 10980127) ROBE Wireless CRMX Dongle for compact ROBIN fixtures
(P/N 10980346) EggCrate for Robin LEDBeam 150/Parfect 150
(P/N 10980348) HALO Frame adaptor for Robin ParFect 150
(P/N 10980349) Barndoor for Robin ParFect 150 black
(P/N 10980415) Barndoor for Robin ParFect 150 white
(P/N 10980372) Gel Frame for Parfect 150
(P/N 10980373) Diffusion filter 2° for Parfect 150 (for installation to gel frame)
(P/N 10980423) Diffusion filter 2° for Parfect 150 (for one-time installation under lenses)
(P/N1305 1731) Mains Cable PowerCon In/open ended, 2m
(P/N 1305 1724) Mains Cable PowerCon In/Schuko, 2m
(P/N 1305 1725) Mains Cable PowerCon In/CEE 16A, 2m
(P/N 1305 1726) Mains Cable PowerCon In/US, 2m
(P/N 1305 1727) Daisy Chain PowerCon In/Out, EU, 2m
(P/N 1305 1728) Daisy Chain PowerCon In/Out, US, 2m
(P/N 17030386) Doughty Trigger Clamp
(P/N 99011963) Safety wire 35 kg

9. Maintenance and cleaning

DANGER !
***Disconnect from the mains before starting any
maintenance work***

A soft lint-free cloth moistened with any good glass cleaning fluid is recommended, under no circumstances should solvents be used!

Never use solvents for cleaning lenses in the fixture!

It is absolutely essential that the fixture is kept clean and that dust, dirt and smoke-fluid residues must not build up on or within the fixture. Otherwise, the fixture's light-output will be significantly reduced. Regular cleaning will not only ensure the maximum light-output, but will also allow the fixture to function reliably throughout its life.

Lenses may require monthly cleaning as smoke-fluid tends to building up residues, reducing the light output very quickly. The cooling fans should be cleaned according to the situation (at least annually). The interior of the base should be cleaned at least annually using a vacuum-cleaner or an air-jet.

More complicated maintenance and service operations are only to be carried out by authorized distributors.

9.1 Replacing the fuse

Replace the fuse by a fuse of the same type and rating only.

Before replacing the fuse, unplug mains lead!

- 1) Remove the fuse holder on the rear panel of the base with a fitting screwdriver from the housing (anti-clockwise).
- 2) Remove the old fuse from the fuse holder.
- 3) Install the new fuse in the fuse holder (only the same type and rating).
- 4) Replace the fuseholder in the housing and fix it.

9.2 Disposing of the product

To preserve the environment please dispose or recycle this product at the end of its life according to the local regulations and codes.

10. Photometric diagrams

10.1 ROBIN Perfect 150

Min. Zoom

Total Output: 1380 lumens

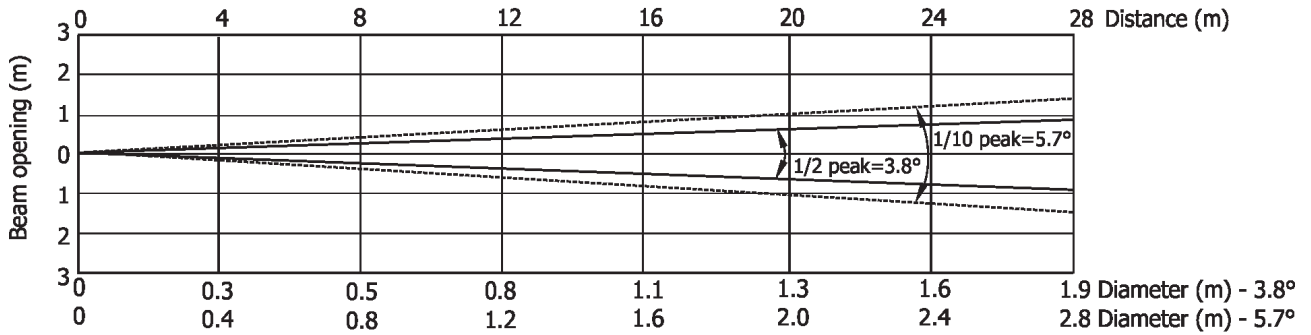

| Distance (m) | 4 | 5 | 8 | 12 | 16 | 20 | 24 | 28 | |
|--------------|------------|------------|----------|----------|----------|--------|--------|--------|---------------------------------------|
| Red | 3938/366 | 2520/234 | 984/92 | 438/41 | 246/23 | 157/15 | 109/10 | 80/8 | Intensity (center) Lux/Footcandles |
| Green | 7484/695 | 4790/445 | 1781/174 | 832/77 | 468/44 | 300/28 | 208/19 | 153/14 | |
| Blue | 1867/157 | 1080/100 | 422/39 | 187/17 | 105/10 | 68/6 | 47/4 | 34/3 | |
| White | 9531/886 | 6100/566 | 2383/221 | 1059/98 | 596/56 | 382/35 | 265/25 | 194/18 | |
| R+G+B+W | 19062/1771 | 12200/1133 | 4765/443 | 2118/197 | 1191/111 | 762/71 | 530/50 | 389/36 | |

Illuminance distribution

Distance=5m

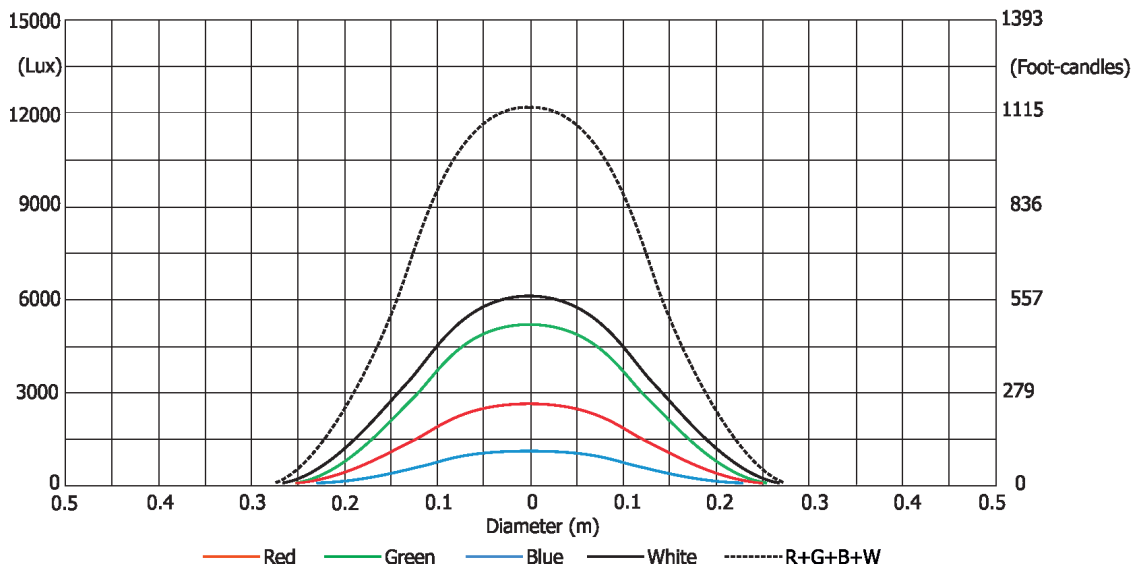

Min. Zoom (with EggCrate)

Total Output: 1143 lumens

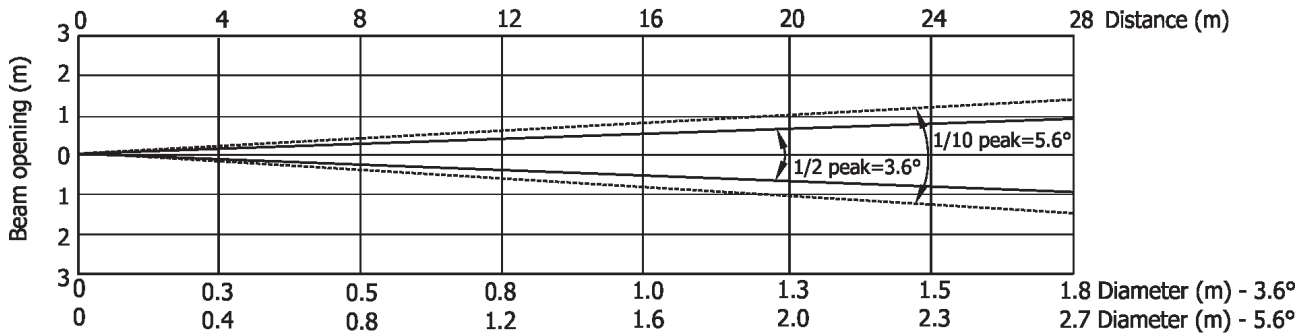

| Distance (m) | 4 | 5 | 8 | 12 | 16 | 20 | 24 | 28 | |
|--------------|------------|------------|----------|----------|----------|----------|--------|--------|---------------------------------------|
| Red | 3906/363 | 2500/232 | 976/91 | 434/40 | 244/23 | 156/14.5 | 109/10 | 80/7.4 | Intensity (center) Lux/Footcandles |
| Green | 7438/691 | 4760/442 | 1859/173 | 826/77 | 464/43 | 298/28 | 207/19 | 152/14 | |
| Blue | 1672/155 | 1070/99 | 418/39 | 186/17 | 105/10 | 66/6 | 46/4 | 34/3 | |
| White | 9422/875 | 6030/560 | 2355/219 | 1046/97 | 588/55 | 377/35 | 262/24 | 192/18 | |
| R+G+B+W | 18797/1746 | 12030/1118 | 4700/437 | 2088/194 | 1174/109 | 752/70 | 522/49 | 384/36 | |

Illuminance distribution

Distance=5m

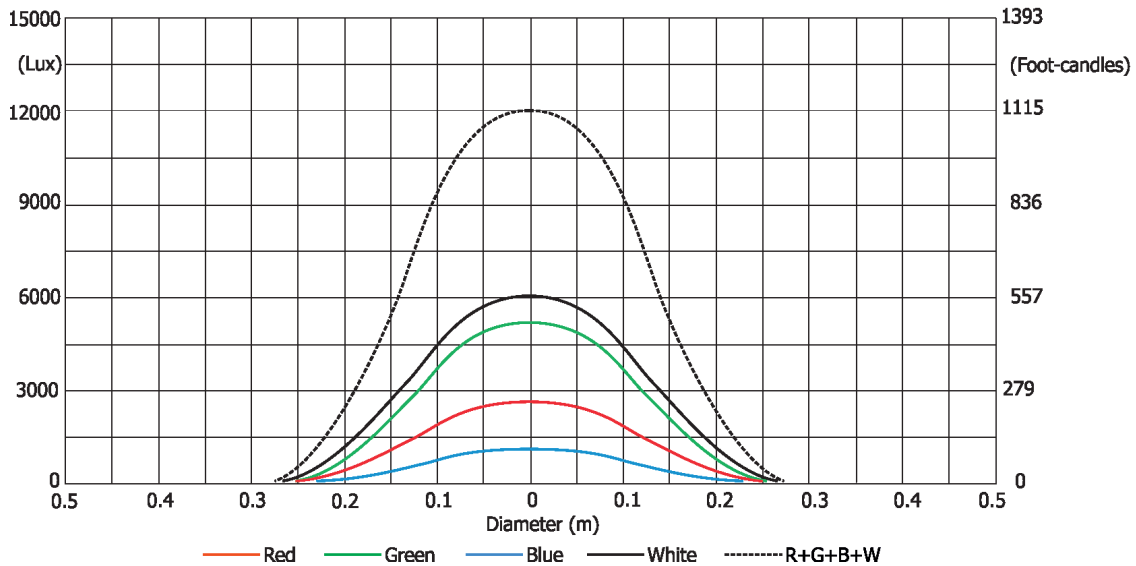

Max. Zoom

Total Output: 2842 lumens

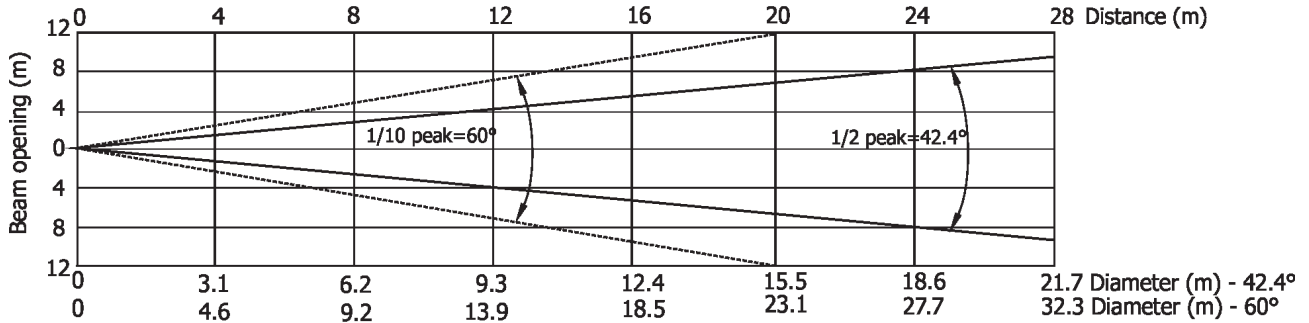

| Distance (m) | 4 | 5 | 8 | 12 | 16 | 20 | 24 | 28 | |
|--------------|--------|----------|--------|--------|--------|---------|-------|---------|---------------------------------------|
| Red | 87/5 | 56/5 | 22/2 | 10/0.9 | 6/0.5 | 4/0.3 | 2/0.2 | 2/0.2 | Intensity (center) Lux/Footcandles |
| Green | 168/10 | 108/10 | 42/4 | 19/1.7 | 11/1 | 6.8/0.6 | 5/0.4 | 3/0.3 | |
| Blue | 36/3 | 23/2 | 9/0.8 | 4/0.4 | 2/0.2 | 1.4/0.1 | 1/0.1 | 0.7/0.1 | |
| White | 209/20 | 134/12.4 | 52/5 | 23/2 | 13/1 | 8/0.7 | 6/0.5 | 4/0.4 | |
| R+G+B+W | 417/39 | 267/25 | 104/10 | 46/4 | 26/2.4 | 17/1.6 | 12/1 | 9/0.8 | |

Illuminance distribution

Distance=5m

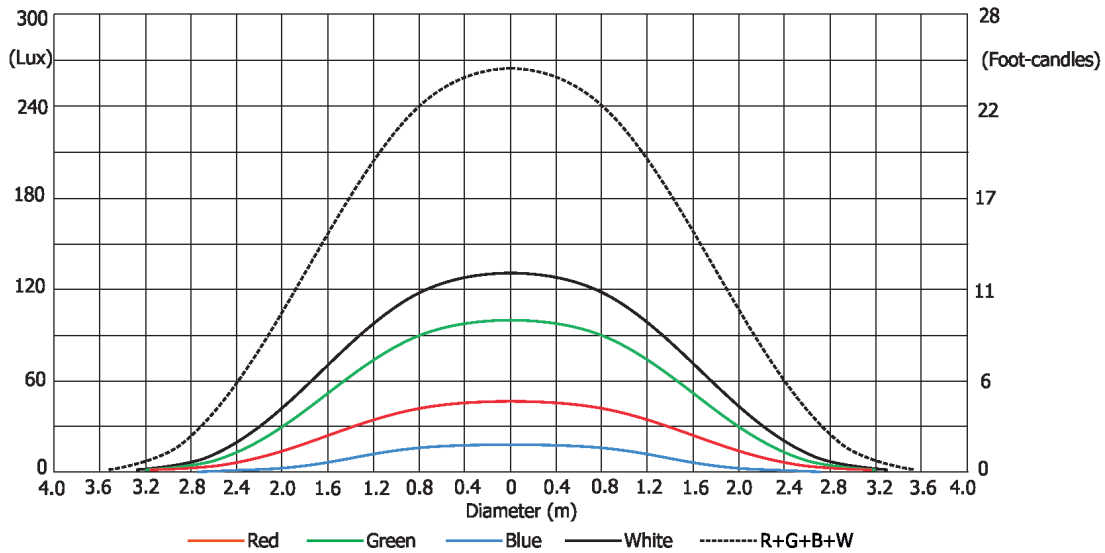

Max. Zoom (with EggCrate)

Total Output: 2614 lumens

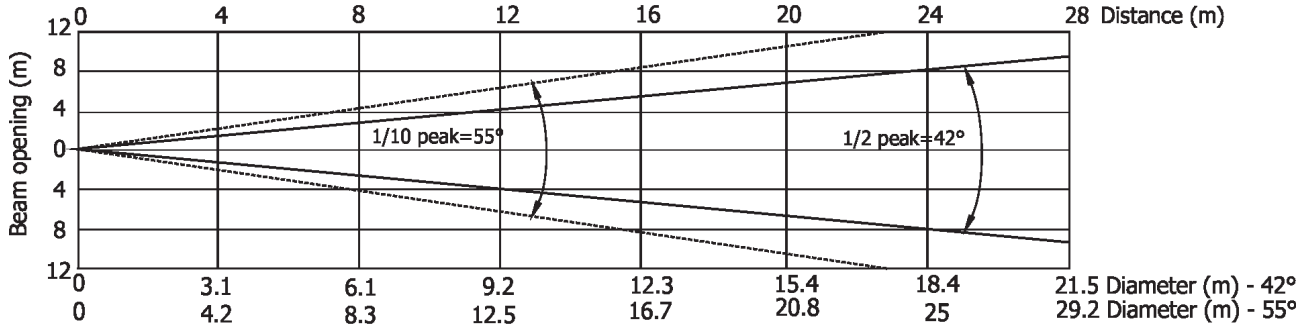

| Distance (m) | 4 | 5 | 8 | 12 | 16 | 20 | 24 | 28 | |
|--------------|--------|--------|-------|--------|--------|---------|-------|---------|---------------------------------------|
| Red | 78/7 | 50/5 | 20/2 | 9/0.8 | 5/0.5 | 3/3.1 | 2/0.2 | 2/0.1 | Intensity (center) Lux/Footcandles |
| Green | 163/15 | 104/10 | 41/4 | 18/1.7 | 10/0.9 | 7/0.6 | 5/0.4 | 3/0.3 | |
| Blue | 34/3 | 22/2 | 9/0.8 | 4/0.4 | 2/0.2 | 1.4/0.1 | 1/0.1 | 0.7/0.1 | |
| White | 195/18 | 125/12 | 49/5 | 22/2 | 12/1 | 8/0.7 | 5/0.5 | 4/0.4 | |
| R+G+B+W | 375/35 | 240/22 | 94/9 | 42/4 | 23/2 | 15/1.4 | 10/1 | 7/0.7 | |

Illuminance distribution

Distance=5m

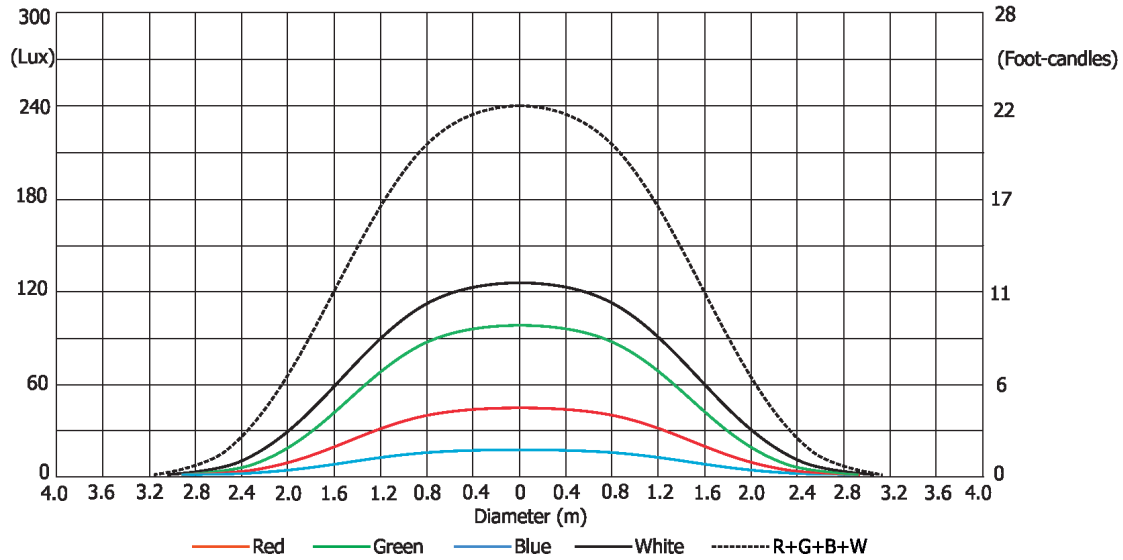

10.2 ROBIN Perfect 150 FW

Min. Zoom

Total Output: 1136 lumens

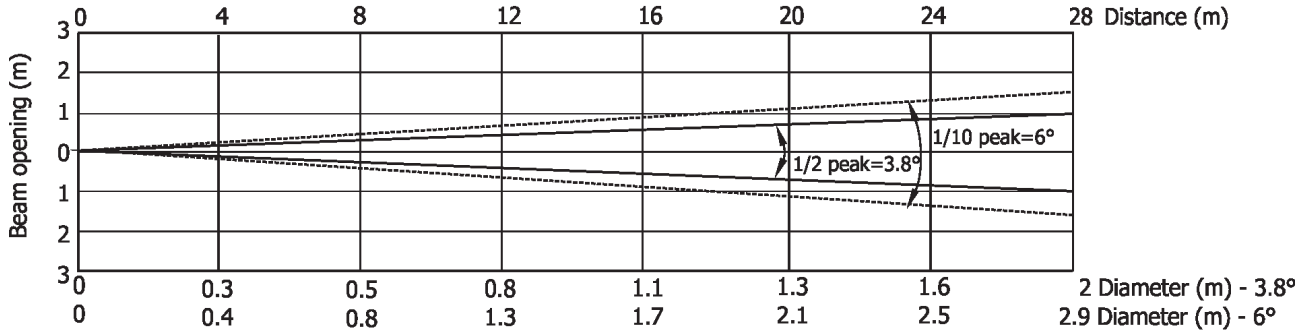

| Distance (m) | 4 | 5 | 8 | 12 | 16 | 20 | 24 | 28 | |
|--------------|------------|----------|----------|----------|--------|--------|--------|--------|---------------------------------------|
| Red | 2609/242 | 1670/155 | 652/61 | 290/27 | 163/15 | 104/10 | 73/7 | 53/5 | Intensity (center) Lux/Footcandles |
| Green | 6000/557 | 3840/357 | 1500/139 | 666/62 | 375/35 | 240/22 | 166/16 | 122/11 | |
| Blue | 875/82 | 560/52 | 219/20 | 97/9 | 55/5 | 35/3.3 | 24/2.3 | 18/1.7 | |
| White | 7234/672 | 4630/430 | 1809/168 | 803/75 | 452/42 | 289/27 | 201/19 | 147/14 | |
| R+G+B+W | 12797/1189 | 8190/761 | 3200/297 | 1422/132 | 800/74 | 511/48 | 355/33 | 261/24 | |

Illuminance distribution

Distance=5m

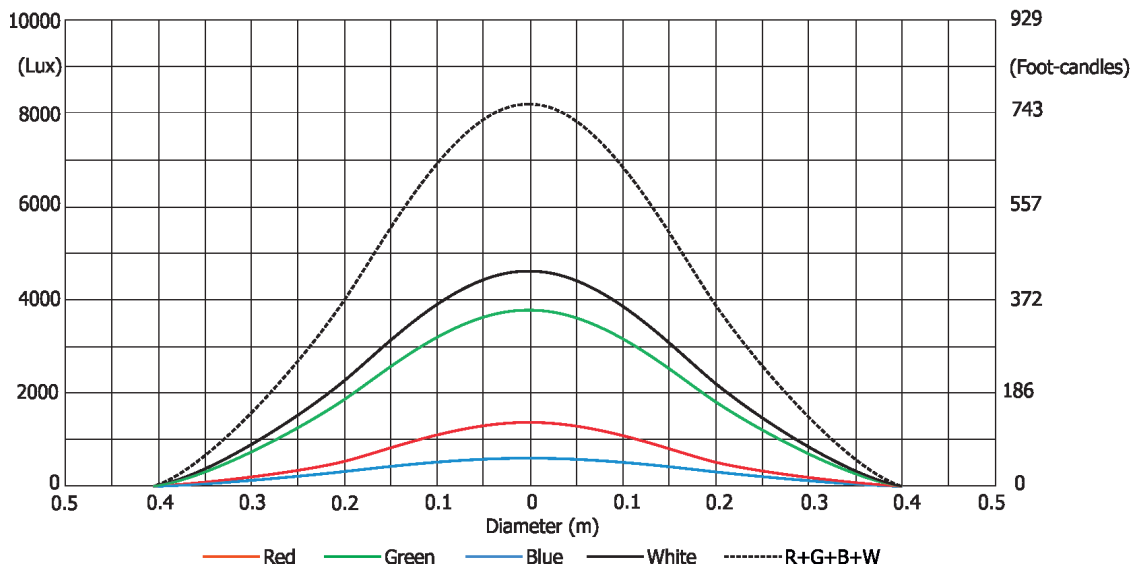

Max. Zoom

Total Output: 2288 lumens

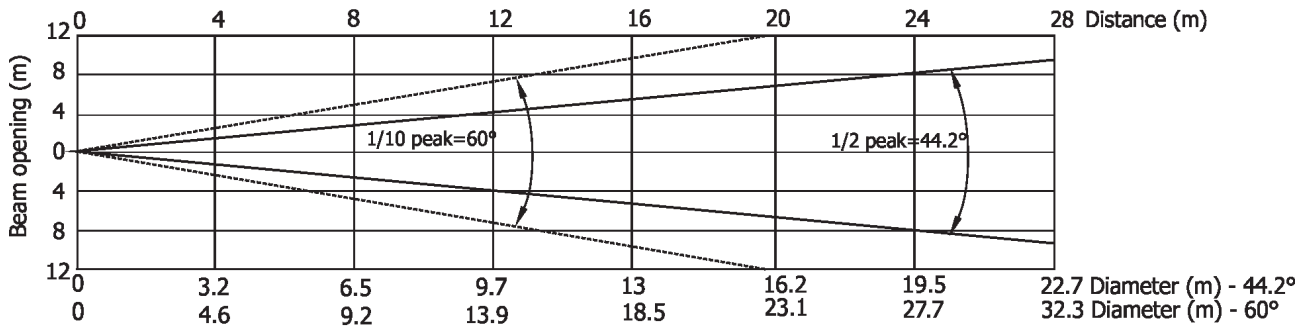

| Distance (m) | 4 | 5 | 8 | 12 | 16 | 20 | 24 | 28 | |
|--------------|--------|--------|--------|---------|----------|---------|---------|----------|---------------------------------------|
| Red | 73/6.8 | 47/4.4 | 18/1.7 | 8/0.8 | 5/0.4 | 3/0.3 | 2/0.2 | 1.5/0.1 | Intensity (center) Lux/Footcandles |
| Green | 148/14 | 95/9 | 37/3.4 | 17/1.5 | 9/1 | 6/0.6 | 4/0.4 | 3/0.3 | |
| Blue | 20/2 | 13/1.2 | 5/0.5 | 2.3/0.2 | 1.3/0.1 | 0.8/0.1 | 0.6/0.1 | 0.4/0.08 | |
| White | 181/17 | 116/11 | 45/4.2 | 20/1.9 | 11.3/1.1 | 7/0.7 | 5/0.5 | 4/0.3 | |
| R+G+B+W | 333/31 | 215/20 | 84/8 | 37/3.5 | 21/2 | 13/1.2 | 9/1 | 7/0.6 | |

Illuminance distribution

Distance=5m

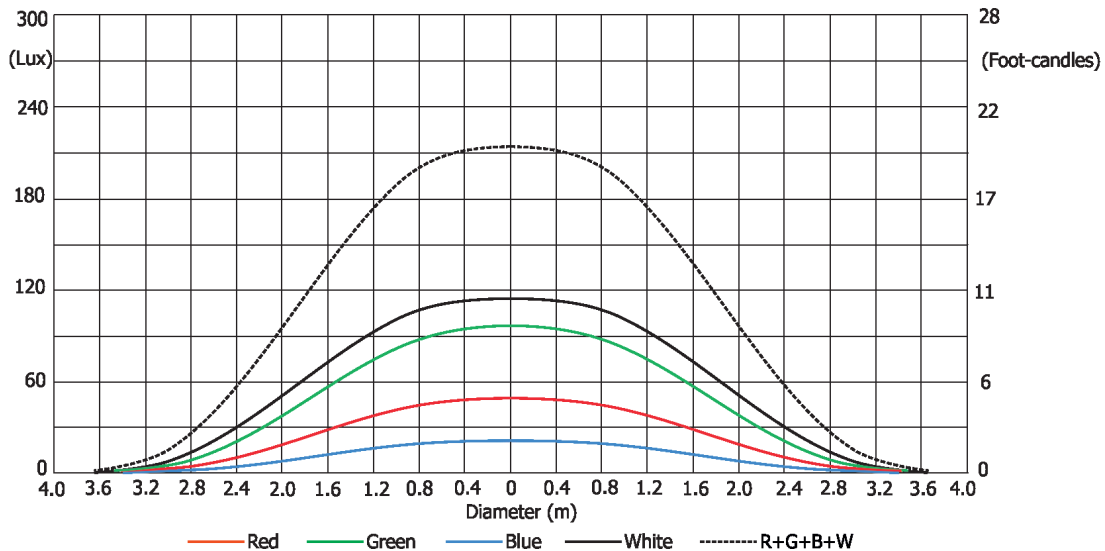

Copyright © 2017-2018 Robe Lighting - All rights reserved

Specifications are subject to change without notice.

January 16, 2018

Made in ROBE Lighting s.r.o., Palackého 416, 757 01 Valašské Meziříčí, Czech Republic

11. ChangeLog

This section summarizes all types of changes in the user manual.

| Version of the manual | Date of issue | Description of changes |
|------------------------------|----------------------|---|
| 1.1 | 14/05/2017 | EggCrate installation added, DMX protocol ver.1.1 |
| 1.2 | 07/06/2017 | Quiet mode for fan in menu Personality, DMX protocol ver. 1.2 |
| 1.3 | 30/10/2017 | Accessory frame safety wire added |
| 1.4 | 16/01/2018 | Optional accessories changed |
| 1.5 | 27/03/2018 | Added installation of 2° Diffuser |

DMX protocol

| Robin Parfect 150/Robin Parfect 150FW - DMX protocol | | | | |
|--|---|-----------|---|-----------------|
| Version: 1.2 Mode 1-Standard 16-bit, Mode 2 -Reduced 8-bit | | | | |
| Mode/channel | | DMX Value | Function | Type of control |
| 1 | 2 | | | |
| 1 | 1 | | Power/Special functions | |
| | | 0 -19 | Reserved (0=default) <i>To activate following functions, stop in DMX value for at least 3 s and shutter must be closed at least 3 sec. („Shutter,Strobe“ channel 20/15 must be at range: 0-31 DMX). Corresponding menu items are temporarily overridden.</i> | |
| | | 20-24 | Display ON | step |
| | | 25-29 | Display OFF | step |
| | | 30-34 | RGBW colour mixing mode | step |
| | | 35-39 | CMY colour mixing mode | step |
| | | 40-59 | Reserved | |
| | | 60 - 64 | Dimmer curve - square law | step |
| | | 65 - 69 | Dimmer curve - linear | step |
| | | 70 - 74 | Fan mode: Auto | step |
| | | 75 - 79 | Fan mode: High | step |
| | | 80-84 | White point 8000K ON | step |
| | | 85-89 | White point 8000K OFF | step |
| | | 90-94 | Fan mode: Quiet | step |
| | | 95 -129 | Reserved | |
| | | | <i>To activate following functions, stop in DMX value for at least 3 seconds.</i> | |
| | | 130 - 149 | Reserved | |
| | | 150 - 159 | Zoom reset | step |
| | | 160 - 169 | Reserved | |
| | | | <i>Tungsten effect simulation for whites 2700K and 3200K</i> | |
| | | 170-171 | Tungsten effect simulation (750W) On | step |
| | | 172-173 | Tungsten effect simulation (1000W) On | step |
| | | 174-175 | Tungsten effect simulation (1200W) On | step |
| | | 176-177 | Tungsten effect simulation (2000W) On | step |
| | | 178-179 | Tungsten effect simulation (2500W) On | step |
| | | 180-181 | Tungsten effect simulation Off | step |
| | | 182-255 | Reserved | |
| 2 | 2 | | Virtual colour wheel | |
| | | 0 | No function (0=default) | step |
| | | 1-2 | Filter 4 (Medium Bastard Amber) | step |
| | | 3-4 | Filter 25 (Sunset Red) | step |
| | | 5-6 | Filter 19 (Fire) | step |
| | | 7-8 | Filter 26 (Bright Red) | step |
| | | 9-10 | Filter 58 (Lavender) | step |
| | | 11-12 | Filter 68 (Sky Blue) | step |
| | | 13-14 | Filter 36 (Medium Pink) | step |
| | | 15-16 | Filter 89 (Moss Green) | step |
| | | 17-18 | Filter 88 (Lime Green) | step |
| | | 19-20 | Filter 90 (Dark Yellow Green) | step |
| | | 21-22 | Filter 49 (Medium Purple) | step |
| | | 23-24 | Filter 52 (Light Lavender) | step |
| | | 25-26 | Filter 102 (Light Amber) | step |

DMX protocol

| Mode/channel | | DMX Value | Function | Type of control |
|--------------|---|-----------|--|-----------------|
| 1 | 2 | | | |
| | | 27-28 | Filter 103 (Straw) | step |
| | | 29-30 | Filter 140 (Summer Blue) | step |
| | | 31-32 | Filter 124 (Dark Green) | step |
| | | 33-34 | Filter 106 (Primary Red) | step |
| | | 35-36 | Filter 111 (Dark Pink) | step |
| | | 37-38 | Filter 115 (Peacock Blue) | step |
| | | 39-40 | Filter 126 (Mauve) | step |
| | | 41-42 | Filter 117 (Steel Blue) | step |
| | | 43-44 | Filter 118 (Light Blue) | step |
| | | 45-46 | Filter 122 (Fern Green) | step |
| | | 47-48 | Filter 182 (Light Red) | step |
| | | 49-50 | Filter 121 (Filter Green) | step |
| | | 51-52 | Filter 128 (Bright Pink) | step |
| | | 53-54 | Filter 131 (Marine Blue) | step |
| | | 55-56 | Filter 132 (Medium Blue) | step |
| | | 57-58 | Filter 134 (Golden Amber) | step |
| | | 59-60 | Filter 135 (Deep Golden Amber) | step |
| | | 61-62 | Filter 136 (Pale Lavender) | step |
| | | 63-64 | Filter 137 (Special Lavender) | step |
| | | 65-66 | Filter 138 (Pale Green) | step |
| | | 67-68 | Filter 798 (Chrysalis Pink) | step |
| | | 69-70 | Filter 141 (Bright Blue) | step |
| | | 71-72 | Filter 147 (Apricot) | step |
| | | 73-74 | Filter 148 (Bright Rose) | step |
| | | 75-76 | Filter 152 (Pale Gold) | step |
| | | 77-78 | Filter 154 (Pale Rose) | step |
| | | 79-80 | Filter 157 (Pink) | step |
| | | 81-82 | Filter 143 (Pale Navy Blue) | step |
| | | 83-84 | Filter 162 (Bastard Amber) | step |
| | | 85-86 | Filter 164 (Flame Red) | step |
| | | 87-88 | Filter 165 (Daylight Blue) | step |
| | | 89-90 | Filter 169 (Lilac Tint) | step |
| | | 91-92 | Filter 170 (Deep Lavender) | step |
| | | 93-94 | Filter 172 (Lagoon Blue) | step |
| | | 95-96 | Filter 194 (Surprise Pink) | step |
| | | 97-98 | Filter 180 (Dark Lavender) | step |
| | | 99-100 | Filter 181 (Congo Blue) | step |
| | | 101-102 | Filter 197 (Alice Blue) | step |
| | | 103-104 | Filter 201 (Full C.T. Blue) | step |
| | | 105-106 | Filter 202 (Half C.T. Blue) | step |
| | | 107-108 | Filter 203 (Quarter C.T. Blue) | step |
| | | 109-110 | Filter 204 (Full C.T. Orange) | step |
| | | 111-112 | Filter 219 (Fluorescent Green) | step |
| | | 113-114 | Filter 206 (Quarter C.T. Orange) | step |
| | | 115-116 | Filter 247 (Filter Minus Green) | step |
| | | 117-118 | Filter 248 (Half Minus Green) | step |
| | | 119-120 | Filter 281 (Three Quarter C.T. Blue) | step |
| | | 121-122 | Filter 285 (Three Quarter C.T. Orange) | step |
| | | 123-124 | Filter 352 (Glacier Blue) | step |

DMX protocol

| Mode/channel | | DMX Value | Function | Type of control |
|--------------|----------|-----------|--|-----------------|
| 1 | 2 | | | |
| | | 125-126 | Filter 353 (Lighter Blue) | step |
| | | 127-128 | Filter 507 (Madge) | step |
| | | 129-130 | Filter 778 (Millennium Gold) | step |
| | | 131-132 | Filter 793 (Vanity Fair) | step |
| | | 133-235 | Raw DMX | proportional |
| | | 236-245 | Rainbow effect (with fade time) from slow-> fast | proportional |
| | | 246-255 | Rainbow effect (without fade time) from slow-> fast | proportional |
| 3 | 3 | | Red/Cyan (8 bit)* | |
| | | 0 - 255 | Colour saturation control - coarse 0-100% (255=default) | proportional |
| 4 | * | | Red/Cyan (16bit)* | |
| | | 0 - 255 | Colour saturation control - fine (255=default) | proportional |
| 5 | 4 | | Green/Magenta (8 bit) * | |
| | | 0 - 255 | Colour saturation control - coarse 0-100% (255=default) | proportional |
| 6 | * | | Green/Magenta (16bit) * | |
| | | 0 - 255 | Colour saturation control - fine (255=default) | proportional |
| 7 | 5 | | Blue/Yellow (8 bit) * | |
| | | 0 - 255 | Colour saturation control - coarse 0-100% (255=default) | proportional |
| 8 | * | | Blue/ Yellow (16bit) * | |
| | | 0 - 255 | Colour saturation control - fine (255=default) | proportional |
| 9 | 6 | | White (8 bit) | |
| | | | <i>If RGBW mode is selected:</i> | |
| | | 0-255 | Colour saturation control - coarse 0-100% (255=default) | proportional |
| | | | <i>If CMY mode is selected:</i> | |
| | | 0 - 255 | No function | |
| 10 | * | | White (16 bit) | |
| | | 0 - 255 | Colour saturation control - fine (255=default) | proportional |
| 11 | 7 | | CTC | |
| | | | <i>If function "White Point 8000K" is ON</i> | |
| | | 0-255 | Col. temperature correction from 8000K to 2700K -for whites only (0=8000K, 64=5600K, 128=4200K, 192=3200K, 255=2700K) To get colour temperatures stated above, RGBW channels have to be set at the same value e.g. 255DMX (0=default) (To activate Tungsten effect at 2700K and 3200K , set DMX value at "Power/Special functions" channel) | proportional |
| | | | <i>If function "White Point 8000K" is OFF</i> | |
| | | 0-255 | Colour temperature correction for from cool white to 2700K | proportional |
| 12 | 8 | | Colour Mix control | |
| | | | <i>Defines relation between colour channels</i> | |
| | | | "Virtual" = Virtual Colours (Virtual Colour Wheel) | |
| | | | "Colour mix" = Colour channels (RGBW/CMY) | |
| | | 0-9 | Virtual colors ("Virtual" has priority) | step |
| | | 10-19 | Maximum mode (highest values have priority) | step |
| | | 20-29 | Minimum mode (lowest values have priority) | step |
| | | 30-39 | Multiply mode (multiply Virtual and Colour Mix) | step |
| | | 40-49 | Addition mode (Virtual + Colour mix) (45=default) | step |
| | | 50-59 | Subtraction mode (Virtual – Colour mix) | step |
| | | 60-69 | Inverted Subtraction mode (Virtual – Colour mix) | step |
| | | 70-128 | Reserved | |
| | | 129 | Virtual colors (virtual has priority) | step |

DMX protocol

| Mode/channel | | DMX Value | Function | Type of control |
|---|-----------|-----------|--|-----------------|
| 1 | 2 | | | |
| | | 130-254 | Crossfade (crossfade between Virtual and Colour mix) | proportional |
| | | 255 | Colour channels ("Colour mix" has priority) | step |
| 13 | 9 | | Zoom | |
| | | 0-255 | Zoom from max. to min.beam angle (128=default) | proportional |
| 14 | * | | Zoom - fine | |
| | | 0-255 | Fine zooming (0=default) | proportional |
| 15 | 10 | | Shutter/ strobe | |
| | | 0 - 31 | Shutter closed | step |
| | | 32 - 63 | Shutter open (32=default) | step |
| | | 64 - 95 | Strobe-effect from slow to fast | proportional |
| | | 96 - 127 | Shutter open | step |
| | | 128 - 143 | Opening pulse in sequences from slow to fast | proportional |
| | | 144 - 159 | Closing pulse in sequences from fast to slow | proportional |
| | | 160 - 191 | Shutter open | step |
| | | 192 - 223 | Random strobe-effect from slow to fast | proportional |
| | | 224 - 255 | Shutter open | step |
| 16 | 11 | | Dimmer intensity (8 bit) | |
| | | 0 - 255 | Dimmer intensity from 0% to 100% (0=default) | proportional |
| 17 | * | | Dimmer intensity - fine (16 bit) | |
| | | 0 - 255 | Fine dimming (0=default) | proportional |
| *Select RGB or CMY mixing mode on channel "Power/Special functions" . | | | | |
| Copyright © 2017 Robe Lighting s.r.o. - All rights reserved | | | | |
| All Specifications subject to change without notice | | | | |

| Robin LEDBeam 150/Parfect 150/Parfect 150 FW - colours on Virtual Colour Wheel | | | | |
|---|----------------------|------------------------|-----------------------|------------------------|
| Colour name | Red (DMX) | Green (DMX) | Blue (DMX) | White (DMX) |
| Filter 4 (Medium Bastard Amber) | 255 | 118 | 0 | 109 |
| Filter 25 (Sunset Red) | 255 | 47 | 0 | 3 |
| Filter 19 (Fire) | 255 | 13 | 0 | 0 |
| Filter 26 (Bright Red) | 255 | 0 | 0 | 0 |
| Filter 58 (Lavender) | 117 | 0 | 97 | 155 |
| Filter 68 (Sky Blue) | 31 | 219 | 105 | 6 |
| Filter 36 (Medium Pink) | 255 | 74 | 8 | 24 |
| Filter 89 (Moss Green) | 69 | 245 | 0 | 3 |
| Filter 88 (Lime Green) | 187 | 226 | 0 | 0 |
| Filter 90 (Dark Yellow Green) | 2 | 255 | 0 | 0 |
| Filter 49 (Medium Purple) | 255 | 0 | 27 | 0 |
| Filter 52 (Light Lavender) | 232 | 88 | 6 | 166 |
| Filter 102 (Light Amber) | 223 | 164 | 0 | 0 |
| Filter 103 (Straw) | 191 | 144 | 0 | 28 |
| Filter 140 (Summer Blue) | 0 | 149 | 3 | 220 |
| Filter 124 (Dark Green) | 29 | 255 | 0 | 12 |
| Filter 106 (Primary Red) | 242 | 1 | 1 | 0 |
| Filter 111 (Dark Pink) | 255 | 67 | 11 | 49 |
| Filter 115 (Peacock Blue) | 0 | 255 | 29 | 43 |
| Filter 126 (Mauve) | 255 | 0 | 39 | 0 |
| Filter 117 (Steel Blue) | 179 | 255 | 14 | 197 |
| Filter 118 (Light Blue) | 0 | 255 | 76 | 30 |
| Filter 122 (Fern Green) | 98 | 255 | 0 | 4 |
| Filter 182 (Light Red) | 255 | 16 | 2 | 0 |
| Filter 121 (Filter Green) | 165 | 255 | 0 | 0 |
| Filter 128 (Bright Pink) | 255 | 0 | 13 | 32 |
| Filter 131 (Marine Blue) | 73 | 245 | 27 | 30 |
| Filter 132 (Medium Blue) | 0 | 230 | 120 | 0 |
| Filter 134 (Golden Amber) | 166 | 83 | 0 | 0 |
| Filter 135 (Deep Golden Amber) | 255 | 50 | 0 | 0 |
| Filter 136 (Pale Lavender) | 140 | 101 | 25 | 40 |
| Filter 137 (Special Lavender) | 110 | 60 | 45 | 102 |
| Filter 138 (Pale Green) | 241 | 255 | 4 | 48 |
| Filter 798 (Chrysalis Pink) | 49 | 0 | 98 | 26 |
| Filter 141 (Bright Blue) | 0 | 225 | 62 | 5 |
| Filter 147 (Apricot) | 190 | 107 | 0 | 15 |
| Filter 148 (Bright Rose) | 255 | 3 | 0 | 37 |
| Filter 152 (Pale Gold) | 179 | 119 | 0 | 39 |
| Filter 154 (Pale Rose) | 214 | 118 | 0 | 48 |
| Filter 157 (Pink) | 255 | 56 | 5 | 43 |
| Filter 143 (Pale Navy Blue) | 0 | 193 | 67 | 148 |
| Filter 162 (Bastard Amber) | 211 | 153 | 6 | 36 |
| Filter 164 (Flame Red) | 255 | 27 | 0 | 4 |
| Filter 165 (Daylight Blue) | 23 | 236 | 93 | 81 |
| Filter 169 (Lilac Tint) | 185 | 123 | 0 | 109 |
| Filter 170 (Deep Lavender) | 235 | 123 | 41 | 37 |
| Filter 172 (Lagoon Blue) | 0 | 255 | 63 | 5 |

| Colour name | Red (DMX) | Green (DMX) | Blue (DMX) | White (DMX) |
|--|----------------------|------------------------|-----------------------|------------------------|
| Filter 194 (Surprise Pink) | 110 | 0 | 21 | 255 |
| Filter 180 (Dark Lavender) | 136 | 43 | 181 | 120 |
| Filter 181 (Congo Blue) | 24 | 0 | 255 | 9 |
| Filter 197 (Alice Blue) | 79 | 193 | 154 | 36 |
| Filter 201 (Full C.T. Blue) | 153 | 223 | 66 | 156 |
| Filter 202 (Half C.T. Blue) | 255 | 248 | 34 | 116 |
| Filter 203 (Quarter C.T. Blue) | 245 | 213 | 14 | 147 |
| Filter 204 (Full C.T. Orange) | 230 | 131 | 3 | 3 |
| Filter 219 (Fluorescent Green) | 99 | 148 | 16 | 50 |
| Filter 206 (Quarter C.T. Orange) | 199 | 152 | 0 | 60 |
| Filter 247 (Filter Minus Green) | 255 | 79 | 0 | 187 |
| Filter 248 (Half Minus Green) | 255 | 138 | 0 | 112 |
| Filter 281 (Three Quarter C.T. Blue) | 225 | 255 | 99 | 189 |
| Filter 285 (Three Quarter C.T. Orange) | 181 | 121 | 0 | 15 |
| Filter 352 (Glacier Blue) | 0 | 161 | 49 | 90 |
| Filter 353 (Lighter Blue) | 0 | 115 | 21 | 97 |
| Filter 507 (Madge) | 255 | 31 | 0 | 0 |
| Filter 778 (Millennium Gold) | 255 | 65 | 0 | 0 |
| Filter 793 (Vanity Fair) | 255 | 0 | 13 | 16 |
| | | | | |