

# Instruction Manual

impression<sup>®</sup>  
X4 XL



from software version: v1.47



— since 1994 —

support@glp.de  
www.glp.de



## Table of contents

<b>1</b>	<b>Description of Device</b> .....	<b>4</b>
<b>2</b>	<b>Safety Instructions</b> .....	<b>5</b>
<b>3</b>	<b>Mounting</b> .....	<b>7</b>
	3.1.1 <i>Mounting on the Floor (upright)</i> .....	8
	3.1.2 <i>Mounting in hanging position (Head down)</i> .....	9
	3.2 <b>Securing the Fixture</b> .....	9
	3.3 <b>Connections</b> .....	10
	3.3.1 <i>Power Supply</i> .....	10
	3.3.2 <i>DMX</i> .....	10
<b>4</b>	<b>The Menu Field</b> .....	<b>10</b>
<b>5</b>	<b>DMX Channel Selection (DMX Protocol)</b> .....	<b>13</b>
	5.1 <b>Normal-Mode (26 DMX channels)</b> .....	13
	5.2 <b>Compress-Mode (16 DMX channels)</b> .....	16
	5.3 <b>High Resolution/Extended-Mode (27 DMX Channels)</b> .....	18
<b>6</b>	<b>Maintaining and Cleaning</b> .....	<b>21</b>
	6.1 <b>Safety regulations</b> .....	21
	6.2 <b>Maintenance and Interval (rule-of-thumb)</b> .....	21
<b>7</b>	<b>Technical Specifications</b> .....	<b>22</b>
<b>8</b>	<b>Dimensions</b> .....	<b>23</b>
<b>9</b>	<b>Index</b> .....	<b>24</b>

## 1 Description of Device

1. Moving head (actively and passively cooled)
2. Arm with various cooling vents
3. LCD-Display/Menu (data entry)
4. Base with various connectors and Camlock mounting system

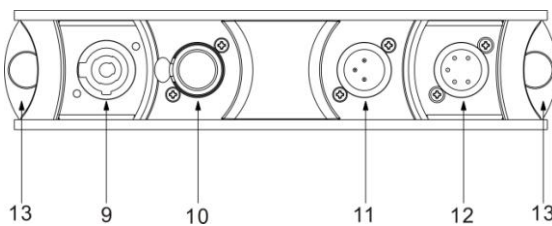
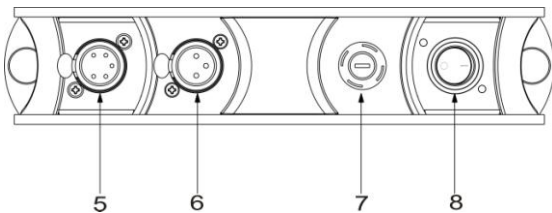
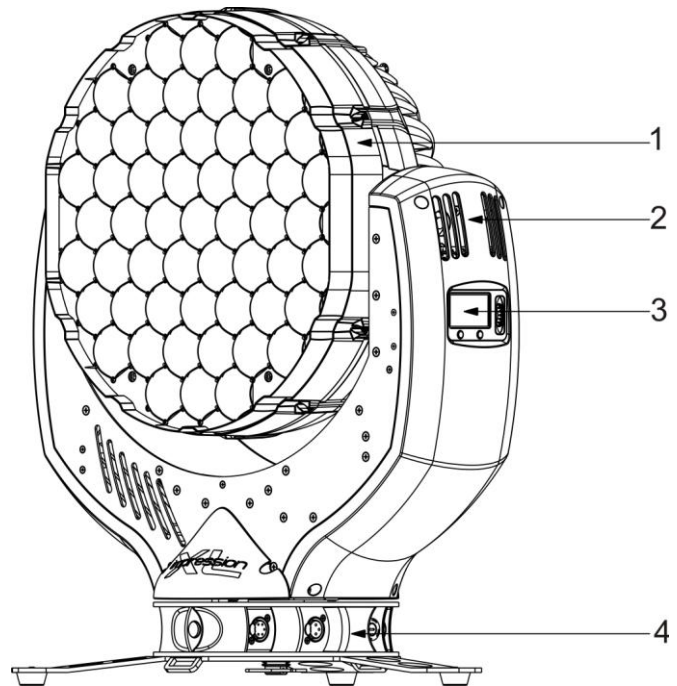

5. DMX- Output (5 pin)
6. DMX- Output (3 pin)
7. Micro-fuse: 5 x 20mm, T12A
8. Power Switch
9. Neutrik Powercon (Mains power input)
10. Blank panel (primed for Ethernet)
11. DMX- Input (3 pin)
12. DMX- Input (5 pin)
13. 2x Safety wire points

**Note:** Only connect one cable to the DMX Input / Output at the same time!

## 2 Safety Instructions



The **IMPRESSION X4 XL** is a High-Tech Product. To guarantee a smooth operation, it is necessary to respect the following rules. The manufacturer of this device will not take responsibility for damages through any disregard of the information provided in this manual. Warranty claims also will be voided in the case that the fixture housing is opened.



**Never look directly into the beam of light or into one of the LEDs.** **Attention:** LED Class 2M can cause injuries of your eyes even without optical instruments in front of them or within a distance of less than 0.5m and short exposure time.  
Hence: Avoid direct radiation into your eyes!



**WARNING:**

**Never let optical parts come in contact with alcohol, solvents or similar cleaners.**

1. Before powering on the fixture, make sure that the fixtures fans and air inlets are clean and not blocked.
2. Ensure that the fixture head can rotate unhindered throughout its complete range of pan and tilt movement. A safety distance of at least 0.5 m must be maintained between the fixture and any easily inflammable material.
3. **Attention!** Don't touch the fixture during the operation. This can cause injuries and/or damages.
4. **The fixture doesn't contain any user serviceable parts. Opening the fixture will void all warranties.**
5. It is necessary to wait at least 15 minutes after disconnecting the mains power before handling the fixture. Pay attention to possible hot parts.
6. To ensure safe operation, follow also the Installation guide described in the chapter below. Operating the **IMPRESSION X4 XL** without suitable safety aids like Safety cables or clamps/hooks can increase the risk of an accident and must be avoided.
7. Repair, maintenance, and installation work shall be done by qualified or GLP certified staff only. You need to pay attention to the common rules of technology that are not explicitly mentioned in this manual.
8. Use only original GLP spare parts. Any structural modification of the system will terminate all warranty claims.
9. Please keep this instruction manual for future reference.



## Important Safety Information

The **IMPRESSION X4XL** fixture from GLP is fitted with a number of plano-convex lenses in a highly efficient collimator cluster. This type of lens can act as a strong magnifying glass.

If the rays from a strong light source (such as the sun or another lighting fixture) are directed towards the front of any of these fixtures, then internal damage may occur. In a worst case scenario with a high power light source this can happen very quickly, damaging the fixture internally, potentially melting components or causing an internal fire within seconds.

In order to avoid these possible problems please adhere to the following requirements:

- **Do not expose the front of a fixture to direct sunlight or any other strong light sources.**
- **For outdoor applications during daylight make sure that the front face of any fixture is either shielded or points away from the sun, even when fixtures are not in use.**
- **Do not modify the front glass or lenses of any fixture.**

These requirements have to be followed regardless of whether a fixture is powered on or off as the magnifying effect is an optical effect and therefore independent from the (electrical) state of the fixture.

Especially when working with high powered **beam-lights**; extreme caution and observance of these safety instructions is mandatory.

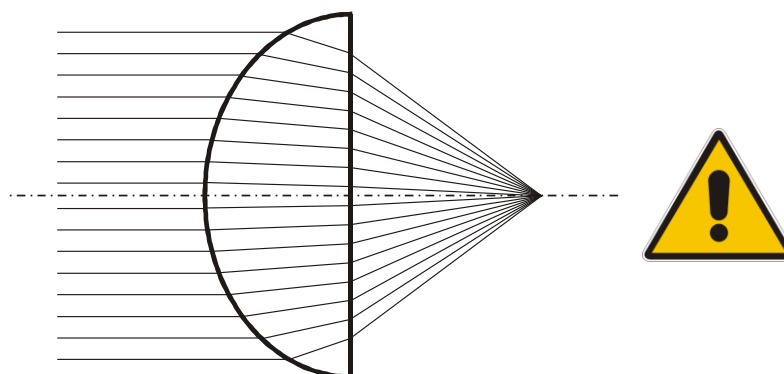

Should you have any questions about the operation of your fixture then please contact your local GLP office, or their authorized distributor, a list of which can be found at [www.glp.de](http://www.glp.de).

### 3 Mounting

The **IMPRESSION X4XL** is fully operational whether it hangs or is mounted to the wall. It can also be operated while standing on the floor. Keep a safety distance of min. 0.5 m towards any easily inflammable materials (decoration etc.).

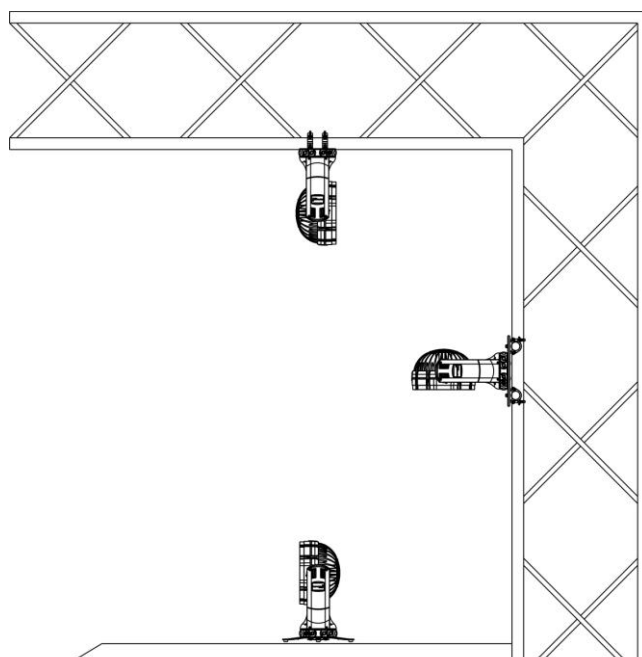

**Pay attention to the regulations of: BGV C1 (former VBG 70) and DIN VDE 0711-217.**

**The installation shall be done by qualified staff only.**

For the various mounting positions of the **IMPRESSION X4XL** (standing on the floor, sideways or hanging) different accessories kits are available. Through this a safe and firm installation is assured. You'll find dedicated connectors on the bottom side of the fixture which should be used. In addition the base is marked with a **FRONT** arrow allowing consistent orientation during installation.

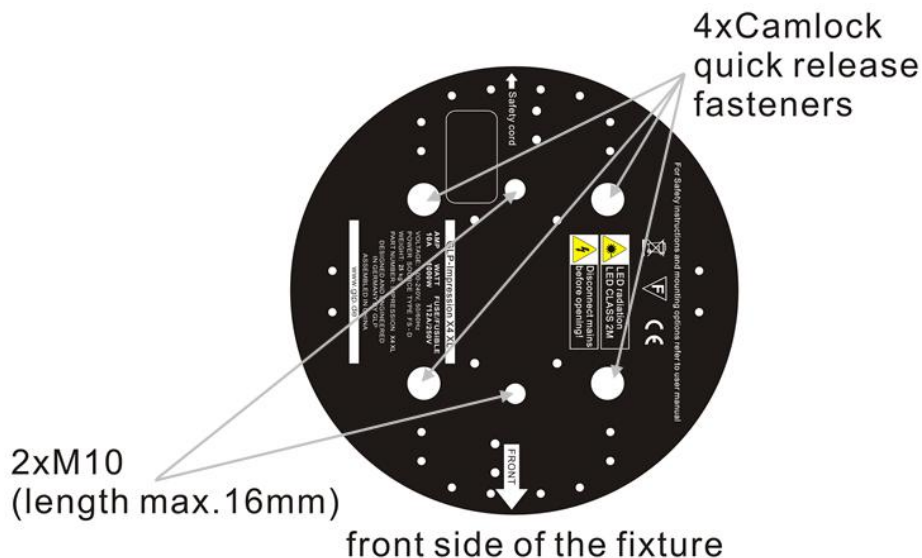

### 3.1.1 Mounting on the Floor (upright)

To operate the **IMPRESSION X4XL** in an upright position, please use the dedicated tri-legged floor stand supplied with your fixture. It is fixed to the base of the fixture with fasteners called Camlock quick-release connectors. Insert the two fasteners and turn each 90° to lock them. Do the opposite to release them again. On both sides you'll find eyelets to pull through a fixing strap. This allows for additional bracing of the fixture.

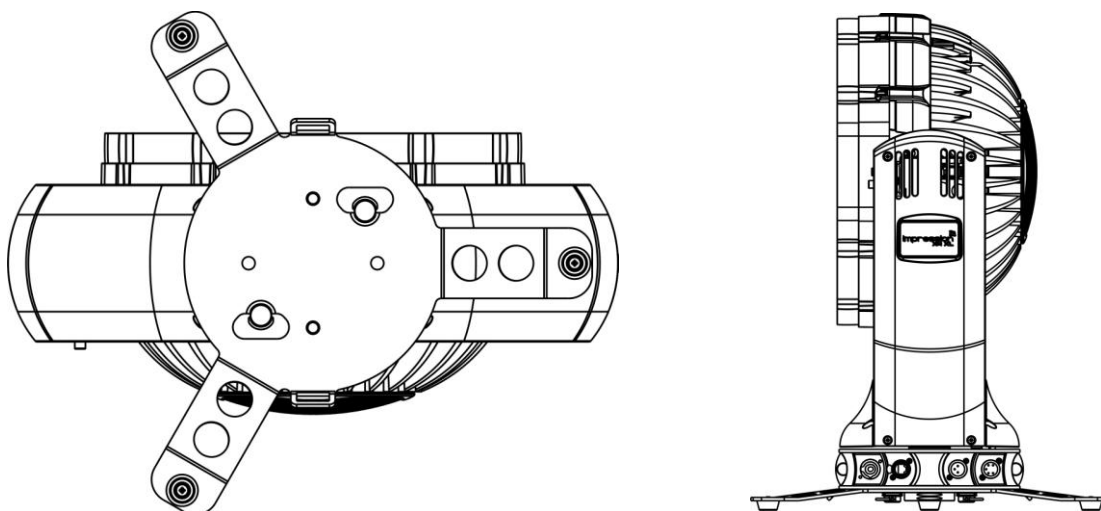



### 3.1.2 Mounting in hanging position (Head down)

To operate the **IMPRESSION X4XL** in a hanging position two (2) omega brackets can be mounted directly to the bottom of the base using the four (4) Camlock connectors.

Alternatively two half-couplers (clamps) can be mounted directly to the bottom side of the fixture using M10x16 mm thread bolts.

**Attention: Never use a longer bolt as this may damage the interior of the fixture.**

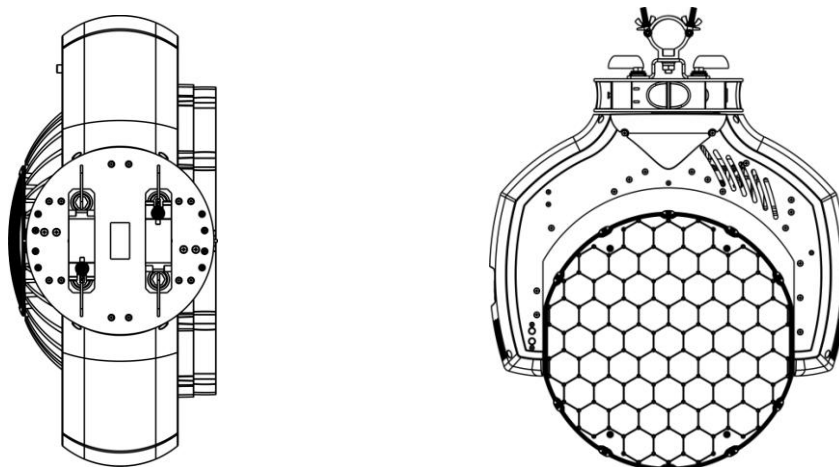

### 3.2 Securing the Fixture

Regardless of the mounting method of the **IMPRESSION X4XL** you'll have to use a stipulated safety wire. Attach the safety wire through one of the two holes provided on the base of the fixture and connect it to the primary support structure. Pay attention to a safe and proper fastening. The safety cable must comply with EN 60598-2-17 Section 17.6.6 and be capable of bearing a static suspended load that is ten times the weight of the fixture and all installed accessories.

### 3.3 Connections

#### 3.3.1 Power Supply

~100-240 Volt AC, 50-60 Hz, earth contact type plug - Powercon

Connected load 1200 VA (W) <=> T12A (micro-fuse 5x20mm)

Please see printing on the case for the right electronic supply!

**Disconnect from the mains supply for changing the fuse and use only the above described micro-fuse type.**

#### 3.3.2 DMX

USITT DMX-512 Standard input/output in 3/5 pin connectors.

Pin 1 = [Ground] / Pin 2 = [-] / Pin 3 = [+] / Pin 4&5 N.C.

The DMX- Addressing starts at the DMX- Address [001].

## 4 The Menu Field

You'll find the control board on the side part of the arm. It allows you to make all necessary adjustments of the **IMPRESSION X4XL**. With the **Mode**-key you get into the main menu. Afterwards you can navigate through the menu with the **Up/Down**-keys. Push the **Enter**-key to get in the next menu level or to confirm your settings. Make them and set functions **ON/OFF** with the **Up/Down**-keys. Confirm and save it with the **Enter**-key (the display shows **OK**). Push the **Mode**-key to cancel the entry and go back to the main menu.

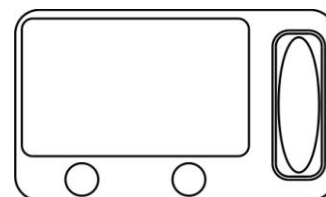

**To lock or unlock the keys of the menu field press Mode+Enter+Up simultaneously.**

← MODE - ENTER →

	Level1	Level 2	Level 3	Level 4	Remark
	DMX Start Address 001				Set the DMX start address
← DOWN - UP →	Special	Manual DMX			Manual control of all fixture functions
			Pan		Manual control for Pan (X-movement)
			Pattern Byte 3		Manual control for Pattern Byte 3 LED 17 -19
			Pattern Byte 2		Manual control for Pattern Byte 2 LED 9 - 16
			Pattern Byte 1		Manual control for Pattern Byte 1 LED 1 - 8
			Pattern		Manual control for Pattern channel / bank
			Zoom		Manual control for Zoom
			Speed Movements		Manual control for Pan/Tilt movements

← DOWN - UP →

	<b>Pan/Tilt Movements</b>		Manual control for Pan/Tilt movements
	<b>Special</b>		
	<b>White Temperature</b>		Manual control for Color temperature
	<b>Dimmer</b>		Manual control for Dimmer
	<b>Shutter</b>		Manual control for Shutter
	<b>White</b>		Manual control for White
	<b>Blue</b>		Manual control for blue
	<b>Green</b>		Manual control for green
	<b>Red</b>		Manual control for red
	<b>Color Wheel</b>		Manual control for the color wheel
	<b>Tilt</b>		Manual control for Tilt (Y-movement)
<b>Adjust</b>	<b>Key code xxxx</b>		Use the code for entering the calibration menu (for authorized persons only)
	<b>Display Contrast</b>		Adjustment for the Display contrast
	<b>PWM - Frequ. Adj.</b>		Changes PMW frequency
	<b>Pan Offset</b>		Calibration for Pan-Offset
	<b>Tilt Offset</b>		Calibration for Tilt-Offset
	<b>LED adjust</b>		
		<b>White adjust red</b>	Adjust intensity for red channel
		<b>White adjust blue</b>	Adjust intensity for blue channel
		<b>White adjust green</b>	Adjust intensity for green channel
	<b>Clear EEPROM</b>		Erase EEPROM memory
	<b>Diagnose</b>		Diagnose fixture functions
<b>DMX Image</b>	<b>Set image if DMX off</b>		Activates a stored scene if DMX is off
	<b>Save image in memory</b>		Stores the scene currently sent to the unit
<b>DMX input Monitor</b>			Indicates the presently received DMX signal per DMX channel
	<b>Pan</b>		Instantaneous value for Pan
	<b>Tilt</b>		Instantaneous value for Tilt
	<b>Pattern Byte 3</b>		Instantaneous value for Pattern Byte 3
	<b>Pattern Byte 2</b>		Instantaneous value for Pattern Byte 2
	<b>Pattern Byte 1</b>		Instantaneous value for Pattern Byte 1

← DOWN - UP →

	<b>Pattern</b>	Instantaneous value for Pattern channel / bank
	<b>Zoom</b>	Instantaneous value for Zoom
	<b>Speed Movements</b>	Speed adjustment for Pan/Tilt movements → see item below
	<b>Pan/Tilt Movements</b>	Instantaneous value for Pan/Tilt movements
	<b>Special</b>	Instantaneous value for Special
	<b>White Temperature</b>	Adjustment of the color temperature for WHITE
	<b>Dimmer</b>	Instantaneous value for Dimmer
	<b>Shutter</b>	Instantaneous value for Shutter
	<b>White</b>	Instantaneous value for White
	<b>Blue</b>	Instantaneous value for Blue
	<b>Green</b>	Instantaneous value for Green
	<b>Red</b>	Instantaneous value for Red
	<b>Color Wheel</b>	Instantaneous value for Color Mixing unit
<b>Set DMX Mode</b>	<b>Compressed Mode</b>	Select the desired DMX Mode
	<b>Normal Mode</b>	Fixture works in "Compressed" mode → see also section 5 unterhalb
	<b>High-Res. Mode</b>	Fixture works in "Normal" mode → see also section 5 unterhalb
<b>Position feedback</b>		Fixture works in "High Resolution" mode → see also section 5 unterhalb
		Switch automatic position feedback ON/OFF
	<b>Reverse Pan</b>	Invert Pan movements: ON/OFF
	<b>Reverse Tilt</b>	Invert Tilt movements: ON/OFF
<b>Reset</b>		RESET and new calibration for all functions

## 5 DMX Channel Selection (DMX Protocol)

### 5.1 Normal-Mode (26 DMX channels)

Channel	Function	Time and Value	DMX	HEX	%
<b>1) PAN High</b>	Pan coarse	0° - 660°	0..255	00..FF	0..100
<b>2) PAN Low</b>	Pan fine		0..255	00..FF	0..100
<b>3) Tilt High</b>	Tilt coarse	0° - 260°	0..255	00..FF	0..100
<b>4) Tilt Low</b>	Tilt fine		0..255	00..FF	0..100
<b>5) Color (fixed)</b>	Colors adjustable via RGB		0..7	00..07	0..2..5
	Color 01 - Red <sup>1)</sup>		8..15	08..0F	3..5.5
	Color 02 - Amber <sup>1)</sup>		16..23	10..17	6..8.5
	Color 03 - Warm Yellow <sup>1)</sup>		24..31	18..1F	9..12.5
	Color 04 - Yellow <sup>1)</sup>		32..39	20..27	13..15.5
	Color 05 - Green <sup>1)</sup>		40..47	28..2F	16..18.5
	Color 06 - Turquoise <sup>1)</sup>		48..55	30..37	19..21.5
	Color 07 - Cyan <sup>1)</sup>		56..63	38..3F	22..24.5
	Color 08 - Blue <sup>1)</sup>		64..71	40..47	25..27.5
	Color 09 - Lavender <sup>1)</sup>		72..79	48..4F	28..30.5
	Color 10 - Malve <sup>1)</sup>		80..87	50..57	31..34.5
	Color 11 - Magenta <sup>1)</sup>		88..95	58..5F	35..37.5
	Color 12 - Pink <sup>1)</sup>		96..103	60..67	38..40.5
	White - CTO	3200K	104..111	68..6F	41..43.5
	White	5600K	112..119	70..77	44..46.5
	White - CTB	7200K	120..127	78..7F	47..49.5
Rainbow Effect Stop <sup>2)</sup>		128	80	50	
Rainbow Effect <sup>3)</sup>	slow - fast	129..223	81..DF	51..88	
Random colors	slow - fast	224..255	E0..FF	89..100	
<b>6) Red</b>	Color mixing system - Red	0 - 100%	0..255	00..FF	0..100
<b>7) Green</b>	Color mixing system - Green	0 - 100%	0..255	00..FF	0..100
<b>8) Blue</b>	Color mixing system - Blue	0 - 100%	0..255	00..FF	0..100
<b>9) White</b>	Color mixing system - White	0 - 100%	0..255	00..FF	0..100
<b>10) Shutter</b>	Shutter closed		0..15	00..0F	0..5.5
	Shutter pulse random	slow – fast	16..47	10..2F	6..18.5
	Fade on, snap off (random patterns)	slow – fast	48..79	30..4F	19..31
	Snap on, fade off (random patterns)	slow – fast	80..111	50..6F	32..43
	Fade on, fade off (random patterns)	slow – fast	112..143	70..8F	44..56
	Strobe random	5s - 0.1s	144..199	90..C7	57..77
	Strobe effect slow - fast	1 Hz - 10 Hz	200..239	C8..EF	78..94
	Shutter open		240..255	F0..FF	95..100
<b>11) Dimmer</b>	Intensity	0 - 100%	0..255	0..FF	0..100
<b>12) CTO</b>	No CTO		0..7	0..07	0..2.5
	Continuous color temperature correction	Applicable for ALL colors	8..255	08..FF	3..100
<b>13) Special</b>	Pattern Block 1 → See channel 17		0..3	00..03	0..1
	Pattern Block 2 → See channel 17		4..7	04..07	2..3
	Pattern Block 3 → See channel 17		8..11	08..0B	3..4
	Pattern Block 4 → See channel 17		12..15	0C..0F	5..6
	Pattern Block 5 → See channel 17		16..19	10..13	6..7
	Pattern Block 6 → See channel 17		20..23	14..17	8..9
	Pattern Block 7 → See channel 17		24..27	18..1B	9..10
	Pattern Block 8 → See channel 17		28..31	1C..1F	11..12
	Pattern Block 9 → See channel 17		32..35	20..23	12..13
	Pattern Block 10 → See channel 17		36..39	24..27	14..15

Channel	Function	Time and Value	DMX	HEX	%	
	<b>Enable Animation</b>		80..83	50..53	31..32	
	→ use channel 17 to select → use channel 18 so set step → use channel 19 to start / for speed					
	Set Dimmer to soft mode		84..87	54..57	33..34	
	Change PWM frequency		100..200	64..C8	40..78	
	Set Maximum Zoom to 247	> 1 sec	208..211	D0..D3	82..83	
	Set Maximum Zoom to 255	> 1 sec	212..215	D4..D7	84..85	
	Set Zoom to normal	> 1 sec	216..219	D8..DB	85..86	
	Set Zoom to inverted	> 1 sec	220..223	DC..DF	86..87	
	<b>RESET</b>	> 1 sec	250..255	FA..FF	98..100	
<b>14) Movement macros</b>	<b>No macros</b>		0	00	0	
	<b>Movement</b>	<b>Size</b>	<b>Phase</b>	Use "Speed" to adjust		
	PAN	1	0°	01..01	01..01	0.5
		1	90°	02..03	02..03	1.0
		1	180°	04..05	04..05	1.7
		1	270°	06..07	06..07	2.5
	PAN	2	0°	08..09	08..09	3.3
		2	90°	10..11	0A..0B	4.1
		2	180°	12..13	0C..0D	4.9
		2	270°	14..15	0E..0F	5.7
	PAN	3	0°	16..17	11..11	6.5
		3	90°	18..19	12..13	7.3
		3	180°	20..21	14..15	8.0
		3	270°	22..23	16..17	8.8
	PAN	4	0°	24..25	18..19	9.6
		4	90°	26..27	1A..1B	10.4
		4	180°	28..29	1C..1D	11.2
		4	270°	30..31	1E..1F	12
	TILT	size / phase see PAN		32..63	20..3F	13..25
	PAN / TILT	size / phase see PAN		64..95	40..5F	26..37
	PAN / TILT (inverse)	size / phase see PAN		96..127	60..7F	38..50
	Circle	size / phase see PAN		128..159	80..9F	51..62
	Circle (inverse)	size / phase see PAN		160..191	A0..BF	63..75
	Lying eight	size / phase see PAN		193..223	C0..DF	76..87
	Random movement	size / phase see PAN		224..255	E0..FF	88..100
<b>15) Pan / Tilt Speed</b>	Pan/Tilt movement speed from controller		0..1	00..01	0..0.5	
	Pan/Tilt, slow – fast Use this channel for the speed of the macros on channel 14.		02..255	02..FF	1..100	
<b>16) Zoom</b>	Wide (flood) - narrow (spot)	50° - 7°	0...255	00...FF	0...100	
<b>17) Pattern / Animation</b>	No pattern		0..2	00..02	0..1	
	Pre-defined patterns / animations <sup>4) 5)</sup>	See Special Channel 13	03..253	03..FD	2..99	
	Activates direct access to LED Lenses	See Channel 18 - 26	254..255	FE..FF	100	
<b>18) Pattern Section 1 <sup>4)</sup></b>	Direct activation of lenses 1 thru 8 <sup>4)</sup>	Activation in binary style	0...255	00...FF	0...100	
<b>19) Pattern Section 2 <sup>5)</sup></b>	Direct activation of lenses 9 thru 16 <sup>5)</sup>	Activation in binary style	0...255	00...FF	0...100	
<b>20) Pattern Section 3</b>	Direct activation of lenses 17 thru 19	Activation in binary style	0...255	00...FF	0...100	
<b>21) Pattern Section 4</b>	Direct activation of lenses 20 thru 27	Activation in binary style	0...255	00...FF	0...100	

Channel	Function	Time and Value	DMX	HEX	%
<b>22) Pattern Section 5</b>	Direct activation of lenses 28 thru 35	Activation in binary style	0...255	00...FF	0...100
<b>23) Pattern Section 6</b>	Direct activation of lenses 36 thru 38	Activation in binary style	0...255	00...FF	0...100
<b>24) Pattern Section 7</b>	Direct activation of lenses 39 thru 46	Activation in binary style	0...255	00...FF	0...100
<b>25) Pattern Section 8</b>	Direct activation of lenses 47 thru 54	Activation in binary style	0...255	00...FF	0...100
<b>26) Pattern Section 9</b>	Direct activation of lens 55	Activation in binary style	0...255	00...FF	0...100

## 5.2 Compress-Mode (16 DMX channels)

Channel	Function	Time and Value	DMX	HEX	%	
<b>1) PAN High</b>	Pan coarse	0° - 660°	0..255	00..FF	0..100	
<b>2) PAN Low</b>	Pan fine		0..255	00..FF	0..100	
<b>3) Tilt High</b>	Tilt coarse	0° - 260°	0..255	00..FF	0..100	
<b>4) Tilt Low</b>	Tilt fine		0..255	00..FF	0..100	
<b>5) Color (fixed)</b>	Colors adjustable via RGB		0..7	00..07	0..2.5	
	Color 01 - Red <sup>1)</sup>		8..15	08..0F	3..5.5	
	Color 02 - Amber <sup>1)</sup>		16..23	10..17	6..8.5	
	Color 03 - Warm Yellow <sup>1)</sup>		24..31	18..1F	9..12.5	
	Color 04 - Yellow <sup>1)</sup>		32..39	20..27	13..15.5	
	Color 05 - Green <sup>1)</sup>		40..47	28..2F	16..18.5	
	Color 06 - Turquoise <sup>1)</sup>		48..55	30..37	19..21.5	
	Color 07 - Cyan <sup>1)</sup>		56..63	38..3F	22..24.5	
	Color 08 - Blue <sup>1)</sup>		64..71	40..47	25..27.5	
	Color 09 - Lavender <sup>1)</sup>		72..79	48..4F	28..30.5	
	Color 10 - Mauve <sup>1)</sup>		80..87	50..57	31..34.5	
	Color 11 - Magenta <sup>1)</sup>		88..95	58..5F	35..37.5	
	Color 12 - Pink <sup>1)</sup>		96..103	60..67	38..40.5	
	White – CTO	Color temperature 3200K		104..111	68..6F	41..43.5
	White	Color temperature 5600K		112..119	70..77	44..46.5
White – CTB	Color temperature 7200K		120..127	78..7F	47..49.5	
Rainbow Effect Stop <sup>2)</sup>			128	80	50	
Rainbow Effect <sup>3)</sup>	slow - fast		129..223	81..DF	51..88	
Rainbow Effect, random colors	slow - fast		224..255	E0..FF	89..100	
<b>6) Red</b>	Color mixing system - Red	0 - 100%	0..255	00..FF	0..100	
<b>7) Green</b>	Color mixing system - Green	0 - 100%	0..255	00..FF	0..100	
<b>8) Blue</b>	Color mixing system - Blue	0 - 100%	0..255	00..FF	0..100	
<b>9) White</b>	Color mixing system - White	0 - 100%	0..255	00..FF	0..100	
<b>10) Shutter</b>	Shutter closed		0..15	00..0F	0..5.5	
	Shutter pulse random	slow – fast	16..47	10..2F	6..18.5	
	Fade on, snap off (random patterns)	slow – fast	48..79	30..4F	19..31	
	Snap on, fade off (random patterns)	slow – fast	80..111	50..6F	32..43	
	Fade on, fade off (random patterns)	slow – fast	112..143	70..8F	44..56	
	Strobe random	5s - 0.1s	144..199	90..C7	57..77	
	Strobe effect slow – fast	1 Hz - 10 Hz	200..239	C8..EF	78..94	
	Shutter open		240..255	F0..FF	95..100	
<b>11) Dimmer</b>	Intensity	0 - 100%	0..255	0..FF	0..100	
<b>12) Zoom</b>	Wide (flood) - narrow (spot)	50° - 7°	0...255	00...FF	0...100	
<b>13) Special</b>	Pattern Block 1 → See channel 14		0..3	00..03	0..1	
	Pattern Block 2 → See channel 14		4..7	04..07	2..3	
	Pattern Block 3 → See channel 14		8..11	08..0B	3..4	
	Pattern Block 4 → See channel 14		12..15	0C..0F	5..6	
	Pattern Block 5 → See channel 14		16..19	10..13	6..7	
	Pattern Block 6 → See channel 14		20..23	14..17	8..9	
	Pattern Block 7 → See channel 14		24..27	18..1B	9..10	
	Pattern Block 8 → See channel 14		28..31	1C..1F	11..12	
	Pattern Block 9 → See channel 14		32..35	20..23	12..13	
	Pattern Block 10 → See channel 14		36..39	24..27	14..15	



Channel	Function	Time and Value	DMX	HEX	%
	<b>Enable Animation</b>		80..83	50..53	31..32
	→ use channel 14 to select → use channel 15 so set step → use channel 16 to start / for speed				
	Set Dimmer to soft mode		84..87	54..57	33..34
	Change PWM frequency		100..200	64..C8	40..78
	Set Maximum Zoom to 247	> 1 sec	208..211	D0..D3	82..83
	Set Maximum Zoom to 255	> 1 sec	212..215	D4..D7	84..85
	Set Zoom to normal	> 1 sec	216..219	D8..DB	85..86
	Set Zoom to inverted	> 1 sec	220..223	DC..DF	86..87
	<b>RESET</b>	> 1 sec	250..255	FA..FF	98..100
<b>14) Pattern / Animation</b>	No pattern		0..2	00..02	0..1
	Pre-defined patterns / animations <sup>4) 5)</sup>	See Special Channel 13	03..253	03..FD	2..99
<b>15) A-Step <sup>4)</sup></b>	Animation step <sup>4)</sup>	See Special Channel 13	00..255	00..FF	0..100
<b>16) A-Speed <sup>5)</sup></b>	Animation start / speed <sup>5)</sup>	See Special Channel 13	00..255	00..FF	0..100

### 5.3 High Resolution/Extended-Mode (27 DMX Channels)

Channel	Function	Time and Value	DMX	HEX	%	
<b>1) PAN High</b>	Pan coarse	0° - 660°	0..255	00..FF	0..100	
<b>2) PAN Low</b>	Pan fine		0..255	00..FF	0..100	
<b>3) Tilt High</b>	Tilt coarse	0° - 260°	0..255	00..FF	0..100	
<b>4) Tilt Low</b>	Tilt fine		0..255	00..FF	0..100	
<b>5) Red High</b>	Color mixing system – Red	0 - 100%	0..255	00..FF	0..100	
<b>6) Red Low</b>	Color mixing system – Red-Low		0..255	00..FF	0..100	
<b>7) Green High</b>	Color mixing system – Green	0 - 100%	0..255	00..FF	0..100	
<b>8) Green Low</b>	Color mixing system – Green-Low		0..255	00..FF	0..100	
<b>9) Blue High</b>	Color mixing system – Blue	0 - 100%	0..255	00..FF	0..100	
<b>10) Blue Low</b>	Color mixing system – Blue-Low		0..255	00..FF	0..100	
<b>11) White High</b>	Color mixing system – White	0 - 100%	0..255	00..FF	0..100	
<b>12) White Low</b>	Color mixing system – White-Low		0..255	00..FF	0..100	
<b>13) Shutter</b>	Shutter closed		0..15	00..0F	0..5.5	
	Shutter pulse random	slow – fast	16..47	10..2F	6..18.5	
	Fade on, snap off (random patterns)	slow – fast	48..79	30..4F	19..31	
	Snap on, fade off (random patterns)	slow – fast	80..111	50..6F	32..43	
	Fade on, fade off (random patterns)	slow – fast	112..143	70..8F	44..56	
	Strobe random	5s - 0.1s	144..199	90..C7	57..77	
	Strobe effect slow – fast	1 Hz - 10 Hz	200..239	C8..EF	78..94	
	Shutter open		240..255	F0..FF	95..100	
<b>14) Dimmer-High</b>	Intensity coarse	0 - 100%	0..255	0..FF	0..100	
<b>15) Dimmer-Low</b>	Intensity fine		0..255	0..FF	0..100	
<b>16) Zoom</b>	Wide (flood) - narrow (spot)	50° - 7°	0...255	00...FF	0...100	
<b>17) Special</b>	Pattern Block 1 → See channel 18		0..3	00..03	0..1	
	Pattern Block 2 → See channel 18		4..7	04..07	2..3	
	Pattern Block 3 → See channel 18		8..11	08..0B	3..4	
	Pattern Block 4 → See channel 18		12..15	0C..0F	5..6	
	Pattern Block 5 → See channel 18		16..19	10..13	6..7	
	Pattern Block 6 → See channel 18		20..23	14..17	8..9	
	Pattern Block 7 → See channel 18		24..27	18..1B	9..10	
	Pattern Block 8 → See channel 18		28..31	1C..1F	11..12	
	Pattern Block 9 → See channel 18		32..35	20..23	12..13	
	Pattern Block 10 → See channel 18		36..39	24..27	14..15	
	<b>Enable Animation</b>			<b>80..83</b>	<b>50..53</b>	<b>31..32</b>
		→ use channel 18 to select → use channel 19 so set step → use channel 20 to start/for speed				
		Set Dimmer to soft mode		84..87	54..57	33..34
		Change PWM frequency		100..200	64..C8	40..78
		Set Maximum Zoom to 247	> 1 sec	208..211	D0..D3	82..83
		Set Maximum Zoom to 255	> 1 sec	212..215	D4..D7	84..85
		Set Zoom to normal	> 1 sec	216..219	D8..DB	85..86
	Set Zoom to inverted	> 1 sec	220..223	DC..DF	86..87	
	<b>RESET</b>	> 1 sec	250..255	FA..FF	98..100	
<b>18) Pattern</b>	No pattern		0..2	00..02	0..1	
	Pre-defined patterns / animations <sup>4) 5)</sup>	See Special Channel 17	03..253	03..FD	2..99	
	Activates direct access to LED Lenses		254..255	FE..FF	100	
<b>19) Pattern Section 1 <sup>4)</sup></b>	Direct activation of lenses 1 thru 8 <sup>4)</sup>	Activation in binary style	0...255	00...FF	0...100	

Channel	Function	Time and Value	DMX	HEX	%
<b>20) Pattern Section 2</b> <sup>5)</sup>	Direct activation of lenses 9 thru 16 <sup>5)</sup>	Activation in binary style	0...255	00...FF	0...100
<b>21) Pattern Section 3</b>	Direct activation of lenses 17 thru 19	Activation in binary style	0...255	00...FF	0...100
<b>22) Pattern Section 4</b>	Direct activation of lenses 20 thru 27	Activation in binary style	0...255	00...FF	0...100
<b>23) Pattern Section 5</b>	Direct activation of lenses 28 thru 35	Activation in binary style	0...255	00...FF	0...100
<b>24) Pattern Section 6</b>	Direct activation of lenses 36 thru 38	Activation in binary style	0...255	00...FF	0...100
<b>25) Pattern Section 7</b>	Direct activation of lenses 39 thru 46	Activation in binary style	0...255	00...FF	0...100
<b>26) Pattern Section 8</b>	Direct activation of lenses 47 thru 54	Activation in binary style	0...255	00...FF	0...100
<b>27) Pattern Section 9</b>	Direct activation of lens 55	Activation in binary style	0...255	00...FF	0...100

<sup>1)</sup> The predefined colors can be used as start-colors for the Rainbow effect. Please select first a desired start-color before you activate the rainbow effect. All **IMPRESSION X4XL** will then start from that color and will execute the rainbow effect synchronously. Different **IMPRESSION X4XL** can have different start-colors but will still execute the rainbow effect synchronously. If you choose a color different from the ones marked with <sup>1)</sup> in the tables above the rainbow start-color will be red.

<sup>2)</sup> Rainbow-effect Stop will pause this function. After resuming the rainbow-effect will be continued from the current color.

<sup>3)</sup> The Rainbow-effect will run synchronously only if started from one of the predefined colors (see also <sup>1)</sup> before).

<sup>4)</sup> If the Animation mode is activated through Special Channel set to DMX = 80..83 then the Function of this Channel is:

Animation step		00..255	00..FF	0..100
----------------	--	---------	--------	--------

*Use this Channel to select the starting point of the animation.*

<sup>5)</sup> If the Animation mode is activated through Special Channel set to DMX = 80..83 then the Function of this Channel is:

Animation start / speed		00..255	00..FF	0..100
-------------------------	--	---------	--------	--------

*Use this Channel to start the animation by setting the speed to run it.*

**Locking and unlocking the Control Panel**

Please lock and unlock the control panel by pressing the menu keys **MODE & ENTER & UP** at the same time.

**Additional Display Indications**

As a default you'll find the following additional information in the first row of the LCD display:

Vxx/xx/xx/xx/x

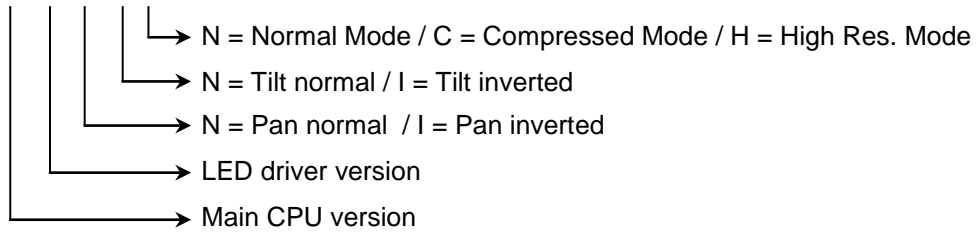

## 6 Maintaining and Cleaning

The **IMPRESSION X4XL** is a fixture of very low maintenance. It is only necessary to clean the air inlets and outlets as well as the optical LED lenses from time to time. For safe operation it is absolutely essential that the fixture is kept clean and that dust, dirt and smoke-fluid residues must not build up on, or within the fixture. Otherwise the fixture's light-output will be significantly reduced or damages can occur. Regular cleaning will not only ensure the maximum light-output, but will also allow the fixture to operate reliably throughout its life.

**A soft lint-free cloth moistened with any good glass cleaning fluid is recommended to clean the lenses.**



**Attention:**

**Under no circumstances should alcohol or solvents be used to clean the lenses!**

### 6.1 Safety regulations

- **Pull out the mains power plug!**
- Wait min. 15 minutes after disconnecting power to allow the fixture to cool down.

### 6.2 Maintenance and Interval (rule-of-thumb)

The contamination of the fixture depends on the environment details. Hence no general guidelines can be given. The intervals given below are only suggestions from our experience.

Position	Interval	In this way
LED reflector and optical system	weekly	soft brush /lint-free cloth
Fan and air channel	monthly	vacuum cleaner, airbrush, etc.

**Attention:**

- **Never let optical parts come into contact with oil, fat, alcohol or similar solvents.**
- **Before running the fixture wait until all parts are dry.**
- **Never touch lenses with bare fingers.**

## 7 Technical Specifications

<b>Power supply</b>	
<b>Power consumption</b>	1200 VA (Watt)
<b>Power Input</b>	~100-240 V AC, 50-60 Hz (wide range input)
<b>Fuse protection</b>	Micro-fuse 5x20 mm, T12A
<b>Operational Parameters</b>	
<b>Max. Ambient Temperature</b>	5° - 45°C (integrated overheating switch)
<b>Mounting Position</b>	Any (see relevant chapter)
<b>Lighting System - Additive Color mixing</b>	
<b>LED Type</b>	55 x Osram Ostar RGBW multi-chip
<b>Lifetime</b>	50,000 h
Wavelength optimized for maximum presentable color space	
<b>Optical System</b>	
Full RGBW / High efficient Collimator cluster	
<b>Shutter / Dimmer (8/16 Bit)</b>	
Strobe- Effect with variable speed between 1 - 10 flashes per second, Random-Strobe, Pulse-Effects	
Continuous Dimmer 0 - 100%	
<b>Zoom</b>	
7 to 50 degree continuous zoom	
<b>Optical Patterns</b>	
Several hundred pre-defined beam patterns with direct access and manipulation	
<b>DMX Control</b>	
Standard USITT DMX-512, 3/5 pin XLR: [+]=Pin 3 / [-]=Pin 2 / [Ground]=Pin 1 / Pin 4&5 N.C. The DMX- Addressing starts at the DMX channel [001].	
<b>Pan / Tilt (8/16 Bit)</b>	
<b>Pan- movement</b>	<b>660° in min. 3,2 seconds (Position Feedback)</b>
<b>Tilt- movement</b>	<b>260° in min. 1,5 seconds (Position Feedback)</b>
<b>Weights and Measures</b>	
<b>Width of the base</b>	<b>521 mm</b>
<b>Length of the base</b>	<b>361 mm</b>
<b>height (head vertical)</b>	<b>519 mm (incl. standing foot/tripod)</b>
<b>Weight (net)</b>	<b>31.0 kg</b>

## 8 Dimensions

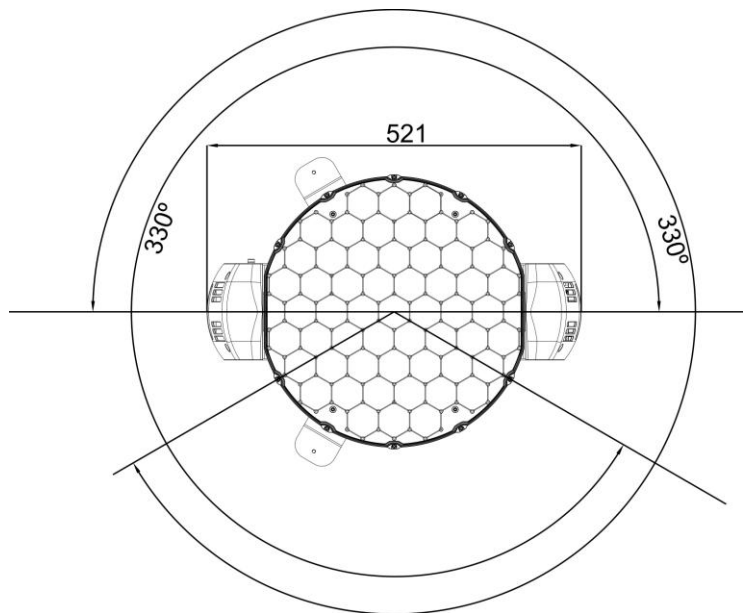
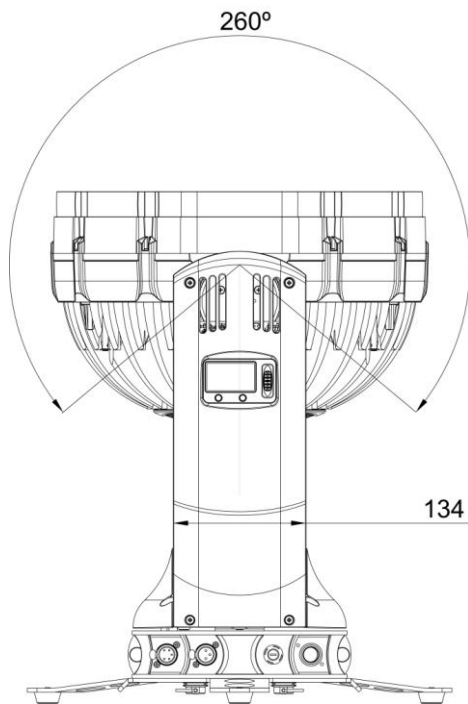
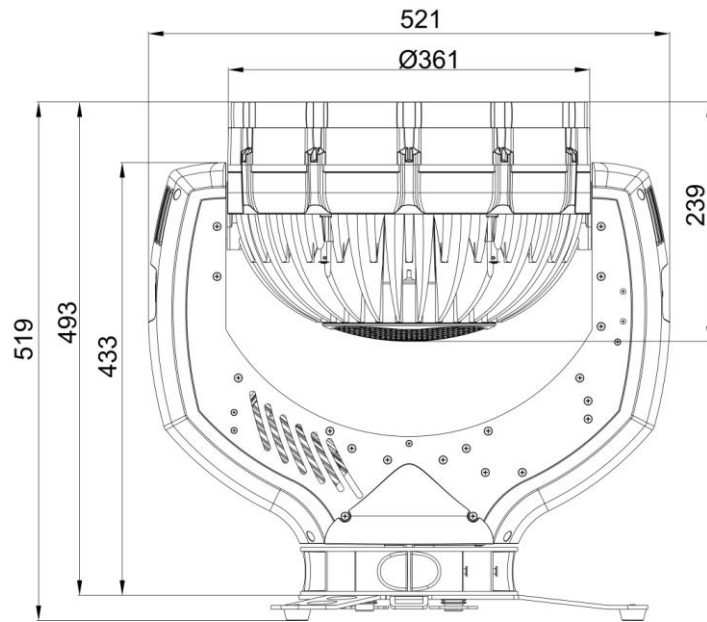

PAN movement range: 660°

## 9 Index

<b>B</b>	
<b>beam-lights</b> .....	6
BGV C1.....	7
<b>C</b>	
Camlock.....	8
Cleaning.....	22
Compress-Mode .....	17
<b>D</b>	
<b>Danger of BURNING</b> .....	5
Description of Device.....	4
Dimensions .....	24
DIN VDE 0711-217 .....	7
<b>Display Indications</b> .....	21
<b>DMX</b> .....	11
<b>E</b>	
EN 60598-2-17 .....	11
<b>Enter-key</b> .....	11
Eyelets .....	8
<b>H</b>	
Half-couplers (clamps).....	10
High Resolution (Extended) -Mode .....	19
<b>L</b>	
<b>LED Class 2M</b> .....	5
<b>M</b>	
Maintenance .....	22
Menu Field .....	11
Micro-fuse .....	11
<b>Mode-key</b> .....	11
<b>Mounting</b> .....	7
Mounting in hanging Position .....	9
Mounting in sidewise Position.....	10
Mounting on the Floor .....	8
<b>N</b>	
Normal-Mode .....	14
<b>O</b>	
<b>Optical parts</b> .....	22
<b>P</b>	
Pan- Movement.....	23
plano-convex lenses .....	6
<b>Power Supply</b> .....	11
<b>R</b>	
<b>RESET</b> .....	15, 18, 19
<b>S</b>	
Safety distance .....	7
Safety information .....	6
Safety Instructions .....	5
<b>Secure the Device</b> .....	11
sunlight.....	6
<b>T</b>	
<b>Technical Specifications</b> .....	23
Tilt- Movement .....	23
<b>U</b>	
<b>Up/Down-keys</b> .....	11
<b>V</b>	
VBG 70 .....	7
<b>W</b>	
Warranty claims .....	5
Weights and Measures .....	23



