



# Hoist / Motor Controller

## Instruction Manual

### Models:

**MC4-DV-CASE**

**MC4-DV-CASE-LINK**

**version 1 since 3/2014**

### **ATTENTION!**

This instruction manual contains important information about the installation and the use of the equipment. Please read and follow these instructions carefully.

Always ensure that the power to the equipment is disconnected before opening the equipment or commencing any maintenance work.

# 1. General information

## ***IMPORTANT INSTRUCTIONS!***

All safety and operating instructions should be read before the equipment is installed or operated.

## ***IMPORTANT SAFETY INFORMATION***

The following general safety precautions have to be observed during all phases of operation, service, and the repair of this equipment. Failure to comply with these precautions or with specific warnings in this manual violates safety standards of design, manufacture, and the intended use of this equipment.

### ***Do not operate in an explosive atmosphere!***

Do not operate this equipment in the presence of flammable gases or fumes. Operation of any electrical instrument in such an environment constitutes a definite safety hazard.

### ***Water, moisture, heat and humidity***

Do not operate this equipment near water, in areas with wet floors or in high humidity atmosphere where condensation forms on the equipment. It should never be placed near or over a heat register or other source of heated air and it should not be installed or operated without proper ventilation.

## 2. Functions and Control

Motor Controller is designed to control up to 4 electrically compatible motors separately or simultaneously; controlled via cable remote controller MC4-DV-CASE REMOTE.

Each device is equipped with MPA /Manual Phase Align/ module that allows changing the phases easily by rotating pins L2 and L3 on the main connector.

All electrical components carry their own individual CE and comply with European Directives. The components are housed in a robust steel 19" rack casing with powder coating. Unit complies with the CE according to the Certification of Conformity that is attached to this manual.

### 3. MC4-DV-CASE

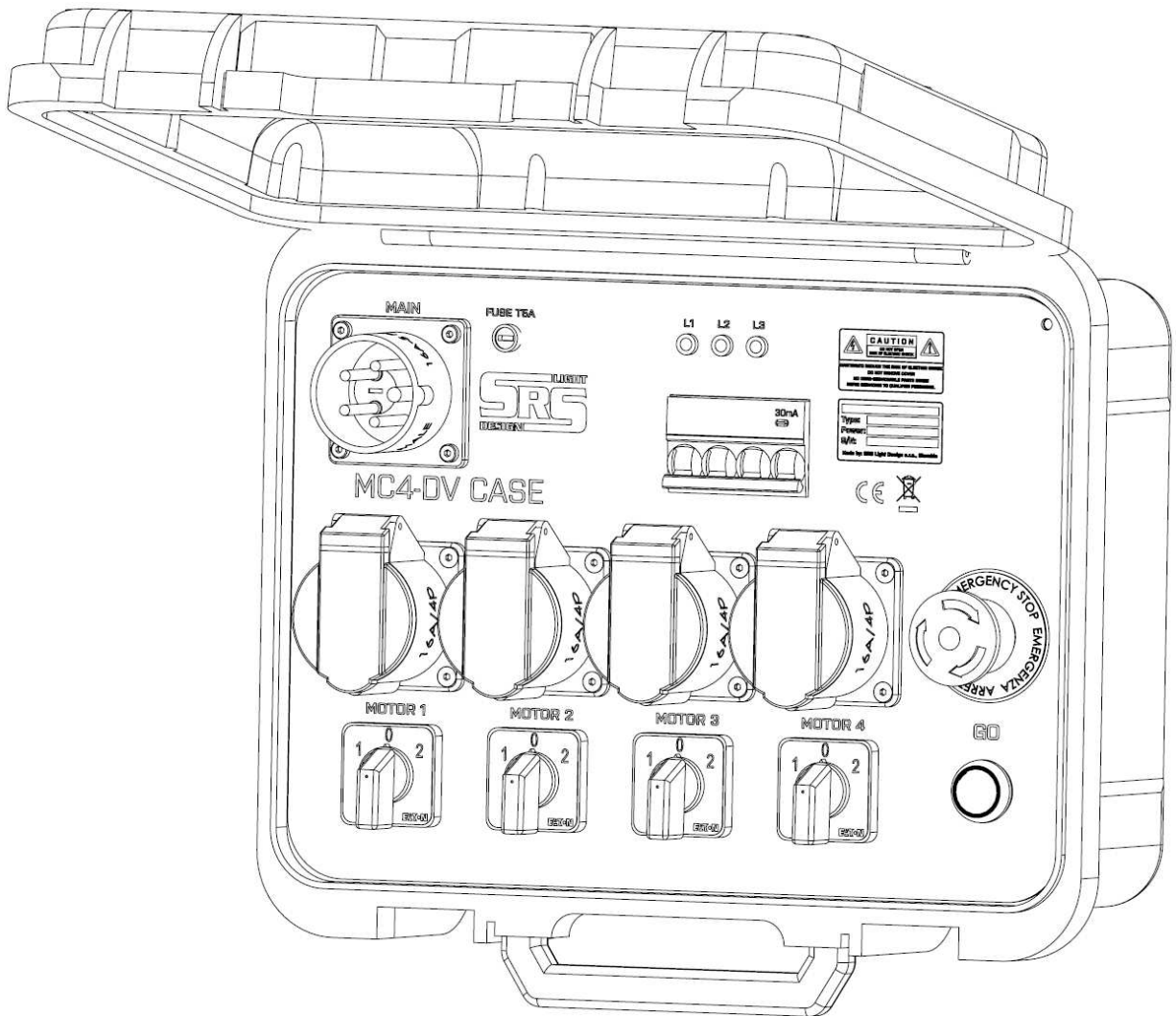

#### **EMERGENCY STOP:**

Emergency is a RED button located in the middle of yellow circle.

Emergency stop button turns the MC4-DV CASE controller to an inactive state and stays in it.

To release it, rotate the emergency stop clockwise.

#### **GO:**

When active, the green pushbutton turns the selected channels of Hoist Control system ON. Once the GO button is released, the energizing of the hoists is turned off.

## 4. MC4-DV-CASE LINK

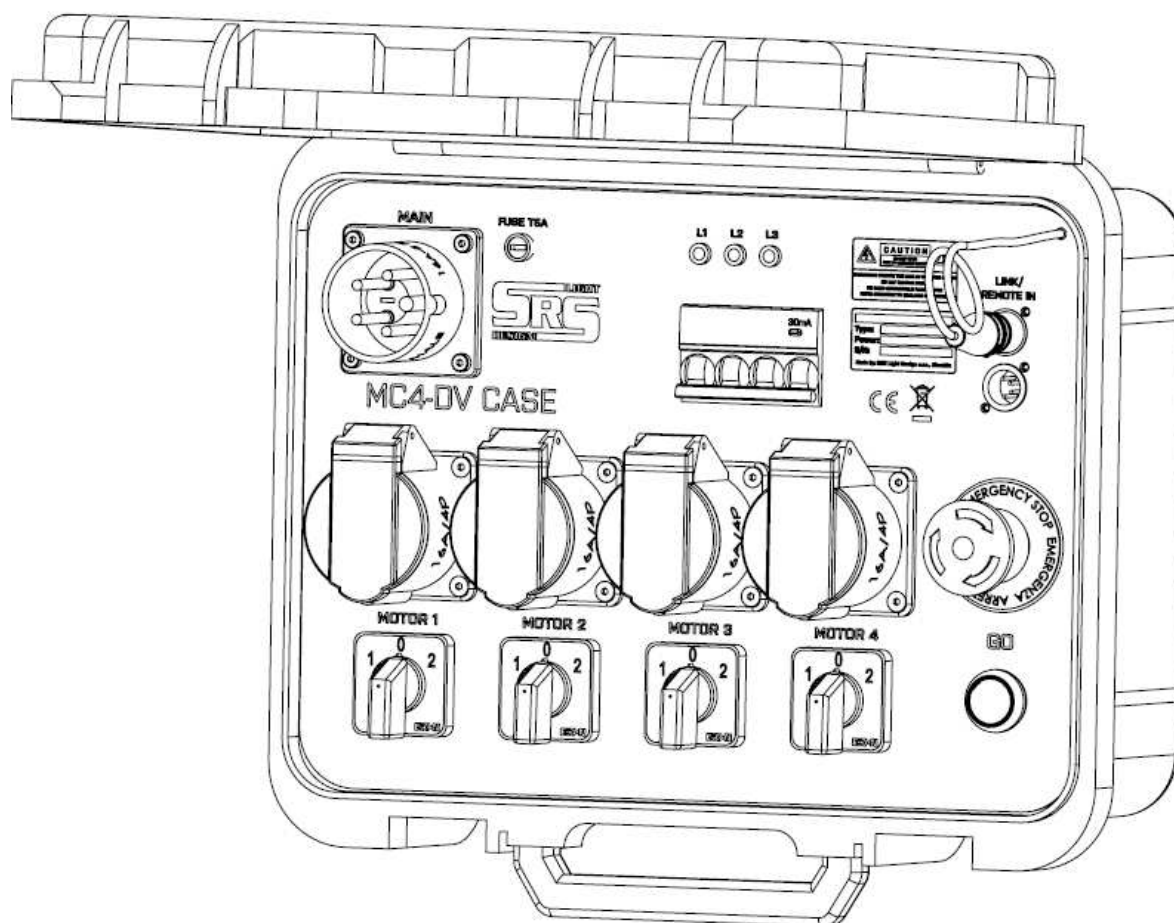

### **EMERGENCY STOP:**

Emergency is a RED button located in the middle of yellow circle.

Emergency stop button turns the MC4-DV CASE controller to an inactive state and stays in it.

To release it, rotate the emergency stop clockwise.

**When several more controllers are linked together, the press of any E-STOP button will shut down all connected controllers.**

### **GO:**

When active, the green pushbutton turns the selected channels of Hoist Control system ON. Once the GO button is released, the energizing of the hoists is turned off.

### **LINK:**

For link of several controllers use 4pin MC-x-LINK cable. Safety breach needs to be connected in last controller of chain. See schematics for more details.

## 5. Operation

The Motors/Hoists connected to the MC4-DV-CASE controller can be activated individually or simultaneously using the GO button located on the front panel, via cable remote or by linked controller. The selection of the hoists that are controlled is made by switches located on front panel.

Several MC4-DV-CASE controllers can be linked together to create bigger systems.

### 5.1 How to start

- Connect the CEE32A/5p plug to the AC400V power supply and check GFI and control MCB.
- If the main is OK, LED OK is green and either 123 or 132 align LED is ON.
- If there is 123 align, all outputs will work normally.
- If there is 132 align, the outputs will work reversely. In order to switch the align of phases to 123, rotate pins L2 and L3 on the main connector.
- If there is a problem with main voltages, red ERR/FAIL LED is ON. This is due to one missing phase. Disconnect mains and check line voltage and the presence of all phases.
- Connect the plugs of the electric hoists to the sockets of the CEE16A/4p or CEE16A/5p /\*on request/
- Check if all emergency STOP buttons /on device and all other linked devices in system/ are released and there is presence of security plug/breach with short circuit in between pins 3 and 4 on last unit in system.

### 5.2 To Move a Single/Several Motor(s):

- Set the UP/DOWN switch for each motor to the desired direction.
- Hold the GO button until all motors are moved the desired height and release.

### 5.3 Controller normal operation:

In this mode, the controller is operated by GO and E-STOP buttons located on the front panel.

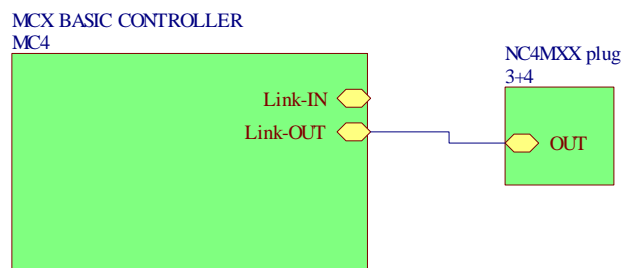

**During operation, the NC4MXX plug must be connected to the last controller in chain**

## 5.4 Controller with remote operation:

In this mode, the controller is operated by GO and E-STOP buttons located either on the front panel or on the MC4-DV-CASE REMOTE.

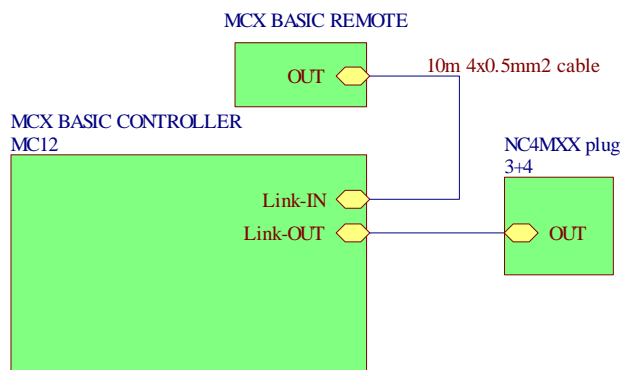

**During operation, the NC4MXX plug must be connected to the last controller in chain**

## 5.5 Controller link operation:

In this mode, all linked controllers are operated by any GO and E-STOP button located either on the front panel or on the MC4-DV-CASE REMOTE.

**Don't forget to plug the NC4MXX plug to the last controller in chain.**

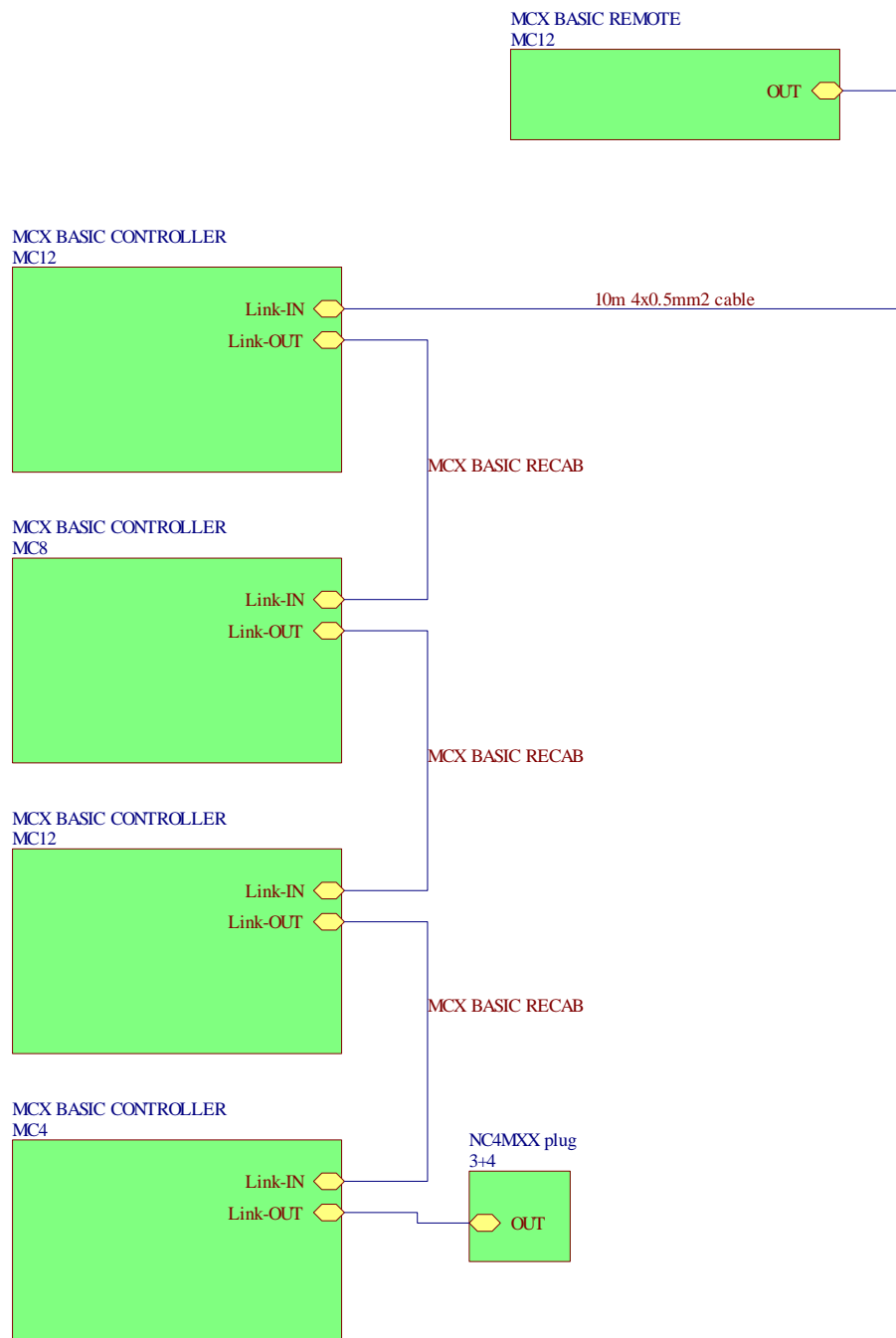

During operation, the NC4MXX plug must be connected to the last controller in chain



## 5.6 MC4-DV CASE REMOTE

Remote controller allows controlling of GO and E-STOP buttons for single controller or all linked controllers. Standard length of cable is 10m. The length can be altered according to customer's needs. There is also a 1m MC4-DV-CASE RECAP cable for linking of controllers.



### **STOP:**

This switch protects the base unit from undesired operation and turns the MC4-DV-CASE controller to inactive state. Stop button is of red color. Once the STOP button has been pressed, it is locked in an inactive position and must be rotated clockwise to be released.

### **GO:**

When active, the pushbutton turns the selected channels of Hoist Control system ON. Once the GO button is released, the energizing of the hoists is turned off.

## 6. Description of connectors

### 6.1 LINK in/out connector

Lines 3 and 4 are normally closed – NC, by default for normal operation. Due to this, it is necessary to fit the safety breach /MXX connector/ to the link OUT connector with the short circuit between pins 3 and 4 for normal operation.

**This breach must be connected to the last controller in system if the controllers are linked.**

#### **Neutrik NC4FXX**

- Pin 1. Remote go in
- Pin 2. Remote go out
- Pin 3. Safety in
- Pin 4. Safety out

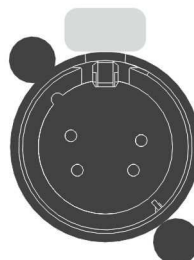

## 6.2 CEE16/4p motor/hoist connector

To change the direction of movement, the rotation from 123 to 132 is required. In an inactive state, this connector is without power.

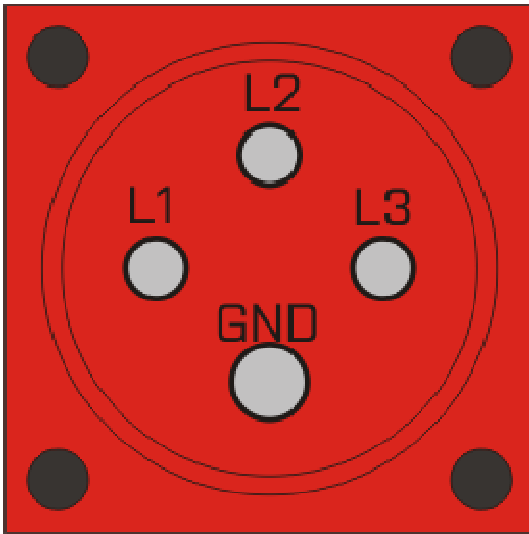

On request, unit can be equipped with CEE16/5p connector. In this case the NEUTRAL on output connector is not connected.

## 6.3 Protection and Safety:

- GFI/RCD 30mA outputs protected by hoist controller
- MCB C16A overcurrent protection
- MPA – Manual Phase Align
- Mains contactor

## 6.4 Dimensions /W x D x H/ & Weight

AED 4DV-CASE: Plastic case: 340 x 425 x 170 mm, weight: 7.7kg

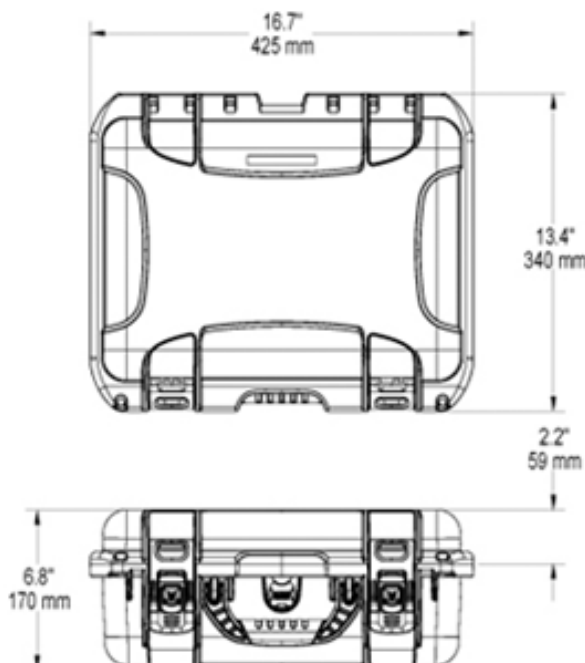

## 7. Warranty

MC4-DV-CASE hoist controller is covered by a 2-year manufacturer's warranty. For extended warranty conditions, please contact the manufacturer at [sales@srslight.com](mailto:sales@srslight.com).

The guarantee covers the original factory installed components of the controller and their correct functioning.

The warranty voids if any part or replacement component is installed or modified without authorization from the manufacturer and/or the internal circuit is tampered or modified and/or the controller is operated outside of normal using conditions – electrical power supply is not conform or there is connection error or mechanical damage of controller, including overload and improper use.

The manufacturer always helps with the repair of each unit.

## 8. Declaration of conformity

### DECLARATION OF CONFORMITY

According to guidelines 89/336 EEC and 92/31 EEC, 90/337 CEE Annex II A:

**Name of producer:** SRS Light Design s.r.o.

**Address of producer:** Rybnicna 36/D, SK- 83106 Bratislava, Slovak Republic  
[www.srslight.com/](http://www.srslight.com/) [sales@srslight.com](mailto:sales@srslight.com), +421244681417

*Declares that the product*

**Name of product:** **MC4-DV-CASE** hoist controller + variants

#### **Types:**

MC4-DV-CASE, MC4-DV-CASE-LINK : CEE output motor controller

*Corresponds with following harmonized standards:*

**Safety:** EN 60065  
EN 60950  
EN 60204-1  
EN 13850  
EN 12100-2  
IEC 60364

**EMC:** EN55103-1, resp. EN55103-2

**And**

*Is in compliance with following requirements:*

**Machinery directive:** 98/37 EC

**Low Voltage directive:** EEC 73/23

Bratislava, March 4, 2014

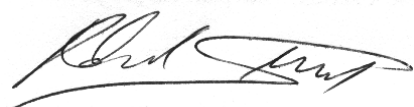

Robert Sloboda