

# SHURE®

LEGENDARY  
PERFORMANCE™



## AXT620 Ethernet Switch



## IMPORTANT SAFETY INSTRUCTIONS

1. READ these instructions.
2. KEEP these instructions.
3. HEED all warnings.
4. FOLLOW all instructions.
5. DO NOT use this apparatus near water.
6. CLEAN ONLY with dry cloth.
7. DO NOT block any ventilation openings. Install in accordance with the manufacturer's instructions.
8. DO NOT install near any heat sources such as radiators, heat registers, stoves, or other apparatus (including amplifiers) that produce heat.
9. DO NOT defeat the safety purpose of the polarized or grounding type plug. A polarized plug has two blades with one wider than the other. A grounding type plug has two blades and a third grounding prong. The wider blade or the third prong are provided for your safety. If the provided plug does not fit into your outlet, consult an electrician for replacement of the obsolete outlet.
10. PROTECT the power cord from being walked on or pinched, particularly at plugs, convenience receptacles, and the point where they exit from the apparatus.
11. ONLY USE attachments/accessories specified by the manufacturer.
12. USE only with a cart, stand, tripod, bracket, or table specified by the manufacturer, or sold with the apparatus. When a cart is used, use caution when moving the cart/apparatus combination to avoid injury from tip-over.
13. UNPLUG this apparatus during lightning storms or when unused for long periods of time.
14. REFER all servicing to qualified service personnel. Servicing is required when the apparatus has been damaged in any way, such as power supply cord or plug is damaged, liquid has been spilled or objects have fallen into the apparatus, the apparatus has been exposed to rain or moisture, does not operate normally, or has been dropped.
15. DO NOT expose the apparatus to dripping and splashing. DO NOT put objects filled with liquids, such as vases, on the apparatus.
16. The MAINS plug or an appliance coupler shall remain readily operable.
17. The airborne noise of the Apparatus does not exceed 70dB (A).
18. Apparatus with CLASS I construction shall be connected to a MAINS socket outlet with a protective earthing connection.
19. To reduce the risk of fire or electric shock, do not expose this apparatus to rain or moisture.
20. Do not attempt to modify this product. Doing so could result in personal injury and/or product failure.



This symbol indicates that dangerous voltage constituting a risk of electric shock is present within this unit.



This symbol indicates that there are important operating and maintenance instructions in the literature accompanying this unit.

**WARNING:** This product contains a chemical known to the State of California to cause cancer and birth defects or other reproductive harm.

**WARNING:** Voltages in this equipment are hazardous to life. No user-serviceable parts inside. Refer all servicing to qualified service personnel. The safety certifications do not apply when the operating voltage is changed from the factory setting.

**WARNING:** This product contains a chemical known to the State of California to cause cancer and birth defects or other reproductive harm.

# AXT620 Ethernet Switch

The AXT620 Ethernet Switch is a rugged, rack-mountable 9-port switch that simplifies the networking of Shure systems and minimizes network configuration setup. It is equipped with Power over Ethernet (PoE) ports for enabled devices and a DHCP server to automatically assign IP addresses to components.

## Features

- Rugged 1RU construction
- Internal power supply
- 8 rear panel ports
- Front panel port
- 4 Power over Ethernet (PoE) ports
- On-board DHCP server
- Easy system integration

## Included Components

- (1) PoE Managed Switch
- (4) Rubber footpads
- (1) Ethernet cable (10 ft.)
- (1) Rack-mount kit
- (1) Power Cord

## Front and Rear Panel

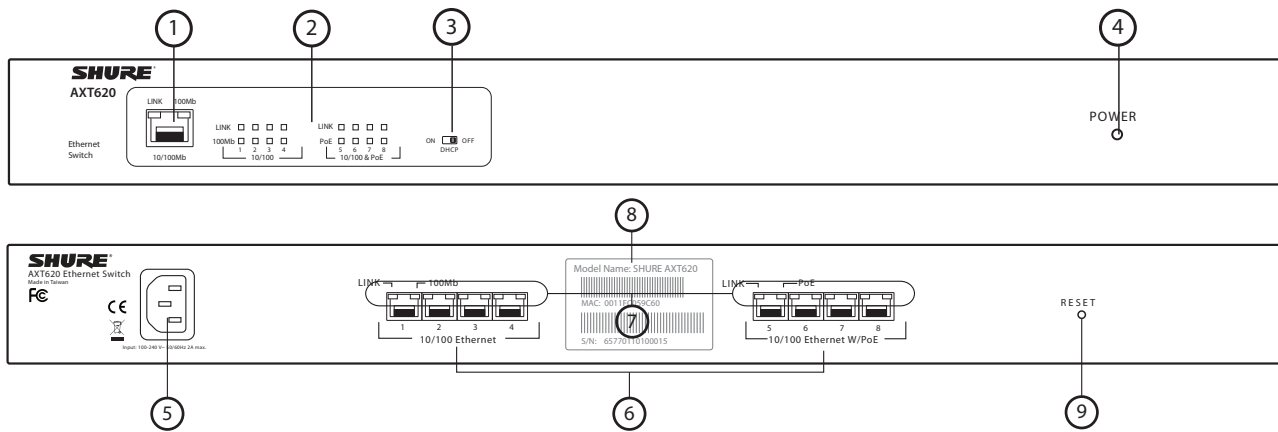

### ① RJ-45 Ports

One 10/100 N-way auto-sensing for 10Base-T or 100Base-TX connections.

### ② Front Panel LED Indicators

#### Link

- Green: Connected to network
- Blinking: Networking is active
- Off: Not connected to network

#### 100Mb

- Amber: The port is operating at speed of 100 Mb
- Off: The port is disconnected or not operating at speed of 100 Mb

#### PoE

- Amber: The port is supplying power to the connected PoE device
- Off: No powered device attached

### ③ DHCP Switch

Turns the DHCP server ON or OFF (Left side = On, Right side = Off)

### ④ Power

- Green: Power on
- Off: No AC power applied

### ⑤ Power cord socket

The switch will work with AC in the voltage range of AC 100-240V with frequency of 50-60Hz.

### ⑥ RJ-45 Ports

Eight 10/100 N-way auto-sensing for 10Base-T or 100Base-TX connections. Ports 5-8 also can supply power over Ethernet to enabled-devices.

### ⑦ Rear Panel LED Indicators

#### Link (port 1 ~ 8)

- Green: Connected to network
- Blinking: Networking is active
- Off: Not connected to network

#### 100Mb (port 1 ~ 4)

- Amber: The port is operating at speed of 100 Mb
- Off: The port is disconnected or not operating at speed of 100 Mb

#### PoE (port 5 ~ 8)

- Amber: The port is supplying power to the connected PoE device
- Off: No powered device attached

### ⑧ System information sticker

Displays the MAC address.

### ⑨ Reset button

Reboots the system. If you press the **Reset** button for over five seconds, the system will reset to factory defaults.

## Power On

Connect the power cord to the power socket on the rear panel of the switch.

## Rack-mount Installation

For proper ventilation, allow about at least four inches (10 cm) of clearance on the front and 3.4 inches (8 cm) on the back of the switch. This is especially important for enclosed rack installation.

---

## Web-Based Management

The switch is managed from an embedded web server, which offers advanced management features and lets you manage the switch from anywhere on the network through a standard web browser. The Web-Based Management supports Internet Explorer 6.0 or later version.

### Default Values

Change your user name and password for increased security.

IP Address: **192.168.1.1**

Subnet Mask: **255.255.255.0**

User Name: **root**

Password: **root**

---

## System Login

To configure the switch, you must log into the system via the internet.

1. Open a web browser. In the address bar, enter the IP address of the switch, and then press **Enter**.
2. On the login window, enter your credentials. For the initial login, use the default user name and password. Select **OK**. The Main page is displayed.

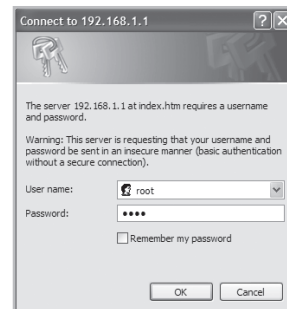
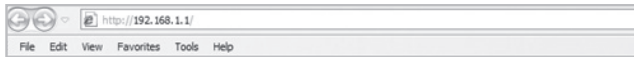

---

## Main Page

From the Main Page, you can navigate to the desired area of interest to configure and manage the switch options.



## System Information

This option lets you assign the system name, description, physical location, and contact personnel. You can also look up your firmware and kernel version here, as well as the MAC address.

## DHCP Server - Client Entries

When the DHCP server function is enabled, you can view DHCP client information here.

## DHCP Server - System Configuration

When you are using multiple switches to manage numerous devices, you can designate one switch to act as the DHCP server. All other switches must be designated as clients with the DHCP server set to OFF.

Only the server can have the DHCP switch set to ON.

## User Authentication

In this option, you can change the user name and password of the switch.

## TFTP Transaction

In this option, you can update the firmware of the switch. You will need to run a TFTP server on the computer connected to the switch, and then enter the IP address of the computer in the TFTP Server IP Address field. Then enter the name of the firmware file into the 'Firmware File Name' field and click Apply to start the upgrade process. Once the upgrade process is complete, you should click Factory Default on the left-hand side of the Main Page of the switch.

**NOTE:** Before doing a firmware upgrade, either unplug or power off all devices connected to the AXT620 except the computer.

## IP Configuration

The switch is a network device and needs to be assigned an IP address for identification on the network.

When making changes to the menu configuration settings, you must click **Apply** to make the changes to the switch.

## Power over Ethernet

In this option, you can manage your Power over Ethernet options. You also can view the system's real-time total power consumption, output voltage for PoE ports, and the firmware version of the PoE chip.

Port	Enable state	Power Limit Classification	Legacy	Priority	Power Limit (<15400) (mW)	Mode	Current (mA)	Voltage (V)	Power (mW)	Determined Class
5	<input checked="" type="checkbox"/>	<input checked="" type="checkbox"/>	<input type="checkbox"/>	Low	15400	Detecting	0	0.0	0	0.15.4W
6	<input checked="" type="checkbox"/>	<input checked="" type="checkbox"/>	<input type="checkbox"/>	Low	15400	Detecting	0	0.0	0	0.15.4W
7	<input checked="" type="checkbox"/>	<input checked="" type="checkbox"/>	<input type="checkbox"/>	Low	15400	Detecting	0	0.0	0	0.15.4W
8	<input checked="" type="checkbox"/>	<input checked="" type="checkbox"/>	<input type="checkbox"/>	Low	15400	Detecting	0	0.0	0	0.15.4W

---

## Example Configuration: Multiple Ethernet Switch Setup

- Any AXT620 switch (but only one) can be set as the DHCP server
- Each networked device needs an individual connection to the switch
- Connect them via any port

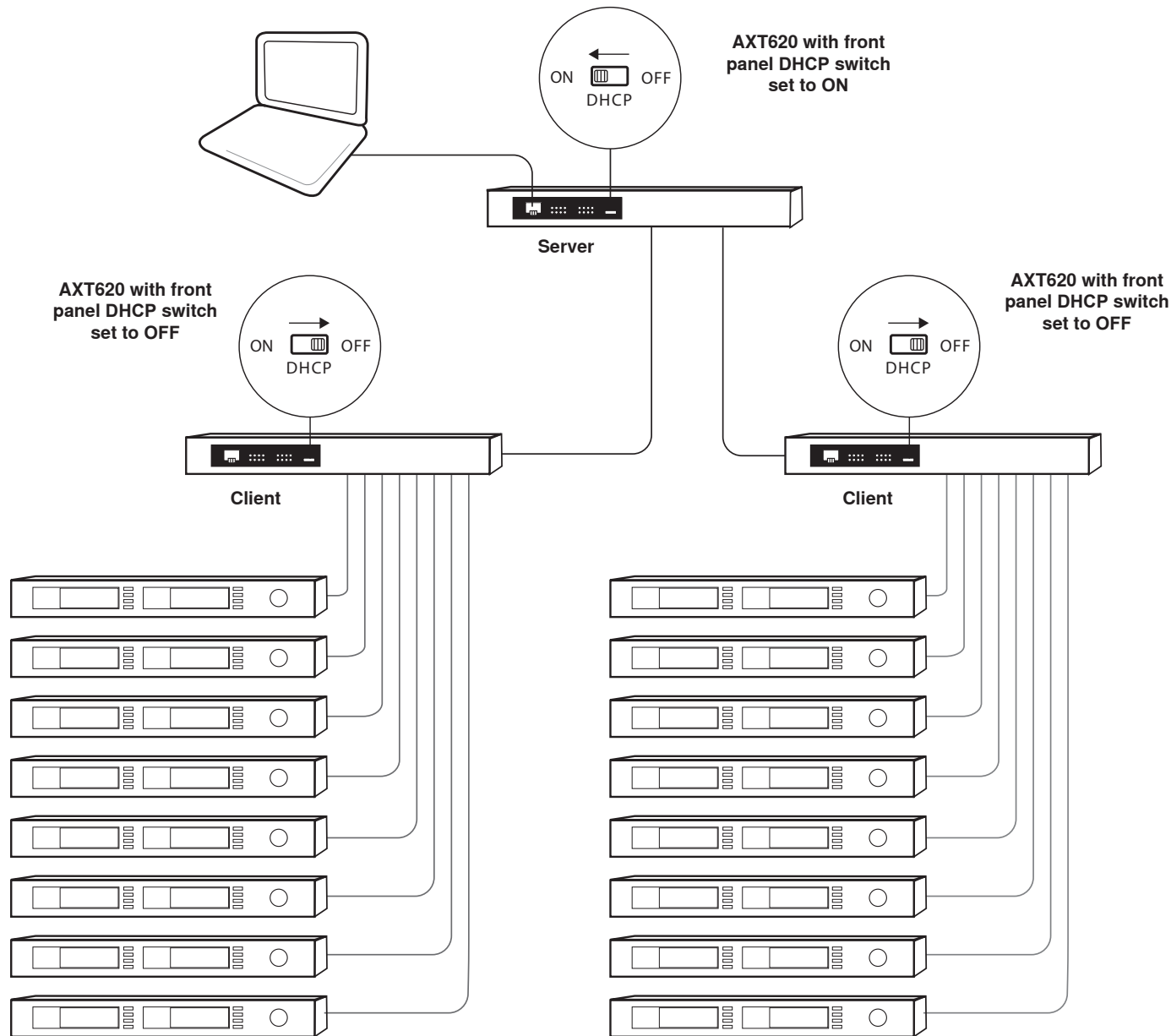

---

## Troubleshooting

### Incorrect connections

The switch port can automatically detect straight or crossover cable when linked with other Ethernet devices. For the RJ-45 connector, STP cable, 10/100Mbps port use 2-pairs twisted cable.

### Faulty or loose cables

Look for loose or faulty connections, and make sure the connections are snug. Lastly, try a different cable.

### Non-standard cables

- Non-standard and incorrectly-wired cables can cause network collisions and other problems, and can impair network performance. A category 5e/6-cable tester is a recommended tool for network installation.
- RJ-45 ports: Use shielded twisted-pair (STP) cable for RJ-45 connections. Be sure that the length of any twisted-pair connection does not exceed 100 meters (328 feet).

### Improper Network Topologies

It is important to make sure that you have a valid network topology. Common topology faults include excessive cable length and too many repeaters (hubs) between end nodes. In addition, you should make sure that your network topology contains no data path loops. Between any two end nodes, there should be only one active cabling path at any time. Data path loops will cause broadcast storms that will severely affect your network performance.

---

## Specifications

Designed to support the following standards:

- IEEE 802.3 10Base-T
- IEEE 802.3u 100Base-TX
- IEEE 802.3x Flow control and Back pressure
- IEEE 802.3ad Port trunk with LACP
- IEEE 802.1d Spanning tree protocol
- IEEE 802.1w Rapid spanning tree
- IEEE 802.1p Class of service
- IEEE 802.1Q VLAN Tagging
- IEEE 802.1x user authentication
- IEEE 802.3af Power Over Ethernet
- IEEE 802.1ab Link Layer Discovery Protocol

### Connector

100Base-T: 9x RJ-45 with auto MDI/MDI-X and PoE inject function

### Power over Ethernet

RJ-45 port 5 - 8 support IEEE 802.3af End-point, Alternative A mode. Provides 15.4 W per port with recoverable over-current protection

### LED

- System Power = Green
- 10/100TX Port (Port 1 to Port 4): Link/Activity (Green), 100Mbps = Amber
- 10/100TX Port (Port 5 to Port 8): Link/Activity = Green, PoE = Amber

### Power Requirements

100 to 240 V AC, 50/60 Hz

### Power Consumption

76.6 Watts (maximum)

### Operating Temperature

-10°C to 60°C, 5% to 95% RH

### Storage Temperature

-40°C to 85°C, 5% to 95% RH

### Dimensions

440 x 44 x 280 mm (17.3 x 1.7 x 11.0 inches)(W x H x D)

### Weight

3.6 kg (8.0 lbs.)

---

## Certifications

Conforms to electrical safety requirements based on IEC 60950-1.

c UL us listed by Underwriters Laboratories, Inc.

Meets essential requirements of the following European Directives and is eligible for CE marking:

- Low Voltage Directive 2006/95/EC & EMC Directive 2004/108/EC
- WEEE Directive 2002/96/EC as amended by 2008/34/EC
- RoHS Directive 2002/95/EC as amended by 2008/35/EC
- This is a networking device and outside the scope of Commission Regulation (EC) No. 1275/2008.

**Note:** Please follow your regional recycling scheme for electronic waste

The CE Declaration of Conformity can be obtained from Shure Incorporated or any of its European representatives. For contact information please visit [www.shure.com](http://www.shure.com)

This device complies with Industry Canada licence-exempt RSS standard(s). Operation of this device is subject to the following two conditions: (1) this device may not cause interference, and (2) this device must accept any interference, including interference that may cause undesired operation of the device.

Le présent appareil est conforme aux CNR d'Industrie Canada applicables aux appareils radio exempts de licence. L'exploitation est autorisée aux deux conditions suivantes : (1) l'appareil ne doit pas produire de brouillage, et (2) l'utilisateur de l'appareil doit accepter tout brouillage radioélectrique subi, même si le brouillage est susceptible d'en compromettre le fonctionnement.

---

## Architect's Specifications

The Ethernet Switch shall be constructed in a 1 RU rack-mountable chassis with an internal power supply. The Ethernet Switch will have 8 RJ-45 ports on the rear panel for connection with professional audio devices and 1 RJ-45 port on the front panel for computer access. All ports shall be 10/100 N-way auto-sensing for 10Base-T or 100Base-TX connections. The Switch shall have a DHCP server function for automatic IP addressing of networked components which can be enabled and disabled using a two-position switch on the front panel. The Switch shall have front panel LED indicators for network status and activity per port. The Switch shall have four ports providing Power over Ethernet for Class 1 Ethernet powered devices. The Switch features can be managed using a web-based interface. The Ethernet Switch shall be the Shure AXT620.



**United States, Canada, Latin  
America, Caribbean:**

Shure Incorporated  
5800 West Touhy Avenue  
Niles, IL 60714-4608 USA

Phone: 847-600-2000  
Fax: 847-600-1212 (USA)  
Fax: 847-600-6446  
Email: [info@shure.com](mailto:info@shure.com)

**Europe, Middle East, Africa:**

Shure Europe GmbH  
Jakob-Dieffenbacher-Str. 12,  
75031 Eppingen, Germany

Phone: 49-7262-92490  
Fax: 49-7262-9249114  
Email: [info@shure.de](mailto:info@shure.de)

**Asia, Pacific:**

Shure Asia Limited  
22/F, 625 King's Road  
North Point, Island East  
Hong Kong

Phone: 852-2893-4290  
Fax: 852-2893-4055  
Email: [info@shure.com.hk](mailto:info@shure.com.hk)